

PART NO. ENMNBD-1-2

**HITACHI**

Reliable solutions

# Operator's Manual

# ZW

# 50-5B

# Wheel Loader

ZW50-5B WHEEL LOADER OPERATOR'S MANUAL

 **Hitachi Construction Machinery Co., Ltd.**

URL:<http://www.hitachi-c-m.com>



Recycle This book is printed on recycled paper.

PRINTED IN JAPAN (E) 2021, 09

ENMNBD-1-2

Serial No. 020001 and up

## INTRODUCTION

**Read this manual** carefully to learn how to operate and service your machine correctly. Failure to do so could result in personal injury or machine damage.

**This standard specification machine** can be operated under the following conditions without being modified.  
Atmospheric Temperature: -20 °C to 40 °C (-4 °F to 104 °F)  
Altitude: 0 m to 1500 m

In case the machine is used under conditions other than described above, consult your nearest Hitachi dealer.

**This manual should be considered** a permanent part of your machine and should remain with the machine when you sell it.

**This machine is of metric** design. Measurements in this manual are metric. Use only metric hardware and tools as specified.

- SI Units (International System of Units) are used in this manual.  
For reference MKS system units and English units are also indicated in parentheses after the SI units.  
Example : 24.5 MPa (250 kgf/cm<sup>2</sup>)

**Right-hand and left-hand** sides are determined by facing in the direction of forward travel.

**Write product identification numbers** in the Machine Numbers section. Accurately record all the numbers to help in tracing the machine should it be stolen. Your dealer also needs these numbers when you order parts. If this manual is kept on the machine, also file the identification numbers in a secure place off the machine.

Use only diesel fuel with quality specified in JIS K-2204, EN-590, ASTM D-975, GOST R52368 or GB252.  
Failure to use diesel fuel with quality as specified above may allow the engine to emit exhaust gas which cleanness can not conform to the requests in various relevant regulations. In addition, serious damage to the engine may result. Consult with your nearest Hitachi dealer for detailed information.

**Warranty** is provided as a part of Hitachi's support program for customers who operate and maintain their equipment as described in this manual. The warranty is explained on the warranty certificate which you should have received from your dealer.

This warranty provides you the assurance that Hitachi will back its products where defects appear within the warranty period. In some circumstances, Hitachi also provides field improvements, often without charge to the customer, even if the product is out of warranty.

**Should the equipment be abused, or modified to change its performance beyond the original factory specifications, the warranty will become void and field improvements may be denied.**

Setting fuel delivery above specifications or otherwise overpowering machines will result in such action.

Only qualified, competent operators should be allowed to operate the machine. Moreover, only officially licensed personnel should be allowed to inspect and service the machine.

The Bluetooth® word mark and logos are registered trademarks owned by Bluetooth SIG, Inc. and any use of such marks by Hitachi Construction Machinery Co., Ltd. is under license. Other trademarks and trade names are those of their respective owners.

All information, illustrations and specifications in this manual are based on the latest product information available at the time of publication. The right is reserved to make changes at any time without notice.

### CALIFORNIA Proposition 65 Warning

**Diesel engine exhaust and some of its constituents are known to the State of California to cause cancer, birth defects, and other reproductive harm.**

# INDEX

MACHINE NUMBERS

SAFETY

SAFETY SIGNS

COMPONENTS NAME

GETTING ON/OFF THE MACHINE

OPERATOR'S STATION

BREAK-IN

OPERATING THE ENGINE

DRIVING THE MACHINE

OPERATING THE MACHINE

TRANSPORTING

MAINTENANCE

MAINTENANCE UNDER SPECIAL ENVIRONMENTAL CONDITIONS

STORAGE

TROUBLESHOOTING

SPECIFICATIONS

OPTIONAL ATTACHMENTS

INDEX



# CONTENTS

<b>MACHINE NUMBERS</b> .....	1	Evacuating in Case of Fire.....	S-32
<b>SAFETY</b> .....	S-1	Beware of Exhaust Fumes.....	S-32
Recognize Safety Information .....	S-1	Precautions for Welding and Grinding .....	S-32
Understand Signal Words.....	S-1	Avoid Heating Near Pressurized Fluid Lines .....	S-33
Follow Safety Instructions.....	S-2	Avoid Applying Heat to Lines Containing Flammable Fluids .....	S-33
Prepare for Emergencies.....	S-3	Precautions for Handling Accumulator and Gas Damper.....	S-33
Wear Protective Clothing.....	S-3	Remove Paint Before Welding or Heating .....	S-34
Protect Against Noise .....	S-4	Beware of Asbestos and Silica Dust and Other Contamination.....	S-34
Inspect Machine .....	S-4	Prevent Battery Explosions .....	S-35
General Precautions for the Cab.....	S-5	Service Air Conditioning System Safely .....	S-35
Use Handrails and Steps .....	S-6	Handle Chemical Products Safely.....	S-36
Never Ride Attachment.....	S-6	Dispose of Waste Properly.....	S-36
Adjust Operator's Seat.....	S-6	<b>SAFETY SIGNS</b> .....	S-37
Ensure Safety Before Rising from or Leaving Operator's Seat .....	S-7	<b>COMPONENTS NAME</b> .....	1-1
Fasten Your Seat Belt.....	S-7	Components Name .....	1-1
Move and Operate Machine Safely.....	S-8	Canopy Vehicle .....	1-1
Handle Starting Aids Safely .....	S-8	Cab Vehicle (Optional).....	1-2
Operate Only from Operator's Seat .....	S-9	<b>GETTING ON/OFF THE MACHINE</b> .....	1-3
Jump Starting .....	S-9	Getting ON/OFF the Machine .....	1-3
Investigate Job Site Beforehand .....	S-10	<b>OPERATOR'S STATION</b> .....	1-4
Equipment of Head Guard, ROPS, FOPS.....	S-11	Features .....	1-4
Provide Signals for Jobs Involving Multiple Machines....	S-11	Front Console.....	1-5
Keep Riders Off Machine .....	S-12	Right Console.....	1-6
Drive Safely .....	S-12	Monitor Panel .....	1-7
Drive Machine Safely (Work Site).....	S-13	Service Indicator (Yellow).....	1-8
Drive Safely with Bucket Loaded .....	S-14	Parking Brake Indicator (Red).....	1-9
Drive on Snow Safely .....	S-14	Brake Level Low Indicator .....	1-9
Travel on Public Roads Safely.....	S-15	Discharge Warning Indicator (Red).....	1-9
Avoid Injury from Rollaway Accidents.....	S-15	Engine Error Alarm (Red) .....	1-9
Avoid Accidents from Backing Up and Turning .....	S-16	Overheat Indicator (Red) .....	1-10
Avoid Positioning Bucket or Attachment Over Anyone.....	S-17	Engine Oil Pressure Indicator (Red) .....	1-10
Avoid Tipping.....	S-17	Air Cleaner Restriction Alarm (Red) .....	1-10
Never Undercut a High Bank.....	S-18	Preheat Indicator (Yellow).....	1-11
Dig with Caution.....	S-18	Seat Belt Indicator (Red) .....	1-11
Perform Truck Loading Safely .....	S-18	Fuel Level Indicator (Orange).....	1-11
Avoid Power Lines.....	S-19	Turn Signal Indicator (Green) .....	1-12
Precautions for Operation.....	S-19	Work Light Indicator (Yellow).....	1-12
Precautions for Lightning.....	S-19	Clearance Light Indicator (Green) .....	1-12
Object Handling .....	S-20	Maintenance Light (Yellow).....	1-13
Protect Against Flying Debris and Falling Object.....	S-21	Monitor Display.....	1-14
Park Machine Safely.....	S-22	F-N-R Indicator .....	1-15
Store Attachments Safely .....	S-22	Travel Mode Indicator (Optional) .....	1-15
Transport Safely .....	S-23	Hour Meter .....	1-16
Handle Fluids Safely—Avoid Fires.....	S-24	Clock.....	1-16
Practice Safe Maintenance.....	S-25	Fuel Gauge .....	1-16
Warn Others of Service Work .....	S-26	Coolant Temperature Gauge .....	1-16
Support Machine Properly.....	S-26	Engine Tachometer .....	1-16
Stay Clear of Moving Parts .....	S-27	Time.....	1-17
Support Maintenance Properly.....	S-27	Maintenance .....	1-18
Prevent Parts from Flying .....	S-28	Checking Hours until Next Maintenance .....	1-18
Prevent Burns.....	S-28	Resetting Hours until Next Maintenance .....	1-19
Replace Rubber Hoses Periodically.....	S-29		
Avoid High-Pressure Fluids .....	S-29		
Prevent Fires.....	S-30		

# CONTENTS

Switches, Steering Wheel and Pedals.....	1-20	Vandal-Resistant Devices.....	1-52
Forward/Reverse Lever.....	1-21	Radio Unit (CAB) (Optional).....	1-53
Neutral Lever Lock (Forward/Reverse Lever).....	1-21	Control Panel.....	1-53
Steering.....	1-22	LCD Display.....	1-54
Horn Switch.....	1-22	Basic Operation.....	1-55
Turn Signal Lever.....	1-22	FM/AM Radio Operation.....	1-59
Light Switch.....	1-23	Control Panel.....	1-59
Hazard Switch (Optional).....	1-24	Bluetooth® Input.....	1-62
Front Work Light Switch (Cab).....	1-25	USB Device Input.....	1-67
Rear Work Light Switch (Cab, Optional).....	1-26	Setting Screens.....	1-70
Parking Brake Switch.....	1-27	<b>BREAK-IN.....</b>	<b>2-1</b>
Front Window Wiper Switch (Cab).....	1-28	Observe Engine Operation Closely.....	2-1
Rear Window Wiper Switch (Cab).....	1-28	<b>OPERATING THE ENGINE.....</b>	<b>3-1</b>
Accelerator Pedal.....	1-29	Check Before Starting.....	3-1
Brake/Inching Pedal.....	1-29	Starting Engine.....	3-3
Right Console.....	1-30	Check After Starting.....	3-5
Loader Control Lever.....	1-31	Using Booster Batteries.....	3-6
Mono-Lever Type.....	1-31	Warm Up Operation.....	3-8
Lever Locks.....	1-32	Warm Up Operation in Cold Weather.....	3-9
Key Switch.....	1-33	Stopping Engine.....	3-10
Travel Mode Switch.....	1-34	<b>DRIVING THE MACHINE.....</b>	<b>4-1</b>
Air Conditioner (Optional) Operation.....	1-35	Driving Machine.....	4-1
Components Name.....	1-35	Starting to Move.....	4-2
Control Panel Arrangement.....	1-35	Parking Brake Switch.....	4-4
Control Panel Switch Designation and Function.....	1-36	Changing Travel Speed.....	4-5
Tips for Optimal Air Conditioner Usage.....	1-37	Changing Forward/Reverse Drive Direction.....	4-5
For Rapid Cooling:.....	1-37	Steering.....	4-6
When Windows Become Clouded:.....	1-37	Stop and Restart of Travel.....	4-7
Maintenance of the Air Conditioner Being Not in Use:.....	1-37	Precautions for Driving on Slopes.....	4-9
Adjusting the Operator's Seat (Reclining Type).....	1-38	Precautions to Be Taken if the Machine Failure Occurs.....	4-10
Name of Components.....	1-38	Stop/Parking.....	4-11
Seat Back Pocket.....	1-39	Emergency Occasions.....	4-13
Fuse Box.....	1-40	<b>OPERATING THE MACHINE.....</b>	<b>5-1</b>
Fuse Box.....	1-41	Loader Control Lever.....	5-1
Fuse Box (Cab-Equipped Machines) (Optional).....	1-41	Lever Locks.....	5-2
Rops Cab (Optional).....	1-42	Adjustment of Bucket Auto Leveler.....	5-3
Room Light.....	1-44	Before Operation.....	5-4
Sun Visor.....	1-44	Precautions for Operation.....	5-4
Drink Holder.....	1-44	Ensure Safety When Operating on Road Shoulders.....	5-4
Emergency Evacuation Hammer.....	1-45	Avoid Overloading.....	5-5
Coat Hook.....	1-45	Avoid Rapid Steering Changes and/or Sudden Braking.....	5-5
Rearview Mirror.....	1-45	Excavation.....	5-6
Rearview Mirror.....	1-45	Digging and Loading Level Ground.....	5-7
Cab Switch Panel (Optional).....	1-46	Grading.....	5-8
Cab Door.....	1-47	Loading.....	5-9
Door Lock Knob.....	1-48	Dozing.....	5-11
Door Open/Close Lever.....	1-48	Scooping.....	5-11
Window Open/Close Levers.....	1-48	Removing Snow.....	5-12
When Fully Opening the Door.....	1-49	Lifting Wheel Loader.....	5-12
Door Lock Disengage Lever.....	1-49	Precautions for After Operation.....	5-13
Articulation Lock Bar.....	1-50	<b>TRANSPORTING.....</b>	<b>6-1</b>
Towing Pin.....	1-50	Transporting by Road.....	6-1
Engine Hood.....	1-51		
Opening/Closing Engine Hood.....	1-51		
Steps.....	1-51		

## CONTENTS

Transporting by Trailer .....	6-1	Clean Radiator, Oil Cooler and Inter Cooler Core .....	7-56
Loading/Unloading on Trailer .....	6-1	H. Electrical System .....	7-57
Transporting .....	6-3	Check Monitor Function and All Other Instrument	
Transporting Wheel Loader		Operation .....	7-57
(Urgent Situation) .....	6-4	Check Work Lights .....	7-58
Towing Method .....	6-9	Check Horn, Backup Alarm and Backup Light .....	7-58
Lifting Machine .....	6-10	Check Electrical Harnesses and Fuses .....	7-59
<b>MAINTENANCE</b> .....	7-1	Fuse Box .....	7-60
Correct Maintenance and Inspection Procedures .....	7-1	Fuse Box (Cab-Equipped Machines) (Optional) .....	7-60
Check the Hour Meter Regularly .....	7-2	Check Electrolyte Level .....	7-65
Use Correct Fuels and Lubricants .....	7-2	Check Electrolyte Specific Gravity .....	7-66
Layout .....	7-3	I. Brake System .....	7-67
Maintenance Guide Table .....	7-4	Check Brake Oil Level .....	7-67
Preparations for Inspection and Maintenance .....	7-5	Check Right and Left Brake Interlocking	
Lock Frames .....	7-6	Performance .....	7-68
Engine Hood .....	7-7	Check Parking Brake Force .....	7-69
Periodic Replacement of Parts .....	7-8	Check Brake Disc (Service and Parking) .....	7-69
Maintenance Guide .....	7-9	Change Brake Oil .....	7-69
Kind of Oils .....	7-15	J. Tire .....	7-70
List of Consumable Parts .....	7-17	Check and Adjust Tire Pressure .....	7-70
A. Greasing .....	7-18	Check Tire for Damage .....	7-71
B. Engine .....	7-22	Check Wheel Bolt Torque .....	7-71
Check Engine Oil Level .....	7-22	Removal and Installation of Tire .....	7-74
Change Engine Oil .....	7-23	Tire Wheel .....	7-74
Replace Engine Oil Filter .....	7-24	K. Air Conditioner .....	7-75
Oil Separator Element (Blow-by Gases) .....	7-25	Check Air Conditioner for Damage .....	7-75
C. Power Train .....	7-26	Check Heater Piping .....	7-75
Change Transmission Oil .....	7-26	Clean and Replace Circulation Air Filter for Air	
Change Axle Oil .....	7-27	Conditioner .....	7-76
Clean Transmission Air Breather .....	7-29	Check Air Conditioner Unit .....	7-77
Check Surrounding Areas Around Axles and Covers		Check Pipelines .....	7-77
for Oil Leaks .....	7-30	Check Air Conditioner Condenser .....	7-78
Clean Axle Housing Air Breather .....	7-30	Check Air Conditioner Drive Belt .....	7-78
D. Hydraulic System .....	7-31	Check Refrigerant Quantity .....	7-79
Inspection and Maintenance of Hydraulic Equipment .....	7-31	Check Compressor and Pulley .....	7-79
Check Hydraulic Oil Level .....	7-32	Check Switch Operation .....	7-79
Change Hydraulic Oil/Clean Hydraulic Oil Tank .....	7-33	L. Miscellaneous .....	7-80
Clean Suction Filter .....	7-35	Check Bucket Bolt-On Cutting Edge for Tightness	
Replace HST Oil Filter Element .....	7-36	and/or Wear .....	7-80
Replace Return Filter .....	7-38	Check and Replace Seat Belt .....	7-81
Check Hoses and Lines .....	7-40	Check Canopy/Cab for Damage and Mounting Bolts	
E. Fuel System .....	7-43	for Tightness .....	7-81
Check Fuel Level .....	7-43	Check Windshield Washer Fluid Level (Cab	
Drain Water and Sediment from Fuel Tank .....	7-44	Equipped Unit) .....	7-81
Drain Water Separator .....	7-45	Check Play in Steering Wheel Stroke .....	7-82
Replace Main Fuel Filter Element .....	7-47	Check Accelerator Pedal Operation, and Exhaust	
Clean the Water Separator .....	7-48	Gas Color and Noise .....	7-83
Check Fuel Hoses .....	7-49	Check Outside and Inside Rearview Mirrors .....	7-84
F. Air Cleaner .....	7-50	Check Steps and Handrails for Damage and	
Clean and Replace Air Cleaner Element .....	7-50	Tightness .....	7-84
G. Cooling System .....	7-51	Clean Engine Compartment and Hood .....	7-84
Check Coolant Level .....	7-53	Check and Adjust Valve Clearance .....	7-85
Check Fan Belt .....	7-54	Check Sound Absorbing Mat Around Engine .....	7-85
Check Fan Belt Tension .....	7-54	Check Fuel Injection Timing .....	7-85
Adjust Fan Belt Tension .....	7-54	Check Engine Compression Pressure .....	7-86
Change Coolant .....	7-55	Check and Clean Starter and Alternator .....	7-86

# CONTENTS

---

---

Retighten Front Axle and Rear Axle Support Mounting Bolts.....	7-86
Tightening and Retightening Torque of Nuts and Bolts .....	7-87
<b>MAINTENANCE UNDER SPECIAL ENVIRONMENTAL CONDITIONS</b> .....	9-1
Maintenance Under Special Environmental Conditions ...	9-1
Precautions for Maintenance During Cold Weather Season.....	9-2
<b>STORAGE</b> .....	10-1
Storing the Machine.....	10-1
Removing the Machine from Storage.....	10-2
<b>TROUBLESHOOTING</b> .....	11-1
<b>SPECIFICATIONS</b> .....	12-1
<b>OPTIONAL ATTACHMENTS</b> .....	13-1
Handling Quick Coupler (Mechanical Type) .....	13-1
<b>INDEX</b> .....	14-1

---



# MACHINE NUMBERS

The manufacturing Nos. explained in this group is the individual number (serial No.) given to each machine and hydraulic components. These numbers are requested when inquiring any information on the machine and/or components. Fill these serial Nos. in the blank spaces in this group to immediately make them available upon request.

## Machine

TYPE: \_\_\_\_\_  
PRODUCT  
IDENTIFICATION  
NUMBER: \_\_\_\_\_

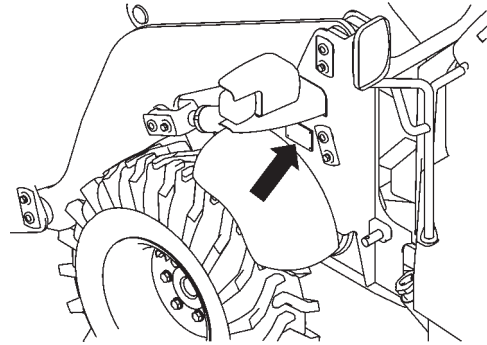

M4EK-00-001

## Product Identification Number

PRODUCT  
IDENTIFICATION  
NUMBER: \_\_\_\_\_



**NOTE:** \_\_\_\_\_  
Marks to indicate  
the start and end  
of the PIN  
\*RYUNBC20C0020001\*  
PRODUCT IDENTIFICATION  
NUMBER (PIN)

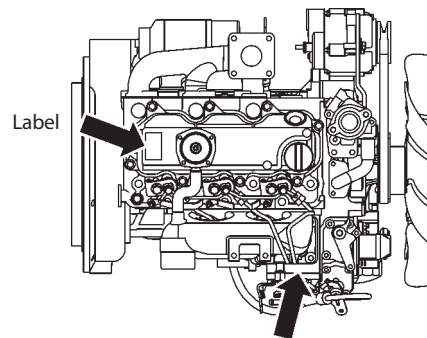

M4EP-00-001

## Engine

TYPE: \_\_\_\_\_  
MFG. NO.: \_\_\_\_\_



## SAFETY

---

### Recognize Safety Information

- These are the **SAFETY ALERT SYMBOLS**.
  - When you see these symbols on your machine or in this manual, be alert to the potential for personal injury.
  - Follow recommended precautions and safe operating practices.

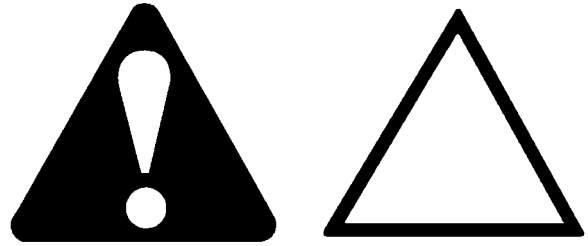

SA-2644

### Understand Signal Words

- On machine safety signs, signal words designating the degree or level of hazard - **DANGER**, **WARNING**, or **CAUTION** - are used with the safety alert symbol.
  - **DANGER** indicates an imminently hazardous situation which, if not avoided, will result in death or serious injury.
  - **WARNING** indicates a potentially hazardous situation which, if not avoided, could result in death or serious injury.
  - **CAUTION** indicates a potentially hazardous situation which, if not avoided, may result in minor or moderate injury.
  - **DANGER or WARNING safety signs** signs are located near specific hazards. General precautions are listed on **CAUTION safety signs**.
  - Some safety signs are occasionally used on this machine that do not use any of the designated signal words mentioned above after the safety alert symbol.
- To avoid confusing machine protection with personal safety messages, a signal word **IMPORTANT** indicates a situation which, if not avoided, could result in damage to the machine.
-  **NOTE** Indicates an additional explanation for a piece of information.



SA-1223

## SAFETY

---

### Follow Safety Instructions

- Carefully read and follow all safety signs on the machine and all safety messages in this manual.
- Safety signs should be installed, maintained and replaced when necessary.
  - If a safety sign or this manual is damaged or missing, order a replacement from your authorized dealer in the same way you order other replacement parts (be sure to state machine model and serial number when ordering).
- Learn how to operate the machine and its controls correctly and safely.
- Allow only trained, qualified, authorized personnel to operate the machine.
- Keep your machine in proper working condition.
  - Unauthorized modifications of the machine may impair its function and/or safety and affect machine life.
  - Do not modify any machine parts without authorization. Failure to do so may deteriorate the safety, function, and/or service life of the part. In addition, personal accident, machine trouble, and/or damage to material caused by unauthorized modifications will void Hitachi Warranty Policy.
  - Do not use attachments and/or optional parts or equipment not authorized by Hitachi. Failure to do so may deteriorate the safety, function, and/or service life of the machine. In addition, personal accident, machine trouble, and/or damage to material caused by using unauthorized attachments and/or optional parts or equipment will void Hitachi Warranty Policy.
- The safety messages in this SAFETY chapter are intended to illustrate basic safety procedures of machines. However it is impossible for these safety messages to cover every hazardous situation you may encounter. If you have any questions, you should first consult your supervisor and/or your authorized dealer before operating or performing maintenance work on the machine.

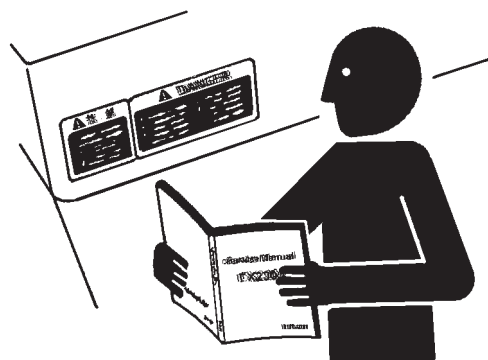

SA-003

## SAFETY

---

### Prepare for Emergencies

- Be prepared for a fire or an accident.
  - Keep a first aid kit and fire extinguisher on hand.
  - Thoroughly read and understand the label attached on the fire extinguisher to use it properly.
  - To ensure that a fire extinguisher can be always used when necessary, check and service the fire extinguisher at the recommended intervals as specified in the fire extinguisher manual.
  - Establish emergency procedure guidelines to cope with fires and accidents.
  - Keep emergency numbers for doctors, ambulance service, hospital, and fire department posted near your telephone.



SA-437

---

### Wear Protective Clothing

- Wear close fitting clothing and safety equipment appropriate to the job.

You may need:

- A hard hat
- Safety shoes
- Safety glasses, goggles, or face shield
- Heavy gloves
- Hearing protection
- Reflective clothing
- Wet weather gear
- Respirator or filter mask.

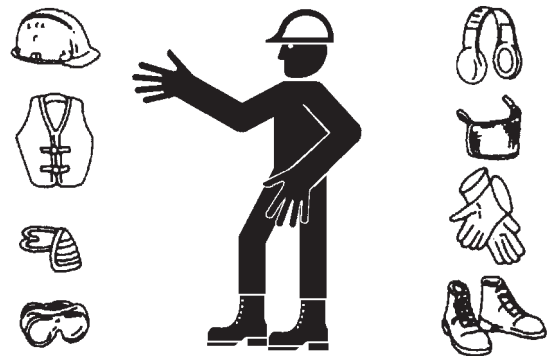

SA-438

Be sure to wear the correct equipment and clothing for the job. Do not take any chances.

- Avoid wearing loose clothing, jewelry, or other items that can catch on control levers or other parts of the machine.
- Operating equipment safely requires the full attention of the operator. Do not wear radio or music headphones while operating the machine.

## SAFETY

---

### Protect Against Noise

- Prolonged exposure to loud noise can cause impairment or loss of hearing.
- Wear a suitable hearing protective device such as earmuffs or earplugs to protect against objectionable or uncomfortably loud noises.



SA-434

---

### Inspect Machine

- Inspect your machine carefully each day or shift by walking around it before you start it to avoid personal injury.
- In the walk-around inspection, be sure to cover all points described in the “Inspect Machine Daily Before Starting” section in the operator’s manual.



SA-435

## SAFETY

---

### General Precautions for the Cab

- Before entering the cab, thoroughly remove all dirt and/or oil such as mud, grease, soil or stones from the soles of your work boots. If any controls such as a pedal is operated while with dirt and/or oil on the soles of the operator's work boots, the operator's foot may slip off the pedal, possibly resulting in a personal accident.
- Do not make a mess around the operator's seat with parts, tools, soil, stones or other, obstacles that may fold up or turn over such as cans or lunch box. The levers or pedals become inoperable if an obstacle jams during the operation stroke of the accelerator pedal, brake pedals, control lever lock switch or control levers, which may result in serious injury or death.
- Avoid storing transparent bottles in the cab. Do not attach any transparent type window decorations on the windowpanes as they may focus sunlight, possibly starting a fire.
- Refrain from listening to the radio, or using music headphones or mobile telephones in the cab while operating the machine.
- Keep all flammable objects and/or explosives away from the machine.
- After using the ashtray, always cover it to extinguish the match and/or tobacco.
- Do not leave cigarette lighters in the cab. When the temperature in the cab increases, the lighter may explode.
- Correctly lay the floor mat specific to the machine. If another floor mat is used, it may be displaced and contact with the accelerator or brake pedals during operation, resulting in serious injury or death.

## SAFETY

---

### Use Handrails and Steps

- Falling is one of the major causes of personal injury.
  - When you get on and off the machine, always face the machine and maintain a three-point contact with the steps and handrails.
  - Do not use any controls as handholds.
  - Never jump on or off the machine. Never mount or dismount a moving machine.
  - Before getting on or off the machine, check the condition of the steps and handrails for sticking of slippery material like grease or mud. Thoroughly remove such material if stuck. In addition, repair the damage to the steps and/or handrails. Retighten loose bolts.
  - Never get on and off the machine with tools in your hands.



SA-439

---

### Never Ride Attachment

- Never allow anyone to ride on attachment or the load. This is an extremely dangerous practice.

---

### Adjust Operator's Seat

- A seat which is poorly adjusted for the individual operator, or the work to be undertaken, may quickly fatigue the operator leading to misoperation.
  - The seat should be adjusted whenever the operator of the machine changes.
  - The operator should be able to fully depress the pedals and to correctly operate the control levers with his back against the seat back.
  - If not, move the seat forward or backward, and check again.
  - Adjust the rear view mirror position so that the best rear visibility is obtained from the operator's seat. If the mirror is broken, immediately replace it with a new one.



SA-462



## SAFETY

---

### Ensure Safety Before Rising from or Leaving Operator's Seat

- Before rising from the operator's seat to open / close either side window or to adjust the seat position, be sure to first lower the front attachment to the ground and then move the control lever lock switch to the lock (🔒) position. Failure to do so may allow the machine to unexpectedly move when a body part unintentionally comes in contact with a control lever, possibly resulting in serious personal injury or death.
- Before leaving the machine, be sure to first lower the front attachment to the ground and then move the control lever lock switch to the lock (🔒) position. Turn the key switch OFF to stop the engine.
- Before leaving the machine, close all windows, doors, and access covers and lock them.

---

### Fasten Your Seat Belt

- If the machine should overturn, the operator may become injured and/or thrown from the cab. Additionally the operator may be crushed by the overturning machine, resulting in serious injury or death.
- Prior to operating the machine, thoroughly examine webbing, buckle and attaching hardware. If any item is damaged or worn, replace the seat belt or component before operating the machine.
- Be sure to remain seated with the seat belt securely fastened at all times when the machine is in operation to minimize the chance of injury from an accident.
- We recommend that the seat belt be replaced every three years regardless of its apparent condition.



SA-237

## SAFETY

---

### Move and Operate Machine Safely

- Bystanders can be run over.
  - Take extra care not to run over bystanders. Confirm the location of bystanders before moving, or operating the machine.
  - Always keep the travel alarm and horn in working condition (if equipped). It warns people when the machine starts to move.
  - Use a signal person when moving, or operating the machine in congested areas. Coordinate hand signals before starting the machine.
  - Use appropriate illumination. Check that all lights are operable before operating the machine. If any faulty illumination is present, immediately repair it.
  - Ensure the cab door, windows, doors and covers are securely locked.
  - Check the mirrors and the monitor in the cab for problems.  
If there is any problem, replace the problem part(s) or clean the mirror, camera and the monitor.  
Refer to Rear View Monitor section for information on cleaning the camera lens and the monitor display.



SA-4EK-001

---

### Handle Starting Aids Safely

Starting fluid:

- Starting fluid is highly flammable.
  - Keep all sparks and flame away when using it.
  - Keep starting fluid well away from batteries and cables.
  - Remove container from machine if engine does not need starting fluid.
  - To prevent accidental discharge when storing a pressurized container, keep the cap on the container, and store it in a cool, well-protected location.
  - Do not incinerate or puncture a starting fluid container.



SA-293

## SAFETY

---

### Operate Only from Operator's Seat

- Inappropriate engine starting procedures may cause the machine to runaway, possibly resulting in serious injury or death.
  - Start the engine only when seated in the operator's seat.
  - Never start the engine while standing on the tire or on ground.
  - Do not start engine by shorting across starter terminals.
  - Before starting the engine, confirm that all control levers are in neutral.
  - Before starting the engine, confirm the safety around the machine and sound the horn to alert bystanders.



SA-4EK-002

---

### Jump Starting

- Battery gas can explode, resulting in serious injury.
  - If the engine must be jump started, be sure to follow the instructions shown in the "OPERATING ENGINE" chapter in the operator's manual.
  - The operator must be in the operator's seat so that the machine will be under control when the engine starts. Jump starting is a two-person operation.
  - Never use a frozen battery.
  - Failure to follow correct jump starting procedures could result in a battery explosion or a runaway machine.



SA-032

## SAFETY

---

### Investigate Job Site Beforehand

- When working at the edge of an excavation or on a road shoulder, the machine could tip over, possibly resulting in serious injury or death.
- Investigate the configuration and ground conditions of the job site beforehand to prevent the machine from falling and to prevent the ground, stockpiles, or banks from collapsing.
- Make a work plan. Use machines appropriate to the work and job site.
- Reinforce ground, edges, and road shoulders as necessary. Keep the machine well back from the edges of excavations and road shoulders.
- When working on an incline or on a road shoulder, employ a signal person as required.
- Confirm that your machine is equipped with a FOPS cab before working in areas where the possibility of falling stones or debris exist.
- When the ground footing is weak, reinforce the ground before starting work.
- When working on frozen ground, be extremely alert. As ambient temperatures rise, the ground footing becomes loose and slippery.
- Beware of the possibility of fire when operating the machine near flammable objects such as dry grass.



SA-4EK-003

## SAFETY

---

### Equipment of Head Guard, ROPS, FOPS

If the machine is operated in areas where the possibility of falling stones or debris, equip a head guard, ROPS, or FOPS according to the potential hazardous conditions. (The standard cab for this machine corresponds to ROPS and FOPS.) Any modification of the ROPS structure will modify its performance and its certification will be lost.

ROPS: Roll-Over Protective Structure

FOPS: Falling Object Protective Structure

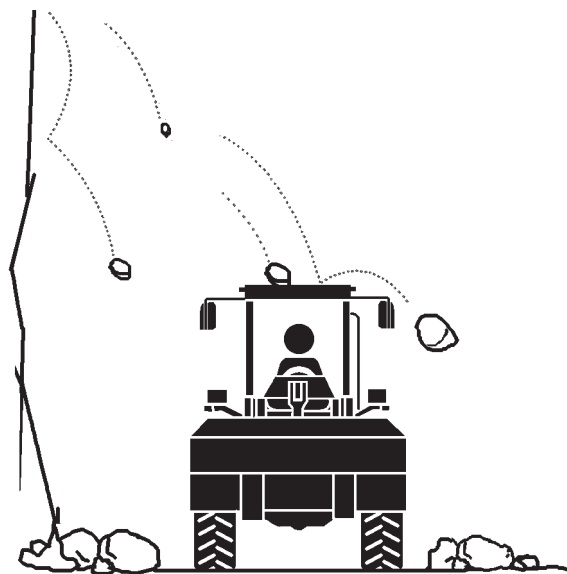

SA-521

---

### Provide Signals for Jobs Involving Multiple Machines

- For jobs involving multiple machines, provide signals commonly known by all personnel involved. Also, appoint a signal person to coordinate the job site. Make sure that all personnel obey the signal person's directions.



SA-481

## SAFETY

---

### Keep Riders Off Machine

- Riders on the machine are subject to injury such as being struck by foreign objects and being thrown off the machine.
- Only the operator should be on the machine. Keep riders off.
- Riders also obstruct the operator's view, resulting in the machine being operated in an unsafe manner.



SA-4EK-004

---

### Drive Safely

- Beware of the possibility of the machine slipping and/or turning over when driving on a slope.
- When driving on level ground, hold the bucket at mark (A) 300 mm above the ground as illustrated.
- Avoid traveling over any obstacles.
- Drive the machine slowly when driving on rough terrain.
- Avoid quick direction changes. Failure to do so may cause the machine to turn over.
- If the engine stops while driving, the steering function becomes inoperative. Immediately stop the machine by applying the brake to prevent personal accident.



SA-4EK-005

## SAFETY

### Drive Machine Safely (Work Site)

- Before driving the machine, always confirm that the steering wheel / and forward / reverse lever (switch) direction corresponds to the direction you wish to drive.
- Be sure to detour around any obstructions.
- Driving on a slope may cause the machine to slip or overturn, possibly resulting in serious injury or death.
  - When driving up or down a slope, keep the bucket facing the direction of travel, approximately 200 to 300 mm (A) above the ground.
  - If the machine starts to skid or becomes unstable, immediately lower the bucket to the ground and stop.
- Driving across the face of a slope or steering on a slope may cause the machine to skid or overturn. If the direction must be changed, move the machine to level ground, then, change the direction to ensure safe operation.

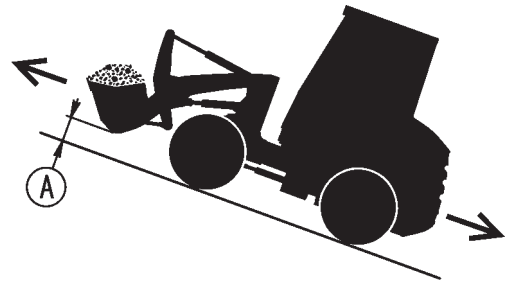

SA-4EK-006

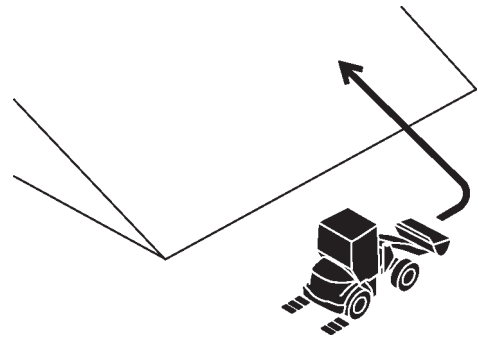

SA-4EK-007

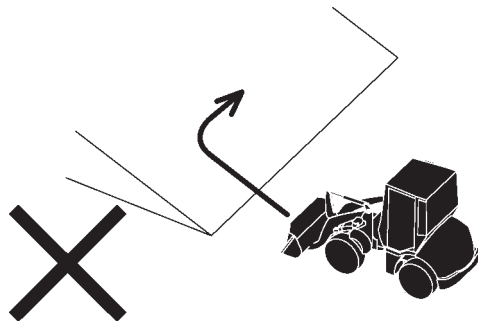

SA-4EK-008

## SAFETY

---

### Drive Safely with Bucket Loaded

- If the machine is incorrectly operated while driving with the bucket loaded, turning over of the machine may result. Be sure to follow all the instructions indicated below.
  - When driving the machine on a job site with the bucket loaded, hold the bucket as low as possible to keep the machine balanced and to have good visibility.
  - Do not exceed the rated load capacity. Always operate the machine within the rated load capacity.
  - Avoid fast starts, stops, and quick turns. Failure to do so may result in personal injury and/or death.
  - Avoid rapid drive direction changes which could possibly cause personal injury and/or death.

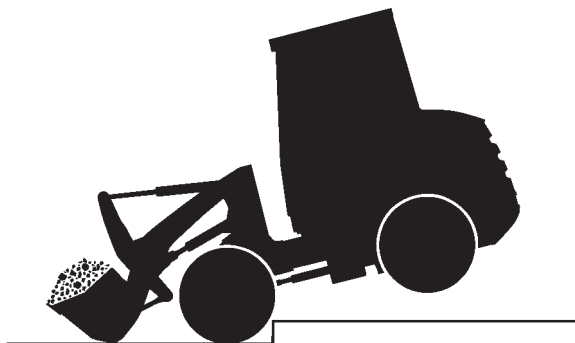

SA-4EK-009

---

### Drive on Snow Safely

- Beware of the possibility of slipping or turning over the machine when driving on frozen snow surfaces.
  - The machine may slip more easily than expected on frozen snow surfaces even if the inclination is small. Reduce speed when driving. Avoid fast starts, stops and quick turns.
  - Road shoulder and/or set-up utilities covered with snow are difficult to locate. Make sure of their location before removing snow.
  - Be sure to use tire chains when driving on snow.
  - Avoid applying the brake for quick stops on snow. If a quick stop is required, lower the bucket to the ground.

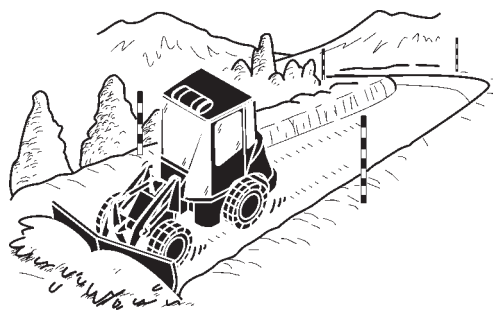

SA-4EK-011



## SAFETY

### Travel on Public Roads Safely

- This machine is not allowed to drive on public roads with the bucket loaded.
- Be sure to empty the bucket.
- Hold the bucket at mark (A) 300 mm above the road surface as illustrated.



SA-4EK-010

### Avoid Injury from Rollaway Accidents

- Death or serious injury may result if you attempt to mount or stop a moving machine.

To avoid rollaways:

- Select level ground when possible to park machine.
- Do not park the machine on a grade.
- Lower the bucket to the ground.
- Put the forward / reverse lever (switch) in neutral, and pull up the parking brake switch (lever) in the ON (parking brake) position.
- Run the engine at low idle speed without load for 5 minutes to cool down the engine.
- Stop the engine and remove the key from the key switch.
- Turn the control lever lock switch to the lock (Ⓐ) position.
- Block both tires and lower the bucket to the ground.
- Position the machine to prevent rolling.
- Park at a reasonable distance from other machines.



SA-4EK-012

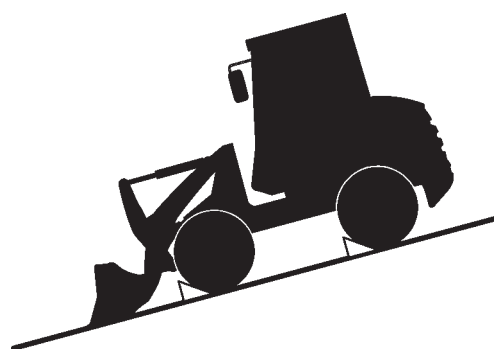

SA-4EK-013

## SAFETY

---

### Avoid Accidents from Backing Up and Turning

- Make sure no one is working under or close to the machine before backing up or turning the machine to avoid personal injury and/or death by being run over or entangled in the machine.
- Keep all personnel away from the machine by sounding the horn and/or using hand signals. Use extra care to be sure no one is in the articulation area before turning the machine.
- Keep windows, mirrors, and lights in good condition.
- Reduce travel speed when dust, heavy rain, fog, etc., reduce the visibility.
- If good visibility is not obtained, use a signal person to guide you.

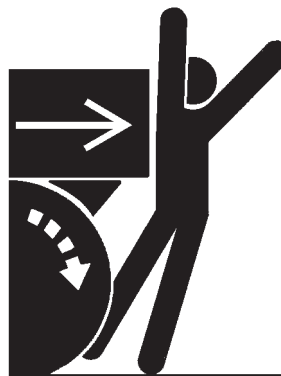

SA-383



SA-312

## SAFETY

---

### Avoid Positioning Bucket or Attachment Over Anyone

- Never allow the bucket or attachment to pass over co-workers and/or the dump truck operator's cab. Falling soil from the bucket or contact with bucket or attachment may cause serious personal accidents and/or damage to the machine.
- Avoid carrying the bucket or attachment over the co-workers to ensure safe operation.



SA-4EK-014

---

### Avoid Tipping

**DO NOT ATTEMPT TO JUMP CLEAR OF A TIPPING MACHINE. MACHINE WILL TIP OVER FASTER THAN YOU CAN JUMP FREE, POSSIBLY RESULTING IN SERIOUS PERSONAL INJURY OR DEATH. IF TIPPING OVER OF THE MACHINE IS EXPECTED, SECURELY HOLD THE STEERING WHEEL TO PREVENT YOUR BODY FROM BEING THROWN OUT OF THE MACHINE.**

**MACHINE WILL TIP OVER FASTER THAN YOU CAN JUMP FREE**

**FASTEN YOUR SEAT BELT**

- The danger of tipping is always present when operating on a grade, possibly resulting in serious injury or death.

To avoid tipping:

- Be extra careful before operating on a gradient.
  - Prepare machine operating area flat.
  - Keep the bucket low to the ground and close to the machine.
  - Reduce operating speeds to avoid tipping or slipping.
  - Avoid changing direction when traveling on gradients.
  - If crossing the gradient is unavoidable, never attempt to travel across a gradient steeper than 5 degrees.
  - Reduce swing speed as necessary when swinging loads.
- Be careful when working on frozen ground.
  - Temperature increases will cause the ground to become soft and make ground travel unstable.

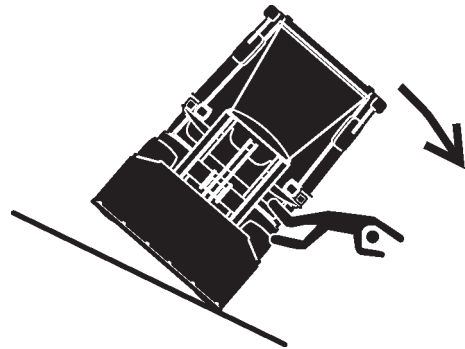

SA-4EK-015

## SAFETY

---

### Never Undercut a High Bank

- The edges could collapse or a land slide could occur causing serious injury or death.



SA-4EK-016

### Dig with Caution

- Accidental severing of underground cables or gas lines may cause an explosion and/or fire, possibly resulting in serious injury or death.
  - Before digging, check the location of cables, gas lines, and water lines.
  - Keep the minimum distance required by law, from cables, gas lines, and water lines.
  - If a fiber optic cable is accidentally severed, do not look into the end. Doing so may result in serious eye injury.
  - Contact your local "diggers hot line" if available in your area, and/or the utility companies directly. Have them mark all underground utilities.



SA-4EK-017

### Perform Truck Loading Safely

- Do not operate the machine involuntarily. Unexpected machine movement may cause personal injury and/or death.
  - Do not lower the bucket with the lift arm control lever in the FLOAT position. The bucket may free fall, possibly causing personal injury and/or death.
  - Always select a level surface for truck loading.

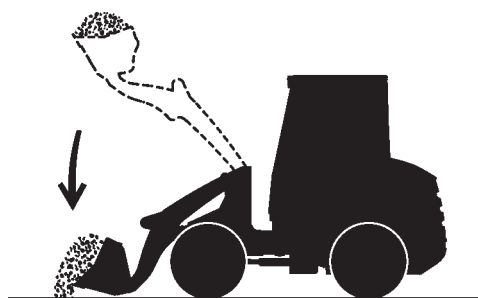

SA-4EK-018

## SAFETY

---

### Avoid Power Lines

Serious injury or death can result from contact with electric lines.

When operating near an electric line, never move any part of the machine or load to within 3 m plus twice the line insulator length of overhead wires.

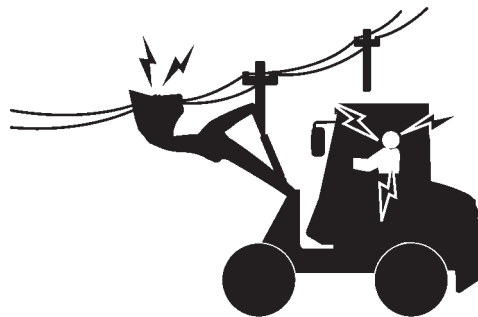

SA-4EK-019

---

### Precautions for Operation

- If the front attachment or any part of the machine comes in contact with an overhead obstacle, both the machine and the overhead obstacle may become damaged, and personal injury may result.
  - Take care to avoid coming in contact with overhead obstacles with the bucket or arm during operation.

---

### Precautions for Lightning

- Lightning may strike the machine.

If lightning comes close, immediately stop the operation, and take the following action.

- When you are around the machine or operating cab-less machine, evacuate to a safe place far away from the machine.
- When you are in the cab, stay in the cab until lightning has passed and safety is secured. Close the cab doors and windows. Lower the bucket to the ground, and stop the engine. Put your hands on your lap to avoid contact with any metal surfaces. Never go out of the cab.

If lightning strikes the machine or near the machine, check all of the machine safety devices for any failure after lightning has passed and safety is secured. If any trouble is found, operate the machine only after repairing it.



SA-4EK-020

## SAFETY

---

### Object Handling

#### **CRANING OPERATION USING THE MACHINE IS NOT ALLOWED.**

- If a lifted load should fall, any person nearby may be struck by the falling load or may be crushed underneath it, resulting in serious injury or death.

Never attach a sling or chain to the bucket teeth or to the attachment (fork or grapple for example). They may come off, causing the load to fall.



SA-132

## SAFETY

---

### Protect Against Flying Debris and Falling Object

- During hammer operation, debris from earth, rock or metal may fly in all directions, resulting in a serious personal injury or death.
  - When driving the connecting pins in or out, wear goggles or safety glasses, hard hat and face shield.

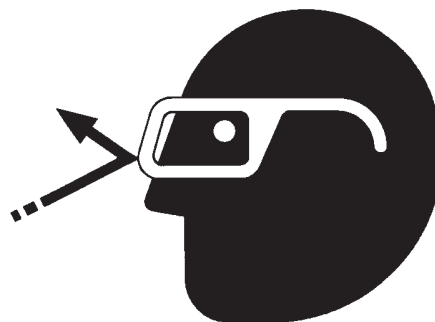

SA-432

- During machine operation, debris from earth, rock or metal may fly off from the tire and bucket, resulting in a serious personal injury or death.
  - Ensure nobody presents in or around the work area while machine is operating.



SA-344

- Falling of accumulated earth or dirt onto people may result in a serious personal injury or death.
  - Before performing maintenance, remove accumulated debris.



SA-527

## SAFETY

---

### Park Machine Safely

To avoid accidents:

- Park the machine on a firm, level surface.
- Lower bucket to the ground.
- Put the forward / reverse lever (switch) in neutral, and turn the parking brake switch (lever) ON (parking brake) position.
- Run the engine at low idle speed without load for 5 minutes.
- Turn key switch to OFF to stop engine.
- Remove the key from the key switch.
- Turn the control lever lock switch to the lock (🔒) position.
- Close windows, roof vent, and cab door.
- Lock all access doors and compartments.

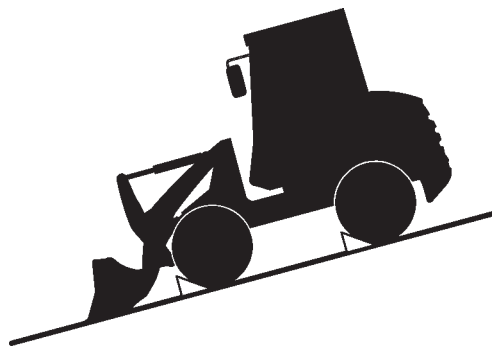

SA-4EK-013

---

### Store Attachments Safely

- Stored attachments such as buckets, hydraulic hammers, and blades can fall and cause serious injury or death.
- Securely store attachments and implements to prevent falling. Keep children and bystanders away from storage areas.

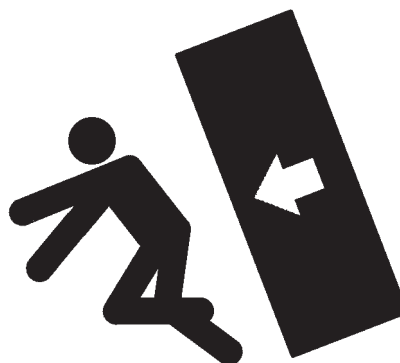

SA-034



## SAFETY

---

### Transport Safely

- Be aware care that the machine may turn over when loading or unloading the machine onto or off of a truck or trailer.
  - Observe the related regulations and rules for safe transportation.
  - Select an appropriate truck or trailer for the machine to be transported.
  - Be sure to use a signal person.
  - Always follow the following precautions for loading or unloading:
    1. Select solid and level ground.
    2. Always use a ramp or deck strong enough to support the machine weight.
    3. Use the low speed gear.
    4. Never steer the machine while on the ramp. If the traveling direction must be changed while on the ramp, unload the machine from the ramp, reposition the machine on the ground, then try loading again.
    5. After loading, install the lock bar to securely hold the articulation mechanism.
    6. Wedge the front and rear of tires. Securely hold the machine to the truck or trailer deck with wire ropes.

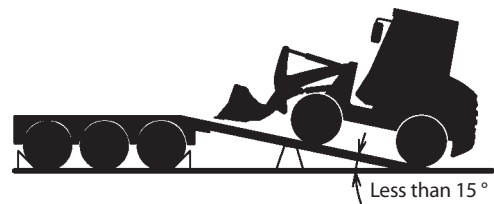

SA-4EK-021

Be sure to further follow the details described in the TRANSPORTING chapter.

## SAFETY

---

### Handle Fluids Safely—Avoid Fires

- Handle fuel with care; it is highly flammable. If fuel ignites, an explosion and/or a fire may occur, possibly resulting in serious injury or death.
  - Do not refuel the machine while smoking or when near open flame or sparks.
  - Always stop the engine before refueling the machine.
  - Fill the fuel tank outdoors.
- All fuels, most lubricants, and some coolants are flammable.
  - Store flammable fluids well away from fire hazards.
  - Do not incinerate or puncture pressurized containers.
  - Do not store oily rags; they can ignite and burn spontaneously.
  - Securely tighten the fuel and oil filler caps.



SA-018



SA-019

## SAFETY

### Practice Safe Maintenance

To avoid accidents:

- Understand service procedures before starting work.
- Keep the work area clean and dry.
- Do not spray water or steam inside cab.
- Never lubricate or service the machine while it is moving.
- Keep hands, feet and clothing away from power-driven parts.

Before servicing the machine:

1. Park the machine on a level surface.
2. Lower the bucket to the ground.
3. Run the engine at low idle speed without load for 5 minutes.
4. Turn the key switch to OFF to stop engine.
5. Relieve the pressure in the hydraulic system by moving the control levers several times.
6. Remove the key from the key switch.
7. Attach a "Do Not Operate" tag on the control lever.
8. Turn the control lever lock switch to the lock (🔒) position.
9. Lock bar connects the front and rear frames.
10. Allow the engine to cool.

- If a maintenance procedure must be performed with the engine running, do not leave machine unattended.
- Never work under a machine raised by the lift arm.
- Inspect certain parts periodically and repair or replace as necessary. Refer to the section discussing that part in the "MAINTENANCE" chapter of this manual.
- Keep all parts in good condition and properly installed.
- Fix damage immediately. Replace worn or broken parts. Remove any buildup of grease, oil, or debris.
- When cleaning parts, always use nonflammable detergent oil. Never use highly flammable oil such as fuel oil and gasoline to clean parts or surfaces.
- Disconnect battery ground cable (-) before making adjustments to electrical systems or before performing welding on the machine.



SA-028



SA-312



SA-134



SA-527

## SAFETY

---

- Sufficiently illuminate the work site. Use a maintenance work light when working under or inside the machine.
- Always use a work light protected with a guard. If the light bulb is broken, spilled fuel, oil, antifreeze fluid, or window washer fluid may catch fire.



SA-037

---

### Warn Others of Service Work

- Unexpected machine movement can cause serious injury.
  - Before performing any work on the machine, attach a “Do Not Operate” tag on the control lever. This tag is available from your authorized dealer.

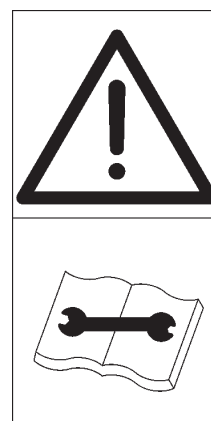

SS2045102-4

---

### Support Machine Properly

- Never attempt to work on the machine without securing the machine first.
  - Always lower the attachment to the ground before you work on the machine.
  - If you must work on a lifted machine or attachment, securely support the machine or attachment. Do not support the machine on cinder blocks, hollow tires, or props that may crumble under continuous load. Do not work under a machine that is supported solely by a jack.



SA-527

## SAFETY

---

### Stay Clear of Moving Parts

- Entanglement in moving parts can cause serious injury.
- To prevent accidents, care should be taken to ensure that hands, feet, clothing, jewelry and hair do not become entangled when working around rotating parts.

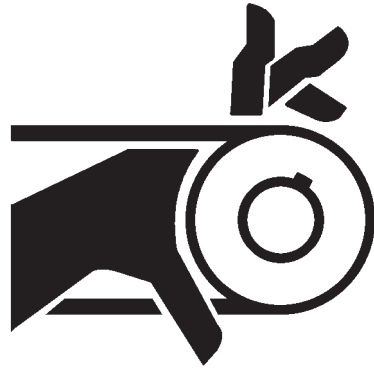

SA-026

### Support Maintenance Properly

- Explosive separation of a tire and rim parts can cause serious injury or death.
- Do not attempt to mount a tire unless you have the proper equipment and experience to perform the job. Have it done by your authorized dealer or a qualified repair service.
- Always maintain the correct tire pressure. DO NOT inflate tire above the recommended pressure.
- When inflating tires, use a chip-on chuck and extension hose long enough to allow you to stand to one side and not in front of or over the tire assembly. Use a safety cage if available.
- Inspect tires and wheels daily. Do not operate with low pressure, cuts bubbles, damaged rims, or missing lug bolts and nuts.
- Never cut or weld on an inflated tire or rim assembly. Heat from welding could cause an increase in pressure and may result in tire explosion.

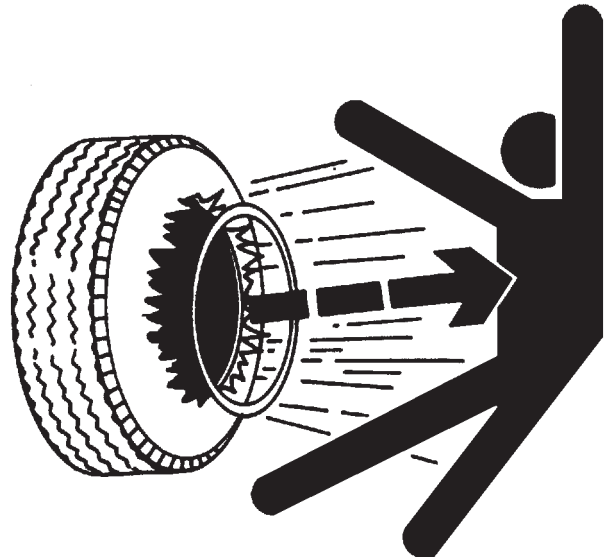

SA-249

## SAFETY

---

### Prevent Parts from Flying

- Travel reduction gears are under pressure.
  - As pieces may fly off, be sure to keep body and face away from AIR RELEASE PLUG to avoid injury.
  - GEAR OIL is hot. Wait for GEAR OIL to cool, then gradually loosen AIR RELEASE PLUG to release pressure.



SA-344

### Prevent Burns

Hot spraying fluids:

- After operation, engine coolant is hot and under pressure. Hot water or steam is contained in the engine, radiator and heater lines. Skin contact with escaping hot water or steam can cause severe burns.
  - Avoid possible injury from hot spraying water. DO NOT remove the radiator cap until the engine is cool. When opening, turn the cap slowly to the stop. Allow all pressure to be released before removing the cap.
  - The hydraulic oil tank is pressurized. Again, be sure to release all pressure before removing the cap.



SA-039

Hot fluids and surfaces:

- Engine oil, gear oil and hydraulic oil also become hot during operation. The engine, hoses, lines and other parts become hot as well.
  - Wait for the oil and components to cool before starting any maintenance or inspection work.



SA-225

## SAFETY

### Replace Rubber Hoses Periodically

- Rubber hoses that contain flammable fluids under pressure may break due to aging, fatigue, and abrasion. It is very difficult to gauge the extent of deterioration due to aging, fatigue, and abrasion of rubber hoses by inspection alone.
- Periodically replace the rubber hoses. (See the page of "Periodic replacement of parts" in the operator's manual.)
- Failure to periodically replace rubber hoses may cause a fire, fluid injection into skin, or the front attachment to fall on a person nearby, which may result in severe burns, gangrene, or otherwise serious injury or death.



SA-019

### Avoid High-Pressure Fluids

- Fluids such as diesel fuel or hydraulic oil under pressure can penetrate the skin or eyes causing serious injury, blindness or death.
- Avoid this hazard by relieving pressure before disconnecting hydraulic or other lines.
- Tighten all connections before applying pressure.
- Search for leaks with a piece of cardboard; take care to protect hands and body from high-pressure fluids. Wear a face shield or goggles for eye protection.
- If an accident occurs, see a doctor familiar with this type of injury immediately. Any fluid injected into the skin must be surgically removed within a few hours, or gangrene may result.



SA-031



SA-292

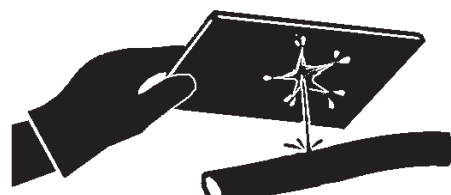

SA-044

## SAFETY

---

### Prevent Fires

Check for Oil Leaks:

- Fuel, hydraulic oil and lubricant leaks can lead to fires.
  - Check for oil leaks due to missing or loose clamps, kinked hoses, lines or hoses that rub against each other, damage to the oil-cooler, and loose oil-cooler flange bolts.
  - Tighten, repair or replace any missing, loose or damaged clamps, lines, hoses, oil-cooler and oil-cooler flange bolts.
  - Do not bend or strike high-pressure lines.
  - Never install bent or damaged lines, pipes, or hoses.
  - Replace fuel hoses and hydraulic hoses periodically even if there is no abnormality in their external appearance.



SA-019

Check for Shorts:

- Short circuits can cause fires.
  - Clean and tighten all electrical connections.
  - Check before each shift or after eight (8) to ten (10) hours operation for loose, kinked, hardened or frayed electrical cables and wires.
  - Check before each shift or after eight (8) to ten (10) hours operation for missing or damaged terminal caps.
  - DO NOT OPERATE MACHINE if cable or wires are loose, kinked, etc.
  - Never attempt to modify electric wiring.



## SAFETY

---

### Clean up Flammable Materials:

- Spilled fuel and oil, and trash, grease, debris, accumulated coal dust, and other flammable materials may cause fires.
  - Prevent fires by inspecting and cleaning the machine daily, and by removing adhered oil or accumulated flammable materials immediately. Check and clean high temperature parts such as the exhaust outlet and mufflers earlier than the normal interval.
  - Do not wrap high temperature parts such as a muffler or exhaust pipe with oil absorbents.
  - Do not store oily cloths as they are vulnerable to catching fire.
  - Keep flammable materials away from open flames.
  - Do not ignite or crush a pressurized or sealed container.
  - Wire screens may be provided on openings on the engine compartment covers to prevent flammable materials such as dead leaves from entering. However, flammable materials which have passed through the wire screen may cause fires. Check and clean the machine every day and immediately remove accumulated flammable materials.

### Check Key Switch:

- If a fire breaks out, failure to stop the engine will escalate the fire, hampering fire fighting.  
Always check key switch function before operating the machine every day:
  1. Start the engine and run it at low idle.
  2. Turn the key switch to the OFF position to confirm that the engine stops.
- If any abnormalities are found, be sure to repair them before operating the machine.

### Check Heat Shields:

- Damaged or missing heat shields may lead to fires.
  - Damaged or missing heat shields must be repaired or replaced before operating the machine.
  - If hydraulic hoses are broken while the engine cover is open, splattered oil on the high temperature parts such as mufflers may cause fire. Always close the engine cover while operating the machine.

## SAFETY

### Evacuating in Case of Fire

- If a fire breaks out, evacuate the machine in the following way:
  - Stop the engine by turning the key switch to the OFF position if there is time.
  - Use a fire extinguisher if there is time.
  - Exit the machine.
- In an emergency, if the cab door can not be opened, break the front or rear window panes with the emergency evacuation hammer to escape from the cab. Refer to the explanation pages on the Emergency Evacuation Method.



SA-393



SS-1510

### Beware of Exhaust Fumes

- Prevent asphyxiation. Engine exhaust fumes can cause sickness or death.
- If you must operate in a building, be sure there is adequate ventilation. Either use an exhaust pipe extension to remove the exhaust fumes or open doors and windows to bring enough outside air into the area.

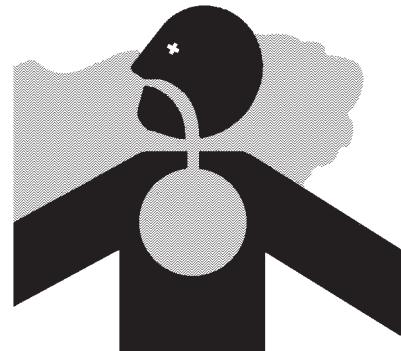

SA-016

### Precautions for Welding and Grinding

- Welding may generate gas and/or small fires.
  - Be sure to perform welding in a well ventilated and prepared area. Store flammable objects in a safe place before starting welding.
  - Only qualified personnel should perform welding. Never allow an unqualified person to perform welding.
- Grinding on the machine may create fire hazards. Store flammable objects in a safe place before starting grinding.
- After finishing welding and grinding, recheck that there are no abnormalities such as the area surrounding the welded area still smoldering.



SA-818

## SAFETY

---

### Avoid Heating Near Pressurized Fluid Lines

- Flammable spray can be generated by heating near pressurized fluid lines, resulting in severe burns to yourself and bystanders.
- Do not heat by welding, soldering, or using a torch near pressurized fluid lines or other flammable materials.
- Pressurized lines can be accidentally cut when heat goes beyond the immediate flame area. Install temporary fire-resistant guards to protect hoses or other materials before engaging in welding, soldering, etc..



SA-030

---

### Avoid Applying Heat to Lines Containing Flammable Fluids

- Do not weld or flame cut pipes or tubes that contain flammable fluids.
- Clean pipes and tubes thoroughly with non-flammable solvent before welding or flame cutting.

---

### Precautions for Handling Accumulator and Gas Damper

High-pressure nitrogen gas is sealed in the accumulator and the gas damper. Inappropriate handling may cause explosion, possibly resulting in serious injury or death.

Strictly comply with the following items:

- Do not disassemble the unit.
- Keep the units away from open flames and fire.
- Do not bore a hole, do not cut by torch.
- Avoid giving shocks by hitting or rolling the unit.
- Before disposing of the unit, sealed gas must be released. Consult your nearest authorized dealer.

## SAFETY

---

### Remove Paint Before Welding or Heating

- Hazardous fumes can be generated when paint is heated by welding, soldering, or using a torch. If inhaled, these fumes may cause sickness.
    - Avoid potentially toxic fumes and dust.
    - Do all such work outside or in a well-ventilated area. Dispose of paint and solvent properly.
    - Remove paint before welding or heating:
1. If you sand or grind paint, avoid breathing the dust. Wear an approved respirator.
  2. If you use solvent or paint stripper, remove stripper with soap and water before welding. Remove solvent or paint stripper containers and other flammable material from area. Allow fumes to disperse at least 15 minutes before welding or heating.



SA-029

---

### Beware of Asbestos and Silica Dust and Other Contamination

- Take care not to inhale dust produced in the work site. Inhalation of asbestos fibers may be the cause of lung cancer. Inhalation of silica dust and other contamination may cause sickness.
  - Depending on the work site conditions, the risk of inhaling asbestos fiber, silica dust or other contamination may exist. Spray water to prevent asbestos fibers, silica dust or other contamination from becoming airborne. Do not use compressed air.
  - When operating the machine in a work site where asbestos fibers, silica dust or other contaminations might be present, be sure to operate the machine upwind, and wear a mask rated to prevent the inhalation of asbestos, silica dust or other contaminations.
  - Keep bystanders out of the work site during operation.
  - Asbestos might be present in non-genuine parts. Use only genuine Hitachi Parts.



SA-029

## SAFETY

---

### Prevent Battery Explosions

- Battery gas can explode.
  - Keep sparks, lighted matches, and flame away from the top of battery.
  - Never check battery charge by placing a metal object across the posts. Use a voltmeter or hydrometer.
  - Do not charge a frozen battery; it may explode. Warm the battery to 16 °C (60 °F) first.
  - Do not continue to use or charge the battery when electrolyte level is lower than specified. Explosion of the battery may result.
  - Loose terminals may produce sparks. Securely tighten all terminals.
  - Connect terminals to the correct electrical poles. Failure to do so may cause damage to the electrical parts or fire.
- Battery electrolyte is poisonous. If the battery should explode, battery electrolyte may be splashed into eyes, possibly resulting in blindness.
  - Be sure to wear eye protection when checking electrolyte specific gravity.



SA-032

---

### Service Air Conditioning System Safely

- If spilled onto skin, refrigerant may cause a cold contact burn.
  - Refer to the instructions described on the container for proper use when handling the refrigerant.
  - Use a recovery and recycling system to avoid leaking refrigerant into the atmosphere.
  - Never touch the refrigerant.



SA-405

## SAFETY

---

### Handle Chemical Products Safely

- Direct exposure to hazardous chemicals can cause serious injury. Potentially hazardous chemicals used with your machine include such items as lubricants, coolants, paints, and adhesives.
- A Safety Data Sheet (SDS) provides specific details on chemical products: physical and health hazards, safety procedures, and emergency response techniques.
- Check the SDS before you start any job using a hazardous chemical. That way you will know exactly what the risks are and how to do the job safely. Then follow procedures and use recommended equipment.
- See your authorized dealer for SDS's (available only in English) on chemical products used with your machine.



SA-2579

---

### Dispose of Waste Properly

- Improperly disposing of waste can threaten the environment and ecology. Potentially harmful waste used with Hitachi equipment includes such items as oil, fuel, coolant, brake fluid, filters, and batteries.
- Use leakproof containers when draining fluids. Do not use food or beverage containers that may mislead someone into drinking from them.
- Do not pour waste onto the ground, down a drain, or into any water source.
- Air conditioning refrigerants escaping into the air can damage the Earth's atmosphere. Government regulations may require a certified air conditioning service center to recover and recycle used air conditioning refrigerants.
- Inquire on the proper way to recycle or dispose of waste from your local environmental or recycling center, or from your authorized dealer.

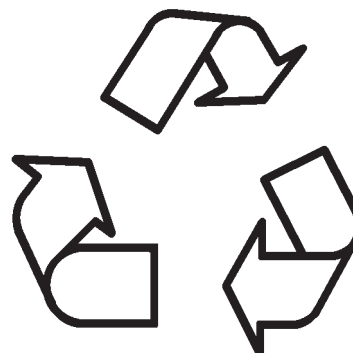

SA-226

## SAFETY SIGNS

All safety signs and their locations affixed on the machine are illustrated in this group. Make sure of the contents described in the safety signs through reading actual ones affixed on the machine to ensure safe machine operation. Always keep the safety signs clean. In case a safety sign is broken or lost, immediately obtain a new replacement and affix it again in position on the machine. Use the part No. indicated under the right corner of each safety sign illustration when placing an order for it to the authorized dealer.

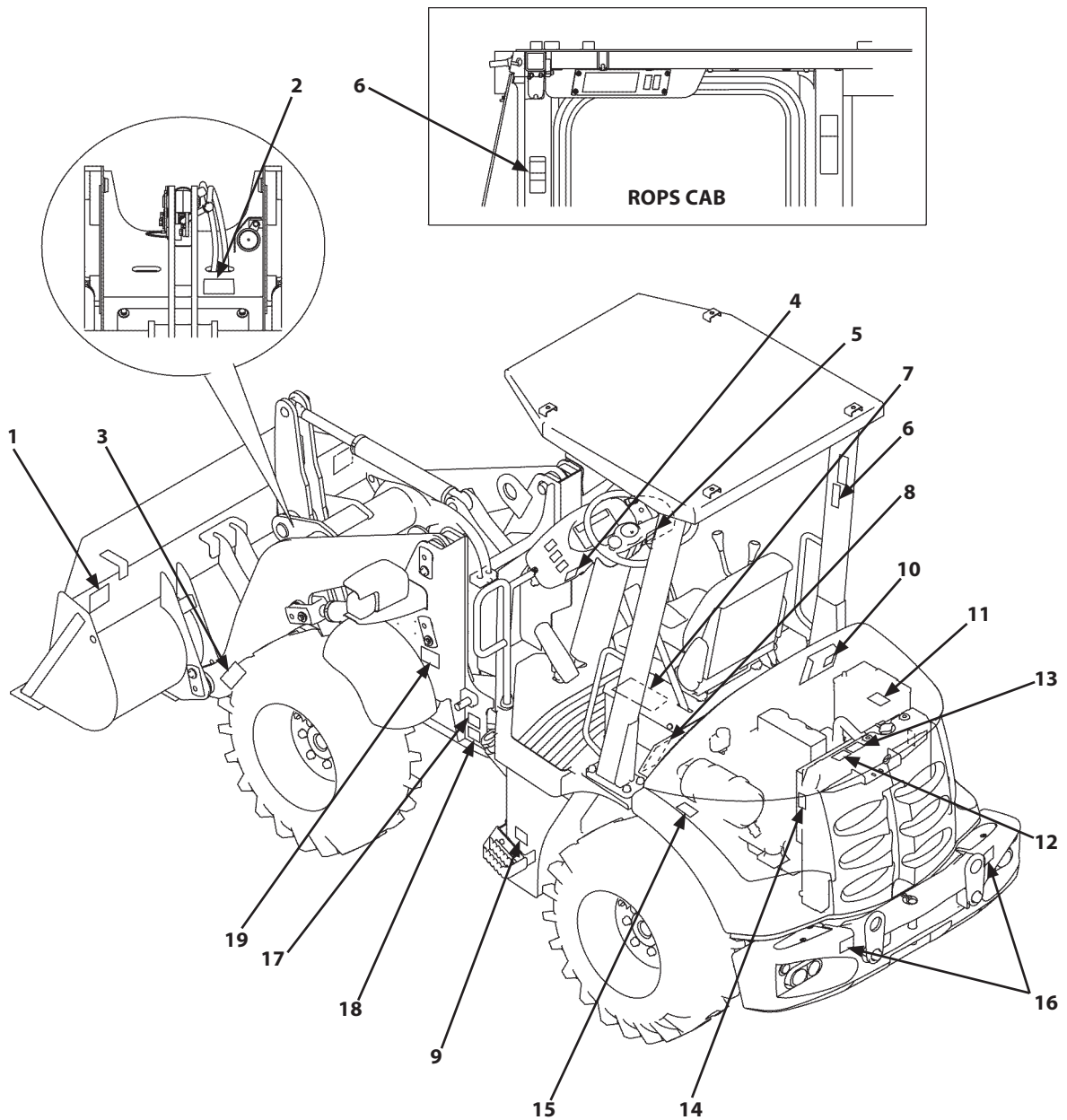

SS-E804-001\_E

## SAFETY SIGNS

### 1. Both sides of bucket

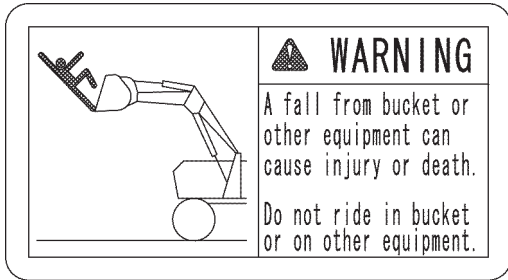

SS-4EK-017\_E

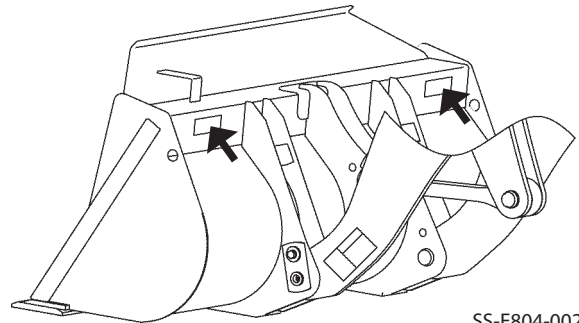

SS-E804-002\_E

- Sign indicates a hazard of falling.
- Do not stand on this place.

### 2. Front Maintenance Access Cover for Front Frame



SS-4EK-019\_E

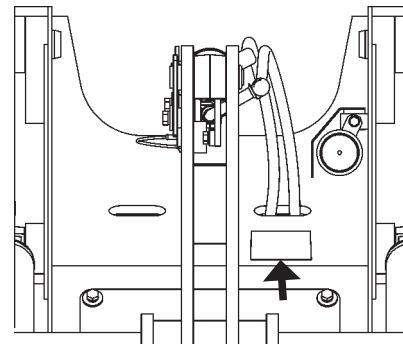

SS-4EK-004\_E

- The front attachment may automatically be lowered, possibly resulting in personal injury. Lower the front attachment to the ground before inspecting/maintaining the machine. In case inspection and/or maintenance work must unavoidably be performed with the front attachment raised, lock the front attachment control levers in position. Then, securely support the front attachment with safety supports and/or blocks.

### 3. Both sides of Lift Arm

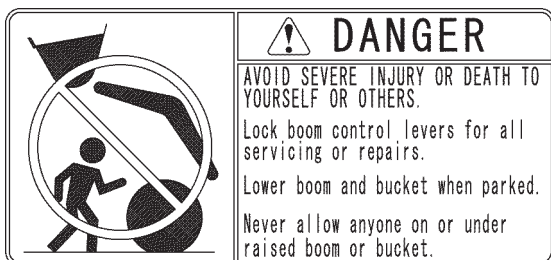

SS-4EK-020\_E

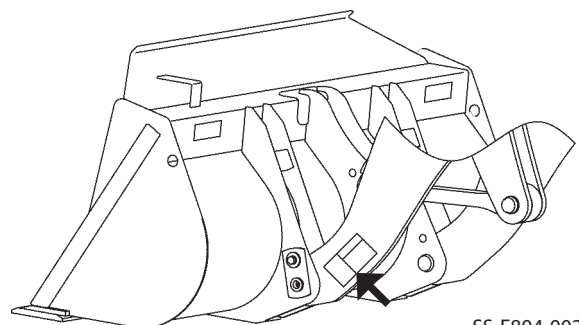

SS-E804-002\_E



## SAFETY SIGNS

### 4. Left Side of Front Console

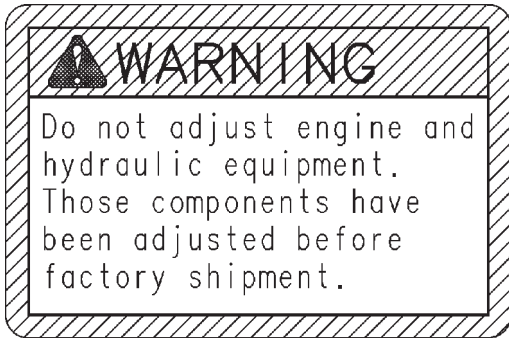

SS-4169

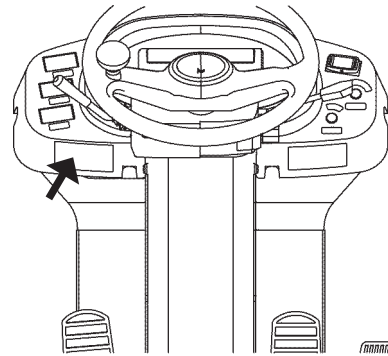

SS-4EK-005 E

### 5. Right Side of Front Console

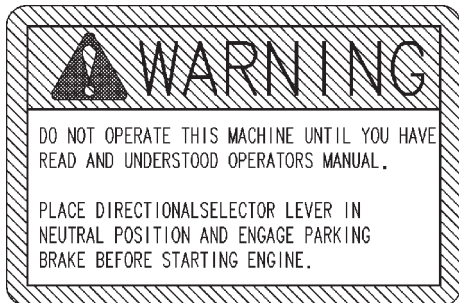

SS-4170

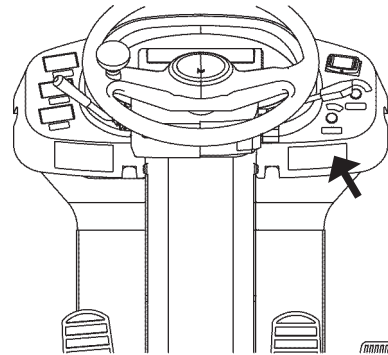

SS-4EK-005 E

### 6. ROPS Canopy Right Rear Column Cab Inside Right Front Column (Option)

- WARNING:**  
 To minimize the injury due to an overturning accident, be sure to fasten the seat belt prior to operating the machine.

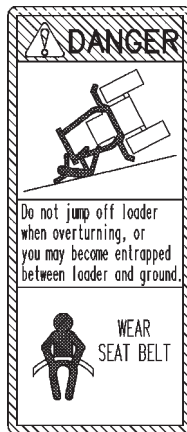

SS-4171

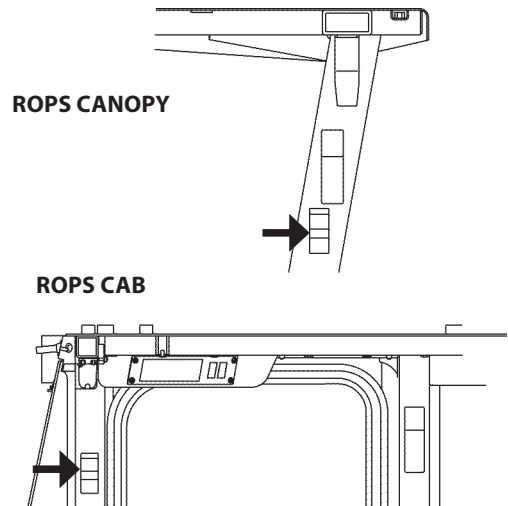

SS-E804-003\_E

## SAFETY SIGNS

### 7. Steering Cover

**⚠ WARNING**

**YOU MUST FOLLOW THESE RULES TO AVOID SEVERE INJURY OR DEATH TO YOURSELF AND OTHERS.**

- Operate loader only if trained and authorized by your employer. Know Operation & Maintenance Manual and all work rules.
- Safety check loader every day. Do not start if damaged or faulty ; stop if problems start. Make sure ROPS and seatbelt are in place and used.
- Repair allowed only by trained, authorized mechanics. Use safety link, and parking brake for all repairs.
- Stay in seat when operating, keep hands and feet in cab. Use goggles, hard hat and work shoes.
- Turn, start, stop and handle boom smoothly and slowly. Carry boom low and bucket tilted back. Do not pick up unbalanced or over-capacity loads.
- Look where you are going. Watch for people, drop-offs, holes, and electrical wires. Check clearances all around, including rear, overhead, and boom swing.
- Do not carry passengers in or on the loader. Do not raise people with boom or bucket.
- Keep heavy end uphill on all inclines ; travel straight up or down, do not cross on an angle. Use low gear up and down inclines.
- Loader roll over can kill you. Slow for all turns and hazards even if unloaded. Stay clear of edges. Use seatbelt and ROPS. Stay with loader if it overturns.
- Avoid fires. Keep loader clean and remove all oil, grease, grass or other material from the engine or exhaust area. Repair all leaks immediately.
- Stop engine when refueling. Follow Operation & Maintenance Manual and employer's work rules about fuel, battery, tire maintenance hazards.
- Park only in authorized areas, never on inclines. Lower boom and bucket, put direction control in neutral, turn off key, set parking brake, block wheels, set safety link.

SS-4EK-026\_E

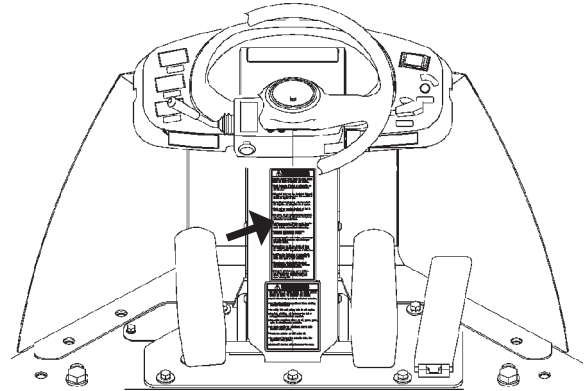

SS-4172

### 8. Steering Cover

**⚠ WARNING**

**YOU MUST FOLLOW THESE RULES TO AVOID SEVERE INJURY OR DEATH TO YOURSELF AND OTHERS.**

- Repair allowed only by trained, authorized mechanics.
- Know Operation & Maintenance Manual before starting repairs or maintenance.
- Use safety link, and parking brake for all repairs.
- Keep body, clothing, and tools away from hot or moving parts and electrical components.
- Keep engine compartment clean ; no oil, grease, grass, paper, or other flammable materials.
- Run engine only in well ventilated area to avoid poisonous exhaust gasses.
- Do not open radiator cap with engine hot.
- Use cardboard to check for hydraulic leaks. Wear goggles and heavy gloves.
- Replace all steering system hoses every two years.

SS-4EK-024\_E

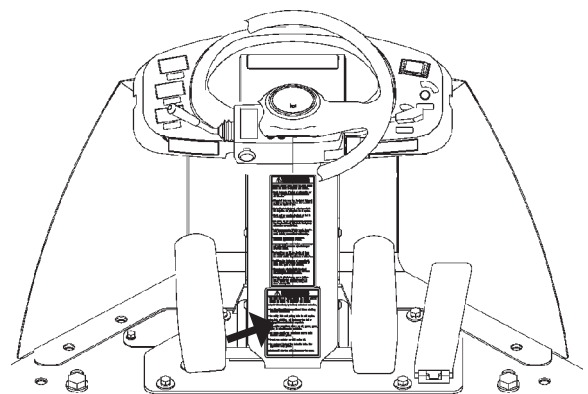

SS-4172

## SAFETY SIGNS

### 9. Both Side Vicinity of Step's



SS-4EK-027\_E

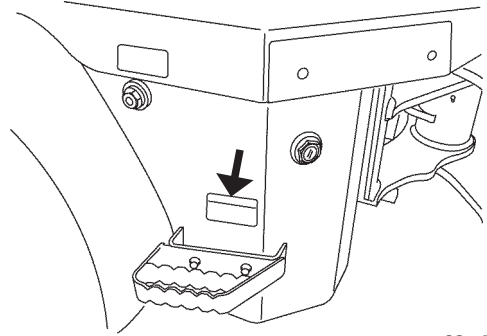

SS-4EK-009\_E

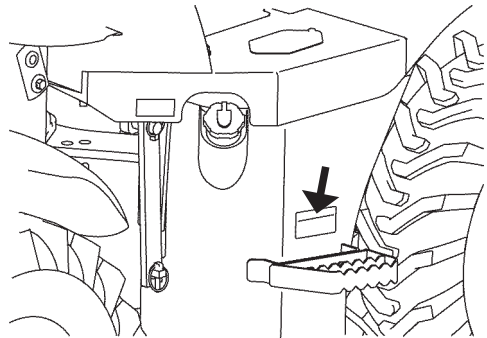

SS-4EK-006\_E

### 10. Relay Box Cover

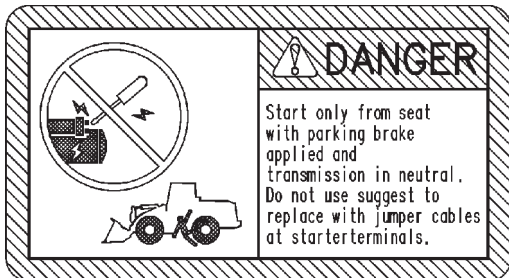

SS-4173

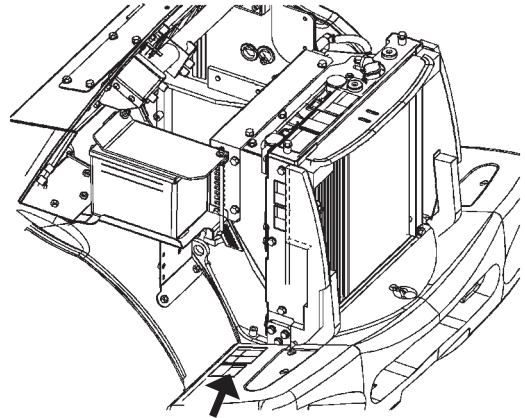

SS-NBD-001

- If the engine is started following an incorrect method, the machine suddenly may begin to move. Start the engine from the operator's seat only.

## SAFETY SIGNS

### 11. Vicinity of Battery

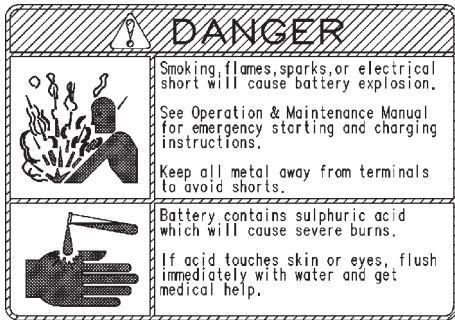

SS-4174

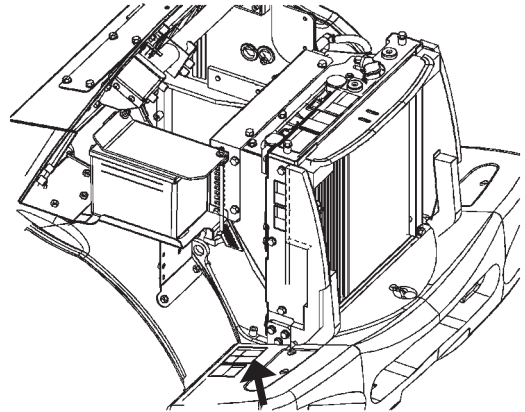

SS-NBD-001

- Skin contact with electrolyte will cause burns. Splashed electrolyte into eyes will cause blindness. Take care not to touch electrolyte.

### 12. Vicinity of Radiator Cap



SS-4175

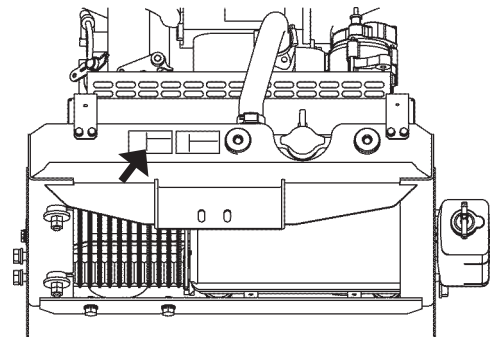

SS-E804-004\_E

- Sign indicates a burn hazard from spurting hot water or oil if radiator or hydraulic tank is uncapped while hot. Allow radiator or hydraulic tank to cool before removing cap.

### 13. Left Side of Radiator Cap

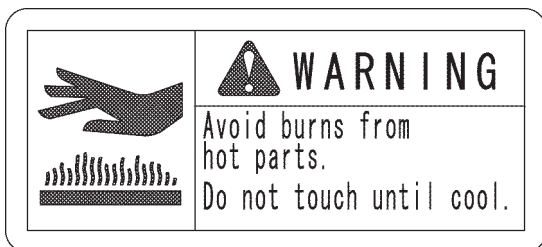

SS-4EK-032\_E

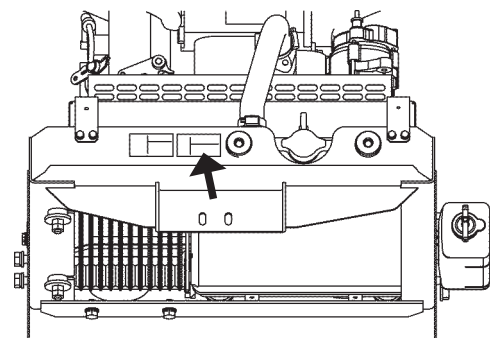

SS-E804-004\_E

- Avoid skin contact with highly heated parts such as the engine, muffler, etc. immediately after operation of the machine. Severe burns may result.

## SAFETY SIGNS

### 14. Both Sides of Radiator Frame

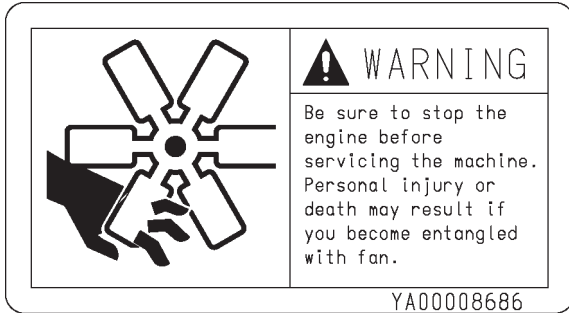

SSYA00008686

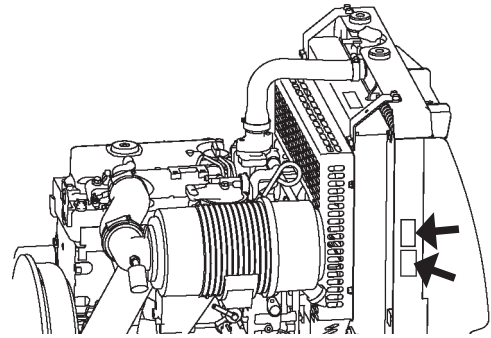

M4ER-00-001

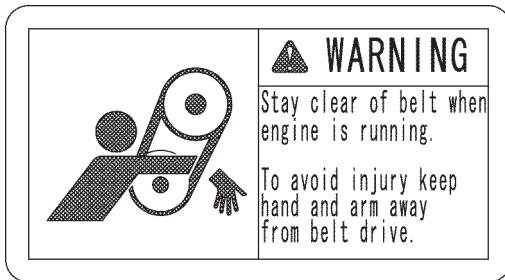

SS-4EK-033\_E

- Side indicates a hazard of rotating parts, such as belt fan. Turn off before inspection and maintenance.

### 15. Vicinity of Air Cleaner

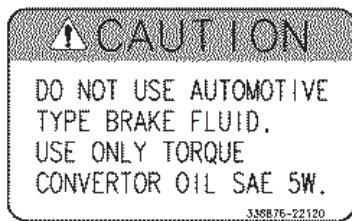

SS-4EK-035\_E

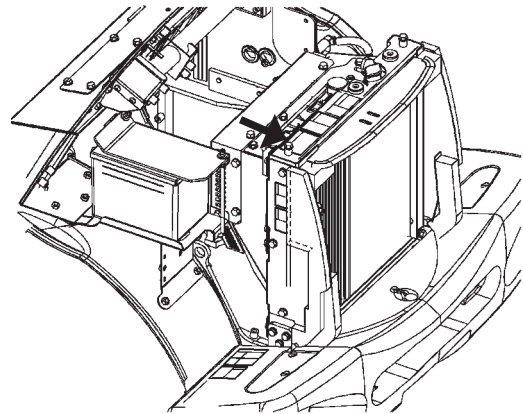

SS-NBD-001

### 16. Both Sides of Counterweight

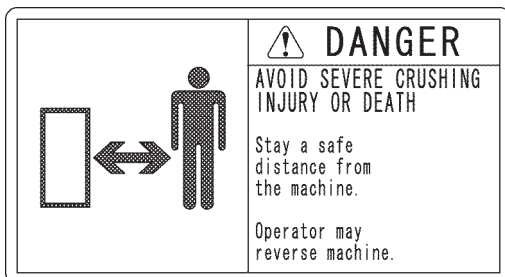

SS-4EK-039\_E

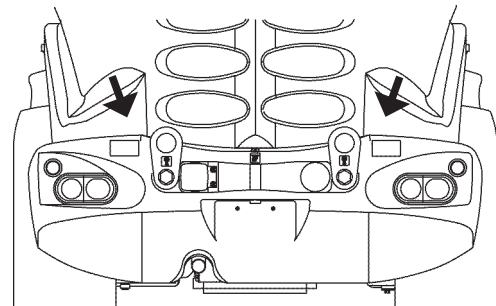

SS-E804-005\_E

- Avoid machine reversing injuries. Keep everyone far away from the machine during operation.

## SAFETY SIGNS

### 17. Left Side of Front Frame

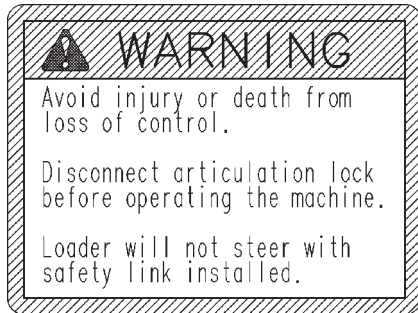

SS-4176

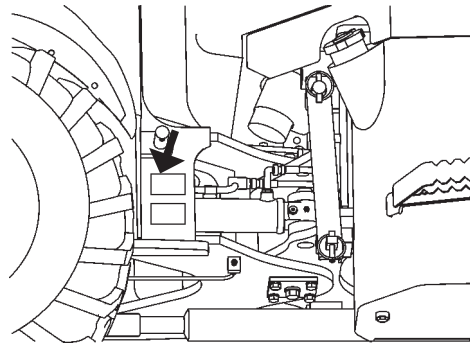

- The articulation area becomes a pinch point when steering the machine. Be sure to install the articulate lock bar during the inspection/maintenance work and transportation of the machine. Remove link when finished.

### 18. Both Sides of Front Frame



SS-4177

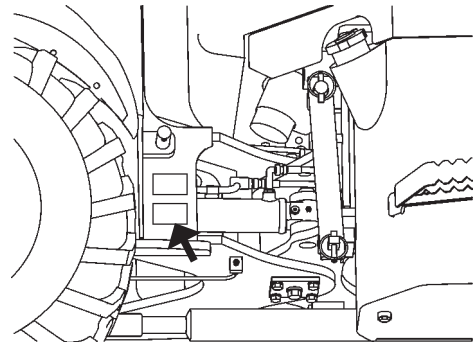

- The articulation area becomes a pinch point when steering the machine. Keep all personnel away from the articulation area during operation of the machine.

### 19. Both Sides of Front Frame

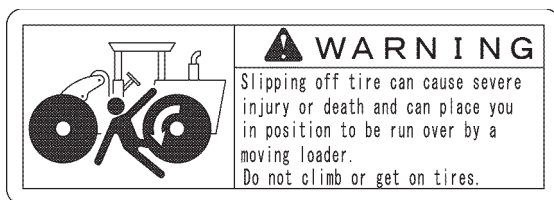

SS-4EK-042\_E

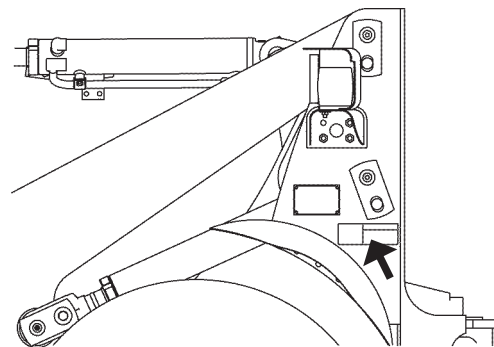

- Sign indicates a hazard of rotating parts, such as belt. Turn off before inspection and maintenance.

## COMPONENTS NAME

### Components Name

#### Canopy Vehicle

- 1- Cutting Edge
- 2- Bucket
- 3- Bucket Link
- 4- Bell Crank
- 5- Bucket Cylinder
- 6- Head Light/Turn Signal/Clearance Light
- 7- Rear View Mirror
- 8- ROPS/FOPS Canopy
- 9- Fuel Filler Port
- 10- Articulation Lock Bar (Left Side only)
- 11- Lift Arm Cylinder
- 12- Lift Arm
- 13- Hydraulic Oil Tank
- 14- Combination Lamp  
(Turn signal/Tail Light/Brake Light)
- 15- Counterweight
- 16- Towing Pin
- 17- Backup Light and Alarm
- 18- Radiator/Oil Cooler

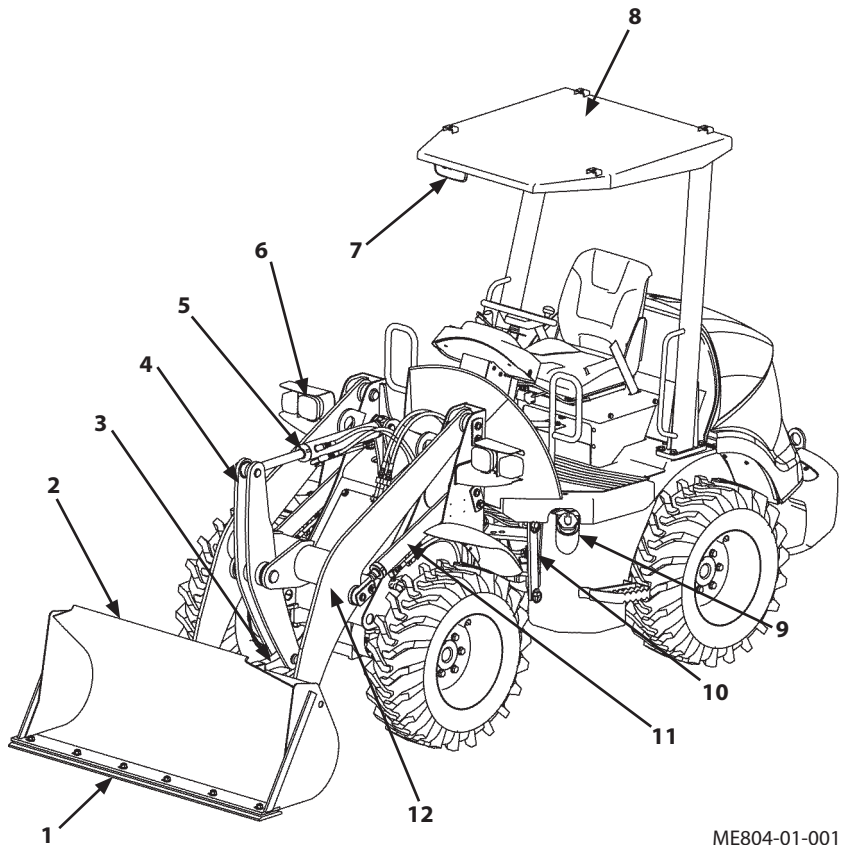

ME804-01-001

 **NOTE:** Illustrations on this page are those for the typical model. They may appear differently on other models.

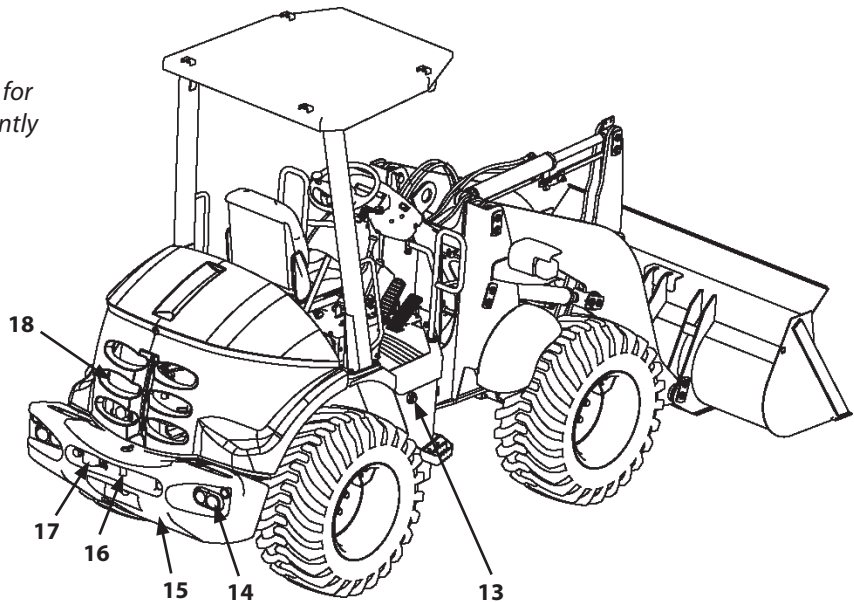

M4ER-01-006

## COMPONENTS NAME

### Cab Vehicle (Optional)

- 1- Cutting Edge
- 2- Bucket
- 3- Bucket Link
- 4- Bell Crank
- 5- Bucket Cylinder
- 6- Head Light/Turn Signal/Clearance Light
- 7- Rear View Mirror
- 8- Front Work Light
- 9- ROPS/FOPS Cab
- 10- Rear Work Light
- 11- Fuel Filler Port
- 12- Articulation Lock Bar (Left Side only)
- 13- Lift Arm Cylinder
- 14- Lift Arm
- 15- Hydraulic Oil Tank
- 16- Combination Lamp  
(Turn signal/Tail Light/Brake Light)
- 17- Counterweight
- 18- Towing Pin
- 19- Backup Light and Alarm
- 20- Radiator/Oil Cooler

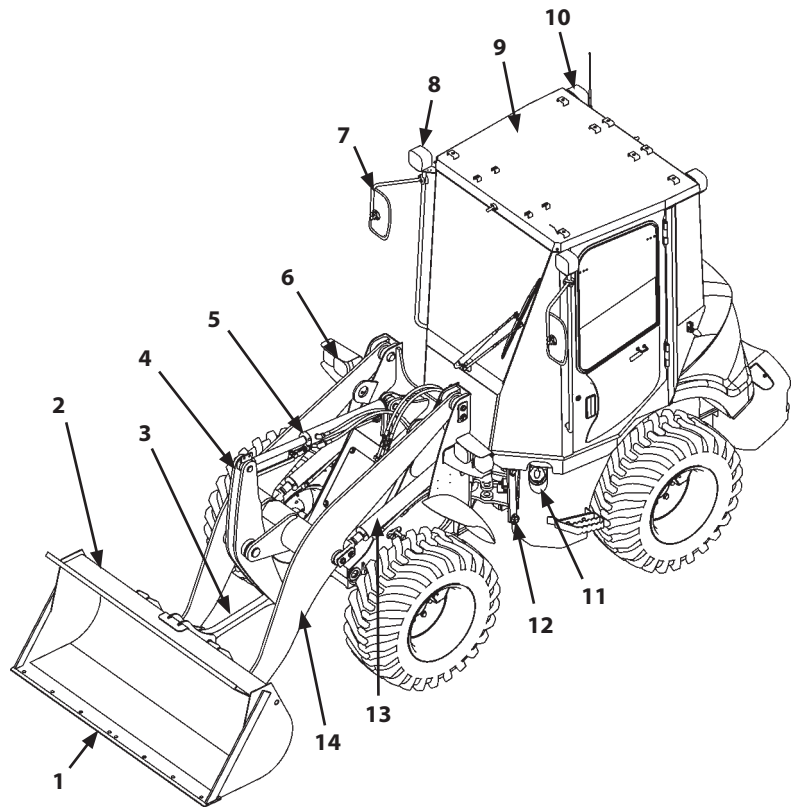

M4ER-01-001

**NOTE:** Illustrations on this page are those for the typical model. They may appear differently on other models.

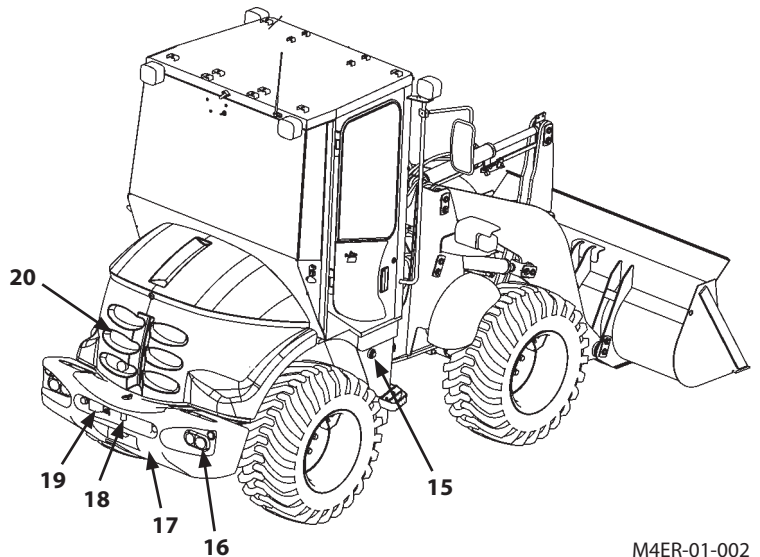

M4ER-01-002



## GETTING ON/OFF THE MACHINE

### Getting ON/OFF the Machine

Foot holds (1) and handrails (2) are provided in and around the machine.

These are used to get on and off the cab safely as well as to do inspection and maintenance of the machine safely.

Never jump on or off the machine as it is very dangerous.

#### **⚠ WARNING:**

- **Never attach a wire on the foot holds (1) to lift the cab or main body or while transporting the machine on a truck or trailer as it is dangerous.**
- **The door handle (3) is not a handrail. Do not hold the door handle (3) as a handrail when getting on and off the machine.**
- **Do not hold the control levers (4), steering wheel or forward/reverse lever when getting on and off the machine.**

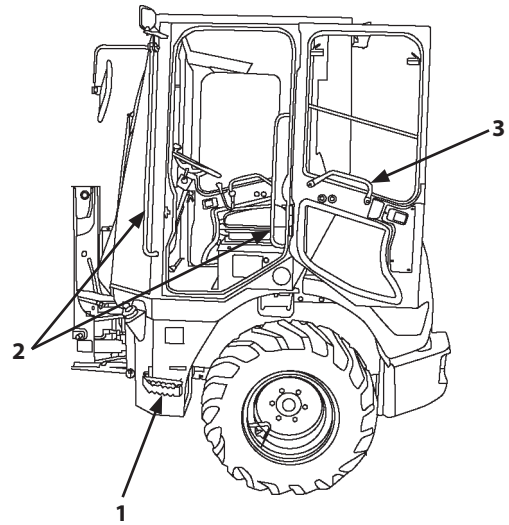

M4EK-01-065

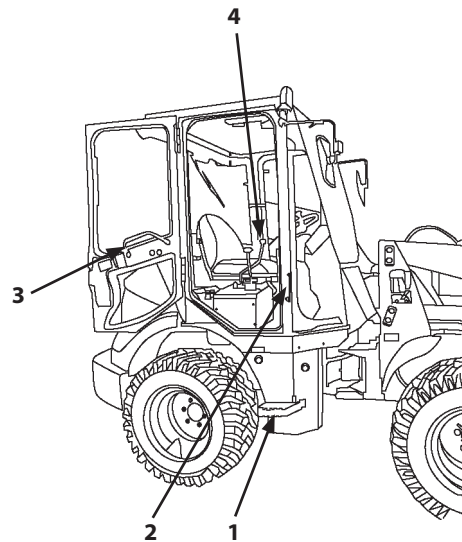

M4EK-01-064

## OPERATOR'S STATION

---

### Features

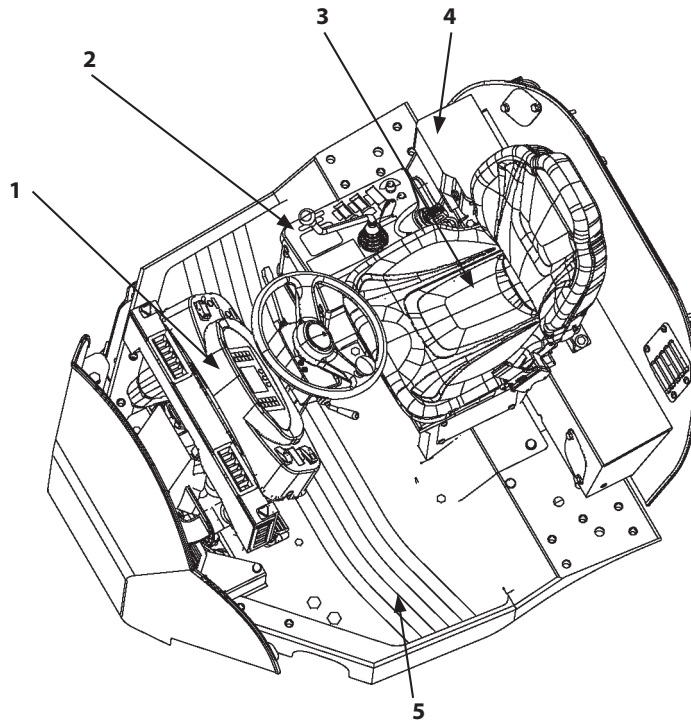

MNBC-01-006

- 1- Front Console
- 2- Right Console
- 3- Operator's Seat
- 4- Fuse Box
- 5- Floor Mat

# OPERATOR'S STATION

## Front Console

- 1- Steering Wheel
- 2- Horn Switch
- 3- Monitor Panel
- 4- Accelerator Pedal
- 5- Brake/Inching Pedal (Both right and left sides are interlocked)
- 6- Forward/Reverse Lever
- 7- Neutral Lever Lock (Forward/Reverse Lever)
- 8- Rear Work Light Switch (CAB: Optional)
- 9- Front Work Light Switch (CAB)
- 10- Hazard Switch (Optional)
- 11- Turn Signal Switch
- 12- Paring Brake Switch
- 13- Front Window Wiper Switch (CAB)
- 14- Rear Window Wiper Switch (CAB)
- 15- Light Switch

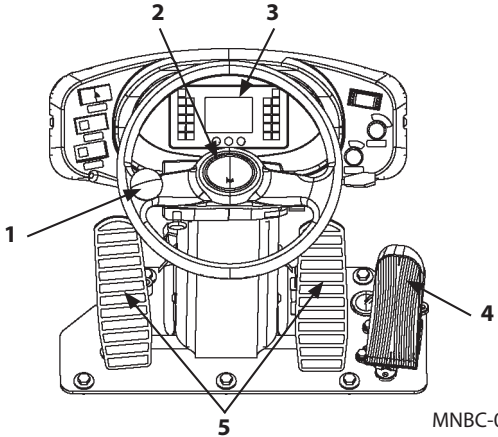

MNBC-01-007

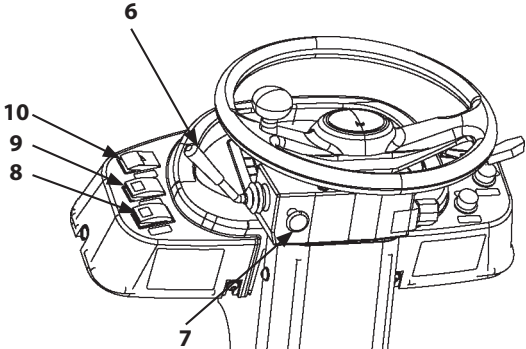

MNBC-01-008

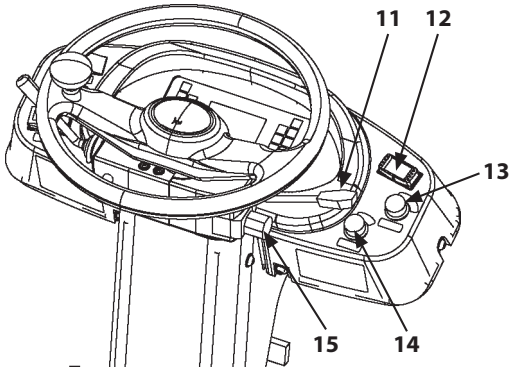

MNBC-01-009

## OPERATOR'S STATION

### Right Console

- 1- Loader Control Lever
- 2- Loader Control Lever Lock
- 3- Auxiliary
- 4- Travel Mode Switch (Optional)
- 5- Heater Switch (Optional)
- 6- Key Switch

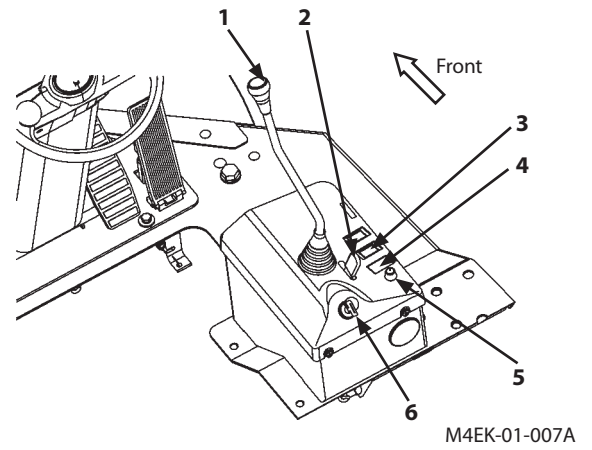

## OPERATOR'S STATION

### Monitor Panel

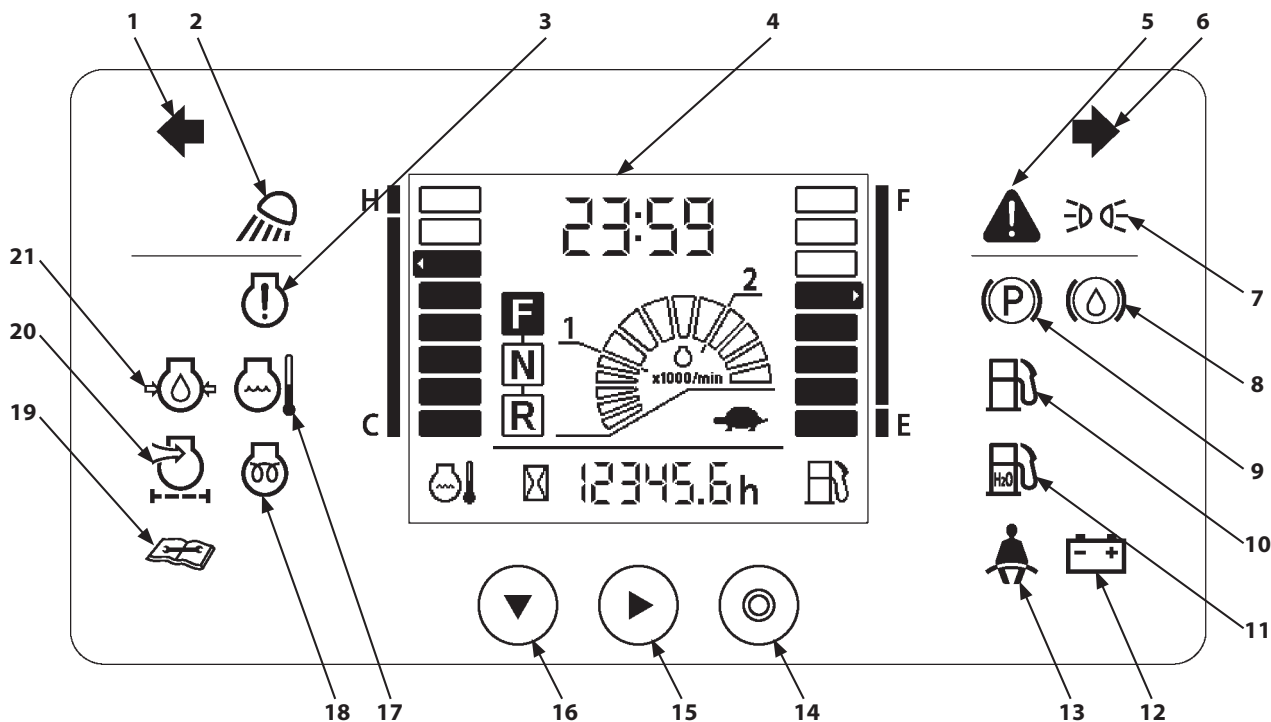

MNBC-01-020

- |                                 |                                   |
|---------------------------------|-----------------------------------|
| 1- Left Turn Signal Indicator   | 13- Seat Belt Indicator           |
| 2- Work Light Indicator         | 14- Set Switch                    |
| 3- Engine Error Alarm           | 15- Select Switch                 |
| 4- Monitor Display              | 16- Select Switch                 |
| 5- Service Indicator            | 17- Overheat Indicator            |
| 6- Right Turn Signal Indicator  | 18- Preheat Indicator             |
| 7- Clearance Light Indicator    | 19- Maintenance Light             |
| 8- Brake Level Low Indicator    | 20- Air Cleaner Restriction Alarm |
| 9- Parking Brake Indicator      | 21- Engine Oil Pressure Indicator |
| 10- Fuel Level Indicator        |                                   |
| 11- (Not In Use)                |                                   |
| 12- Discharge Warning Indicator |                                   |

## OPERATOR'S STATION

---

### Service Indicator (Yellow)

**⚠ WARNING:** To prevent potential injury and/or damage to the machine, immediately stop operating the machine if the service indicator lights or the alarm sounds. Then check and service the part indicated.



M4GB-01-011

The service indicator comes on and the buzzer sounds in the following cases. Stop working immediately and move to a safe location. Stop the machine and the engine. Contact your authorized dealer.

- If the engine oil pressure drops
- If the engine coolant becomes abnormally hot
- If the level of the brake fluid drops

The service indicator comes on in the following cases. Stop the engine as soon as possible and troubleshoot the cause.

- If there is a problem with the engine
- If the air cleaner is clogged

**✎ NOTE:** When the key switch is turned ON, the various indicators and the service indicator  light up and the buzzer sounds for about 2 seconds, as a check for whether any lamp(s) or the buzzer is burnt out. If a lamp fails to light, it may be burnt out. If the buzzer fails to sound, the buzzer may be malfunctioning. Consult your authorized dealer.

## OPERATOR'S STATION

---

### Parking Brake Indicator (Red)

The parking brake indicator lights when the parking brake is ON.



M4GB-01-012

### Brake Level Low Indicator

**⚠ WARNING:** Personal injury may result from continuing to operate the machine when the brake fluid level is low. If the red light comes ON, immediately stop the machine.

If the brake fluid level drops, the brake level low indicator lights, the service indicator lights and the buzzer sounds. Stop the machine right away and check for leaks in the brake system.



M4GB-01-014

### Discharge Warning Indicator (Red)

If the voltage from the alternator is low, the discharge warning indicator comes ON. If the voltage from the alternator is abnormally high, the discharge warning indicator and the service indicator turn on. Check the alternator and the battery systems.

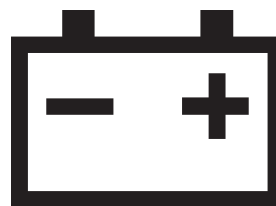

M4GB-01-018

### Engine Error Alarm (Red)

The indicator lights if a major problem with the engine or engine-related parts occurs.

If the engine error indicator and/or the service indicator lights, move to a safe place right away, put it in its parking configuration and stop the engine. Then, consult your authorized dealer.



M4GB-01-019

## OPERATOR'S STATION

---

### Overheat Indicator (Red)

The warning light comes on if the engine coolant becomes abnormally hot. The overheat indicator and service indicator come on and the buzzer alarm sounds. Stop operations and run the engine at slow idle speed to lower the coolant temperature.



M4GB-01-020

### Engine Oil Pressure Indicator (Red)

**⚠ WARNING:** If the engine is run with its engine oil pressure low, it may damage the engine. If the indicator comes ON, immediately stop working and stop the engine.

If the engine oil pressure drops, the engine oil pressure indicator and service indicator come ON and the buzzer sounds. Move to a safe place right away, put the machine in its parking configuration and stop the engine. Then check the engine oil system and oil level.

**📌 NOTE:** The oil being cold or operating on a very steep slope may also cause the indicator to light.



M4GB-01-021

### Air Cleaner Restriction Alarm (Red)

If the air cleaner element is restricted, both the air cleaner restriction indicator and the service indicator come ON. Stop the machine and the engine right away; then check the air cleaner element. Clean or replace the element as needed.

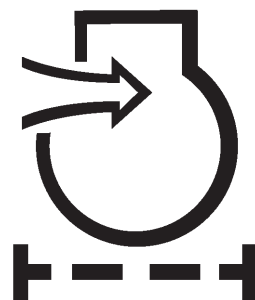

M4GB-01-023



## OPERATOR'S STATION

---

### Preheat Indicator (Yellow)

When lit, it indicates that the engine is preheating; once it goes out, preheating is complete.



M4GB-01-031

### Seat Belt Indicator (Red)

The indicator comes on if the engine is started without the seat belt being fastened; once the belt is fastened the light goes out. It lights when the key switch is in the ON position, regardless of whether the seat belt is fastened. The indicator goes out 5 seconds after the engine is started if the seat belt is fastened.



MNBC-01-021

### Fuel Level Indicator (Orange)

This indicator lights when the fuel is low. On flat ground, it lights when there are 9 liters left in the tank. Refill as soon as possible.



MNBC-01-022

## OPERATOR'S STATION

---

### Turn Signal Indicator (Green)

When the turn signal lever is operated, the turn signal and the indicator start flashing.



M4GB-01-032

### Work Light Indicator (Yellow)

When the work lights are turned ON, this indicator comes ON.



MNBC-01-023

### Clearance Light Indicator (Green)

When the clearance lights are turned ON, this indicator comes ON.



M4GB-01-035

## OPERATOR'S STATION

---

### Maintenance Light (Yellow)

This light indicates that the time for a replacement is approaching. Once the set time is reached, it lights for 30 seconds each time the key switch is turned ON.



M4GB-01-037

### Items with Replacement Times

- Engine Oil
- Engine Oil Filter
- Fuel Filter
- Oil Separator
- Transmission Oil
- Front Axle Oil
- Rear Axle Oil
- Hydraulic Oil
- Hydraulic Filter (Return Filter)
- Hydraulic Filter (HST Oil Filter)

# OPERATOR'S STATION

## Monitor Display

1. Monitor Display
2. Set Switch
3. Select Switch
4. Select Switch
5. Clock
6. Engine Tachometer
7. Fuel Gauge
8. Travel Mode Indicator (Optional)
9. Hour Meter
10. Coolant Temperature Gauge
11. F-N-R Indicator

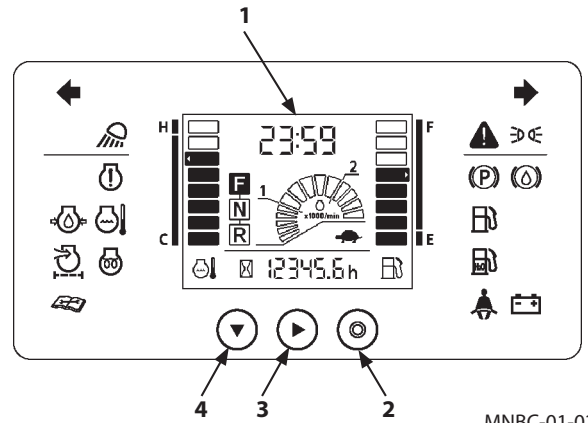

MNBC-01-024

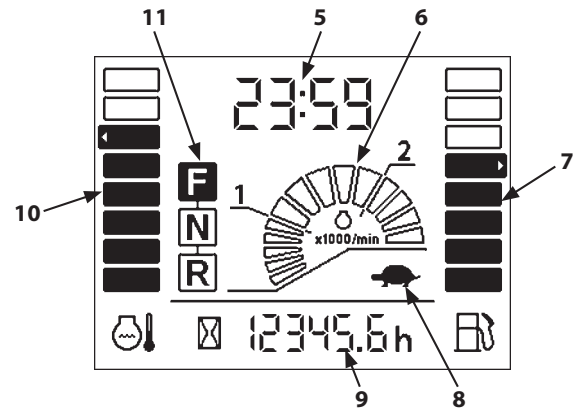

MNBC-01-025

# OPERATOR'S STATION

## F-N-R Indicator

The square corresponding to the position of F-N-R lever (3), highlights either Forward (F), Neutral (N) or Reverse (R) in F-N-R indicator (1).

Neutral is highlighted whenever the parking brake switch is ON, regardless of the lever position.

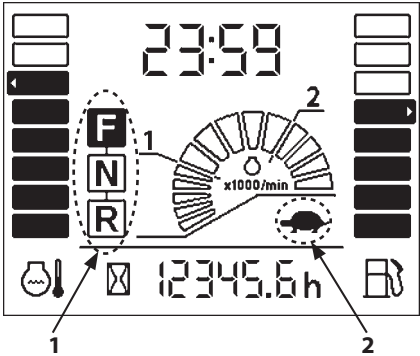

MNBC-01-025

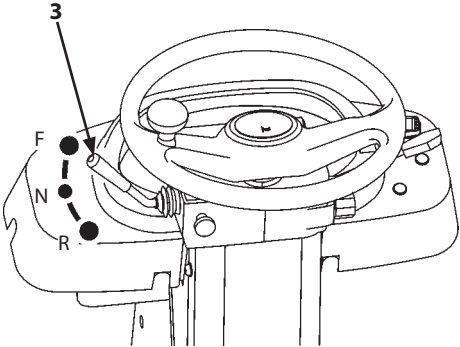

M4EK-01-008

## Travel Mode Indicator (Optional)

Travel mode indicator (2) indicates it when travel mode switch (4) (optional) is in the LOW mode.

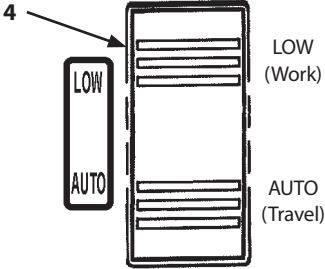

M4EJ-01-090

## OPERATOR'S STATION

### Hour Meter

The total accumulated operating hours since the machine started working are displayed in hours (h). One digit after the decimal point indicates tenths of an hour (6 minutes).



MNBC-01-026

### Clock

Indicates the current time.  
(Refer to "Clock" for instructions on setting the clock.)



MNBC-01-027

### Fuel Gauge

Indicates the amount of remaining fuel. Refuel before the indicator segment reaches "E". If the fuel sensor circuit malfunctions, all segments of the fuel gauge flash.

**IMPORTANT: If all segments flash, there is a problem with the machine. Immediately consult your authorized dealer.**



MNBC-01-028

### Coolant Temperature Gauge

Indicates the engine coolant temperature. Normally the needle is around the center of the scale during operation.

**IMPORTANT: If all segments flash, there is a problem with the machine. Immediately consult your authorized dealer.**



MNBC-01-029

### Engine Tachometer

The tachometer indicates the engine speed. (200 min<sup>-1</sup> increments)

**IMPORTANT: If all segments flash, there is a problem with the machine. Immediately consult your authorized dealer.**

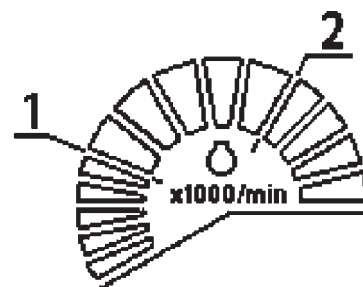

MNBC-01-030

## OPERATOR'S STATION

### Time

#### Setting the Clock

1. Press and hold set switch (1) and selector switch (3) together for about 1 second on the basic screen to enter the clock setting mode, causing hour display (4) to flash.
2. Push selector switch (2) or (3) to adjust the hour in hour display (4). Push selector switch (2) to lower the number, and push switch (3) to increase it. Holding the switches for 2 seconds makes the numbers continue to change.
3. Once the desired number is reached, press set switch (1) to set it. Once the hour is set, minute display (5) starts flashing and it can be adjusted.
4. Set the minutes on minute display (5) in the same way as in step 2.
5. Once the desired number is reached, press set switch (1) to set it. Once the minute display is set, the clock setting is complete.

 **NOTE:** The clock resets to default if the battery is removed or the battery disconnect switch (optional) is turned OFF.

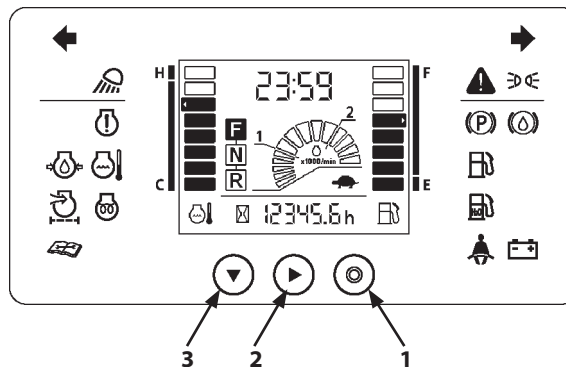

MNBC-01-024



MNBC-01-027

# OPERATOR'S STATION

## Maintenance

The remaining hours until next maintenance can be checked and reset on the maintenance screen.

### Checking Hours until Next Maintenance

1. Press selector switch (1) from the basic screen to open the maintenance screen.



: Hours until next maintenance



: Maintenance interval (fixed value)

2. Continuing to hold selector switch (1) down scrolls through the items in order: 1.Engine, 2.Power train and 3.Hydraulic system. The following items have been set up for the different screens.

#### Maintenance Items

##### 1. Engine

- Engine Oil
- Engine Oil Filter
- Fuel Filter
- Oil Separator

##### 2. Powertrain

- Transmission Oil
- Front Axle Oil
- Rear Axle Oil

##### 3. Hydraulic System

- Hydraulic Oil
- HST Oil Filter
- Return Filter

3. Push selector switch (1) to return to the basic screen.

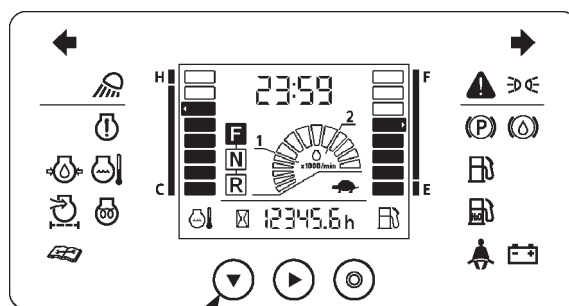

MNBC-01-024

Push selector switch (1).

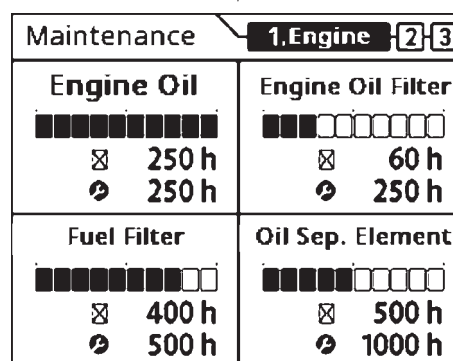

MNBC-01-031\_E

Push selector switch (1).

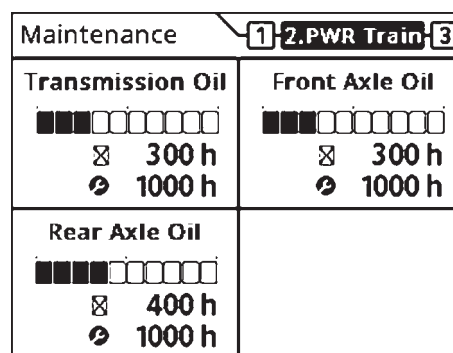

MNBC-01-032\_E

Push selector switch (1).

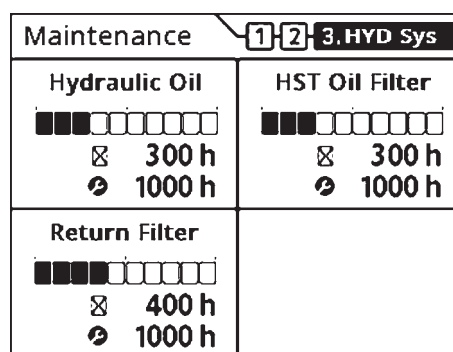

MNBC-01-033\_E

Push selector switch (1).



## OPERATOR'S STATION

### Resetting Hours until Next Maintenance

When an item reaches its maintenance time, maintenance lamp (4) lights.

A wrench mark (5) is displayed on the maintenance screen above items that have reached their maintenance times.

Perform the required maintenance for items that have reached their maintenance times and then reset the remaining time after completing the maintenance.

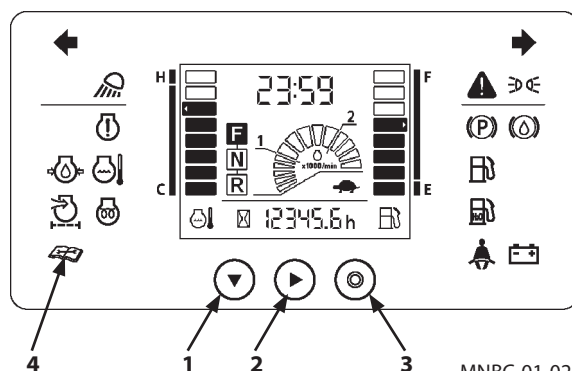

MNBC-01-024

Push selector switch (1).

1. Press selector switch (1) from the basic screen to open the maintenance screen.

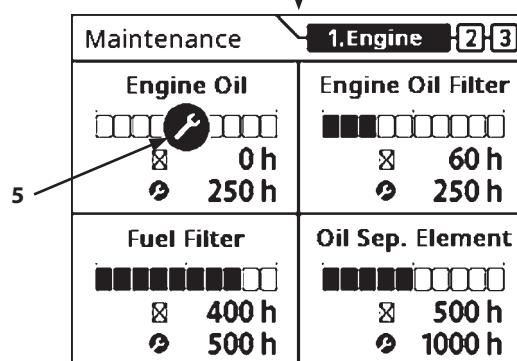

MNBC-01-034\_E

Push selector switch (2).

2. Press selector switch (2) to highlight item(s) that have not been reset. (The illustration at right shows Engine Oil is selected.)

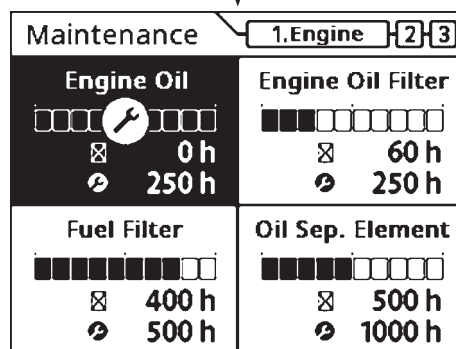

MNBC-01-035\_E

Long press set switch (3).

3. Long press set switch (3) for at least 2 seconds and it resets and the buzzer sounds. The hours until next maintenance (⊗) becomes the same amount of time as the maintenance interval (⌚).

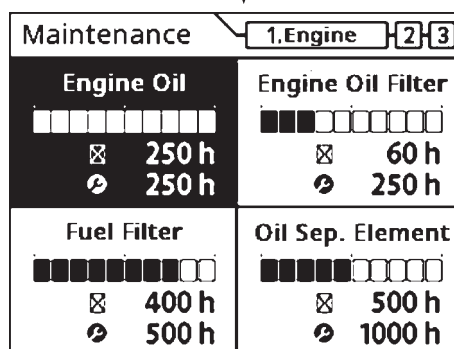

MNBC-01-036\_E

Push selector switch (1).

4. Push selector switch (1) to return to the basic screen.

## OPERATOR'S STATION

### Switches, Steering Wheel and Pedals

- 1- Steering Wheel
- 2- Horn Switch
- 3- Monitor Panel
- 4- Accelerator Pedal
- 5- Brake/Inching Pedal (Both right and left sides are interlocked)
- 6- Forward/Reverse Lever
- 7- Neutral Lever Lock (Forward/Reverse Lever)
- 8- Rear Work Light Switch (CAB: optional)
- 9- Front Work Light Switch (CAB)
- 10- Hazard Switch (Optional)
- 11- Turn Signal Switch
- 12- Paring Brake Switch
- 13- Front Window Wiper Switch (CAB)
- 14- Rear Window Wiper Switch (CAB)
- 15- Light Switch

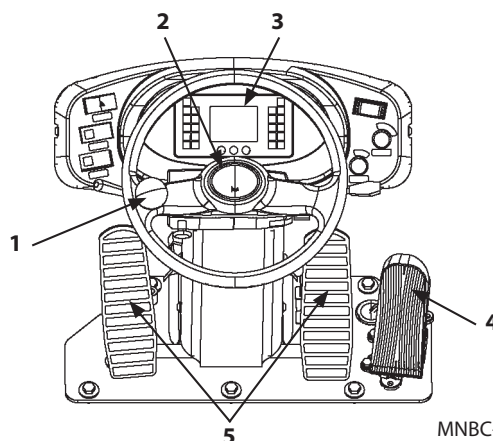

MNBC-01-007

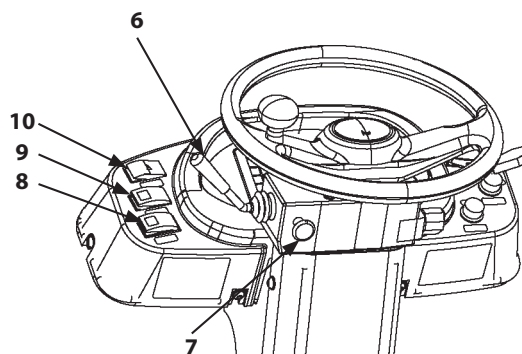

MNBC-01-008

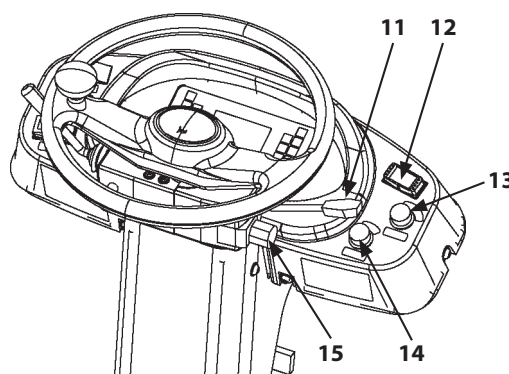

MNBC-01-009

## OPERATOR'S STATION

### Forward/Reverse Lever

Changes the machine drive direction from forward to reverse and vice versa. Move forward/reverse lever (1) to the F position to travel the machine forward. Move forward/reverse lever (1) to the R position to drive the machine in reverse.

**IMPORTANT:** Do not shift forward/reverse lever (1) while driving the machine at high speed. Failure to do so may damage the transmission.

 **NOTE:** The engine will not start if the forward/reverse lever (1) are not in the neutral position.  
To ensure safety, set neutral lock lever (2) in the LOCK position (3).

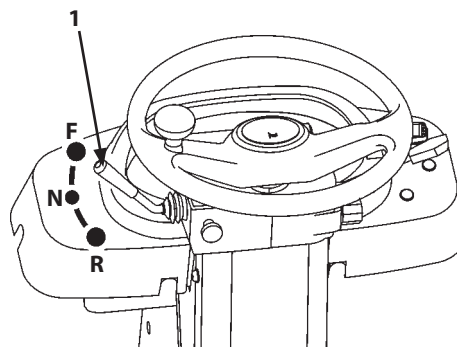

M4EK-01-008

### Neutral Lever Lock (Forward/Reverse Lever)

 **WARNING:** When the machine is parked or serviced, be sure to place neutral lever lock (2) in the LOCK position (3).

The neutral lever lock makes the forward/reverse lever immovable so that the machine does not start moving even if a body part comes in contact with the forward/reverse lever by mistake.

Before starting the engine, set neutral lever lock (2) in the LOCK position (3).

PUSH (3): LOCK Position  
PULL (4): UNLOCK Position

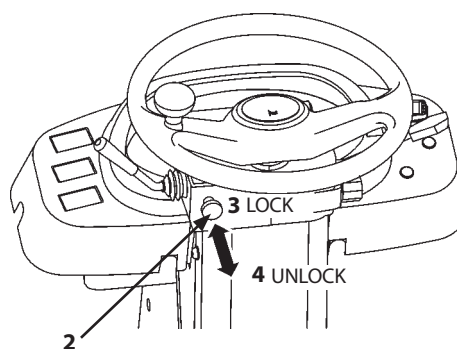

M4EK-01-009

## OPERATOR'S STATION

---

### Steering

**IMPORTANT:** When steering wheel (1) is fully turned, the front frame and the rear frame come in contact with the stoppers so that the steering wheel can not turn further. If forced to turn further, engine stall and/or damage to the steering system may result.

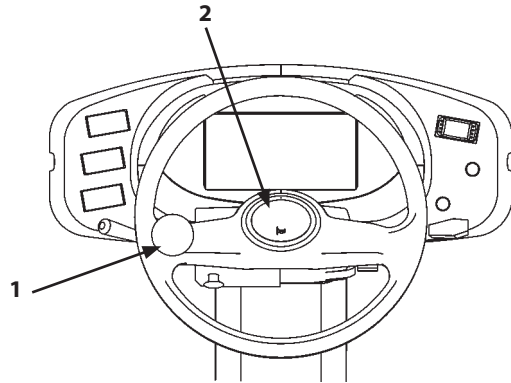

MNBC-01-011

### Horn Switch

Press horn switch (2) to sound the horn.

### Turn Signal Lever

Indicates the drive change direction to persons and/or other vehicles by operating turn signal lever (3). Return turn signal lever (3) to neutral manually.

- 4- Left Turn
- 5- Right Turn

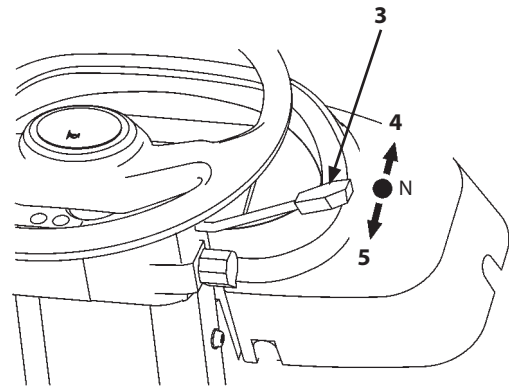

M4EK-01-011

## OPERATOR'S STATION

### Light Switch

Light switch (1) has three positions, OFF, Small, and Main. As shown below, each light comes ON (☀) or OFF (✕) according to the selected position of the light switch.

- 2- Headlight
- 3- Turn Signal/Clearance Light/Hazard Light
- 4- Turn Signal/Hazard Light
- 5- Brake Light/Tail Light

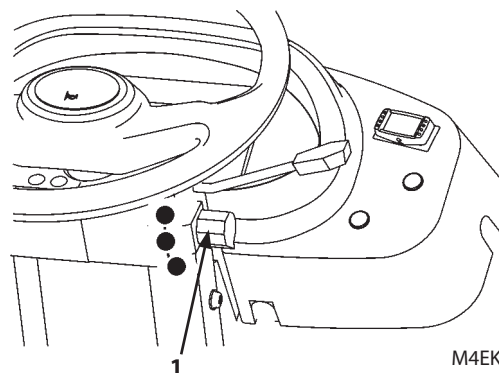

Light Switch Position	Headlight	Clearance Light	Tail Light	Monitor Panel Light
OFF	✕	✕	✕	✕
☀☀	✕	☀	☀	☀
☀☀☀	☀	☀	☀	☀

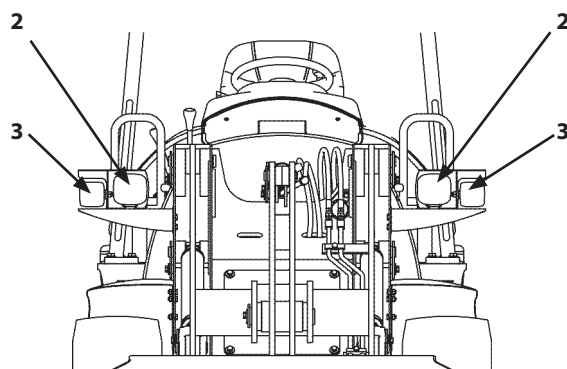

**NOTE:** Even though the key switch is turned OFF, as long as the light switch is in ☀☀ position, all lights except the headlight stay ON.

*This function is used as a parking light on a public road.*

**IMPORTANT:** Take care not to use the above switch function for a long time with the engine OFF. The batteries will be discharged.

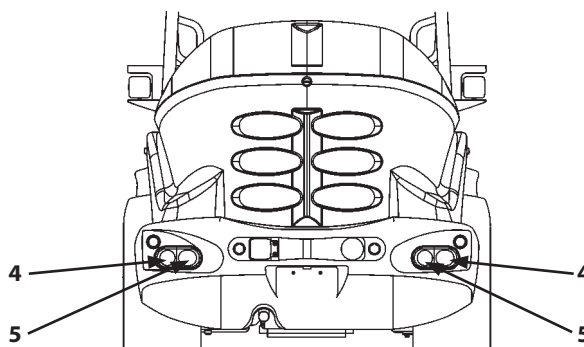

# OPERATOR'S STATION

## Hazard Switch (Optional)

**IMPORTANT:** Do not hold hazard switch (1) in the "▲" position for a long time with the engine stopped. The batteries will be discharged.

When a machine failure occurs, use this switch to inform other vehicles that the machine is in an emergency situation. When the position marked with "▲" on hazard switch (1) is pressed, front and rear turn signals (hazard light) (2) on both right and left sides starts flashing.

Press the opposite side of hazard switch (1) to turn the hazard signals OFF.

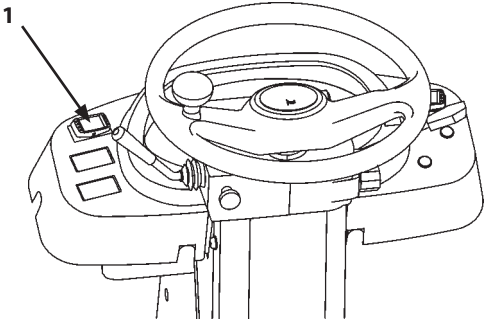

M4EK-01-015

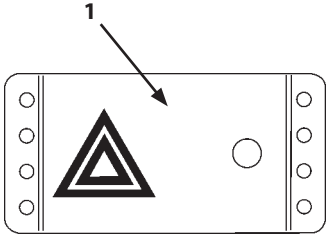

M4EK-01-016

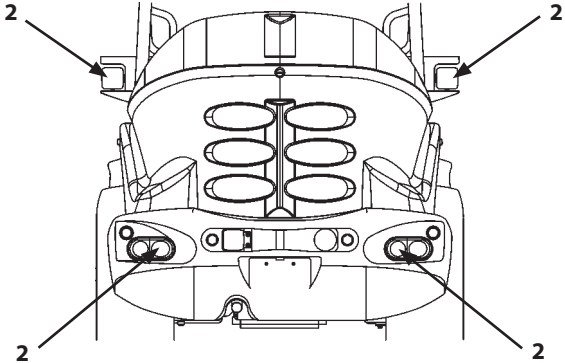

M4EK-01-014

# OPERATOR'S STATION

## Front Work Light Switch (Cab)

With the light switch (3) in either or position, press the ON side of front work light switch (1) to turn front work lights (2) ON. Press the OFF side of front work light switch (1) to turn front work lights (2) OFF. When front work lights (2) turn ON, green light (4) on front work light switch (1) turns ON.

**CAUTION:** Do not turn the work lights ON while driving on a public road.

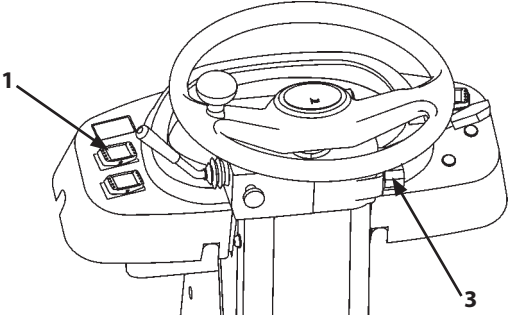

M4EK-01-020

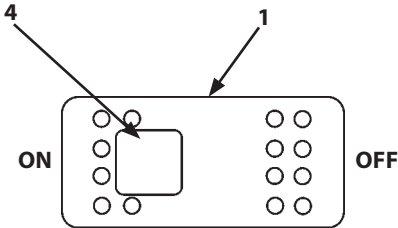

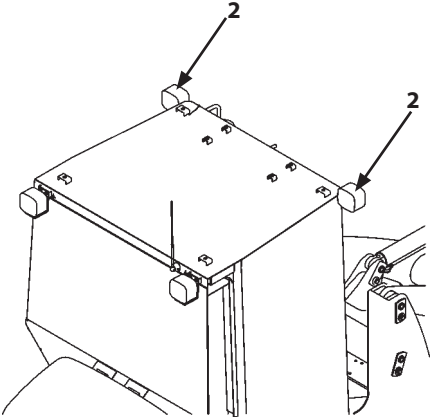

M4EK-01-021



M4EK-01-022

# OPERATOR'S STATION

## Rear Work Light Switch (Cab, Optional)

With the light switch (3) in either  or  position, press the ON side of rear work light switch (1) to turn rear work lights (2) ON. Press the OFF side of rear work light switch (1) to turn rear work lights (2) OFF. When rear work lights (2) turn ON, green light (4) on rear work light switch (1) turns ON.

**CAUTION:** Do not turn the work lights ON while driving on a public road.

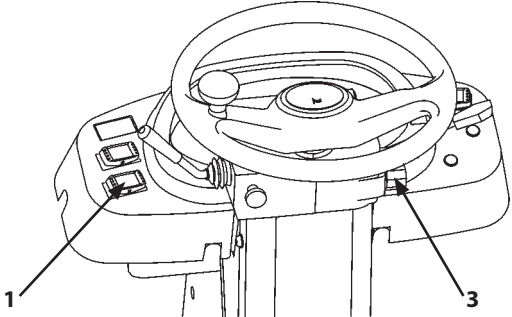

M4EK-01-020

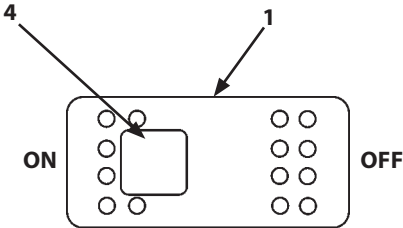

M4EK-01-021

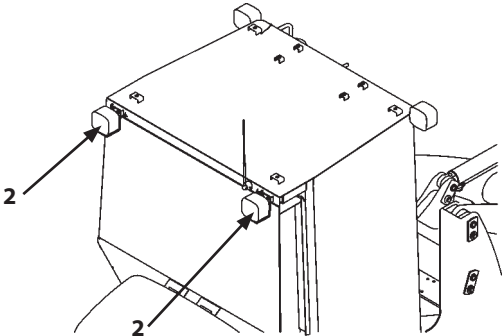

M4EK-01-022



## OPERATOR'S STATION

### Parking Brake Switch

**WARNING:** To prevent accidents due to rolling of the machine, after parking the machine or before leaving the machine, be sure to apply the parking brake. Never apply the parking brake while traveling the machine. Failure to do so may cause sudden deceleration of the machine travel speed, possibly creating a dangerous situation. Apply the parking brake only after the machine has stopped.

Do not apply the parking brake while the machine is moving except in an emergency. If the parking brake was applied while traveling the machine because of an emergency, have the parking brake inspected by your nearest authorized dealer.

When parking brake switch (1) is turned ON, the parking brake is applied, lighting parking brake indicator (2). Press the OFF side of parking brake switch (1) to release the parking brake. Press to click the switch twice and then check that parking brake indicator (2) is turned OFF.

#### NOTE:

- The parking brake is released by hydraulic pressure only when the engine is running.
- To ensure safe operation, when the parking brake is applied, even though the forward/reverse selector lever is moved to forward (F) or reverse (R) position, the machine does not travel.
- To ensure safe operation, when the engine is stopped, the parking brake is applied even if parking brake switch (1) is in the OFF position. Before starting the engine, check that the forward/reverse lever is in the N position. Then, turn the parking brake switch (1) ON.

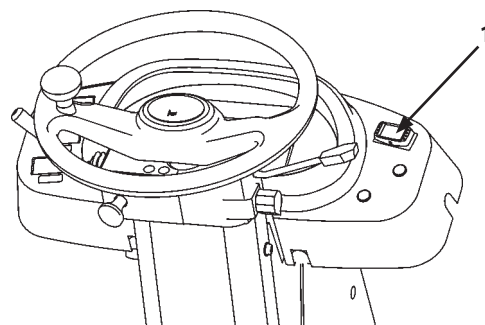

M4EK-01-006

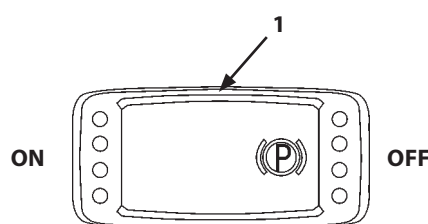

M4EK-01-025A

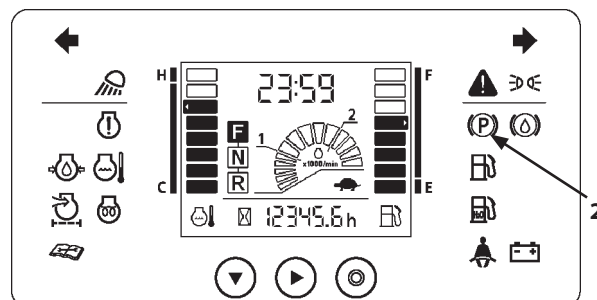

MNBC-01-024

## OPERATOR'S STATION

### Front Window Wiper Switch (Cab)

Operate front window wiper switch (1) to move the windshield wiper.

- OFF: The wiper stops moving and the wiper blade is returned to the pre-start position.
- LO: The wiper operates at slow speed
- HI: The wiper operates at fast speed.
- PUSH: As long as wiper switch (1) is depressed, the washer fluid is dispensed.

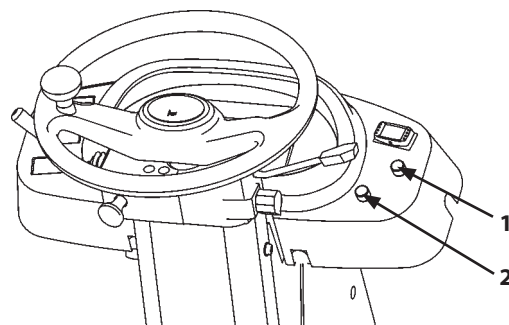

M4EK-01-024

**IMPORTANT: The washer motor may become damaged if washer fluid is continuously used for more than 20 seconds or the wiper switch is operated with no fluid in the washer tank. Take care about the switch operation time and the fluid level in the washer tank.**

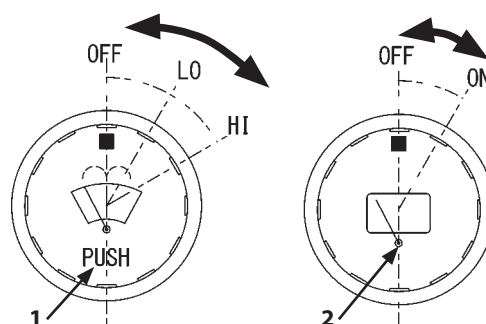

M4ER-01-003

### Rear Window Wiper Switch (Cab)

Operate rear window wiper switch (2) to move the windshield wiper.

- OFF: The wiper stops moving and the wiper blade is returned to the pre-start position.
- ON: The wiper operates.

## OPERATOR'S STATION

### Accelerator Pedal

When accelerator pedal (1) is stepped on, the engine speed increases. When released, the engine speed decreases.

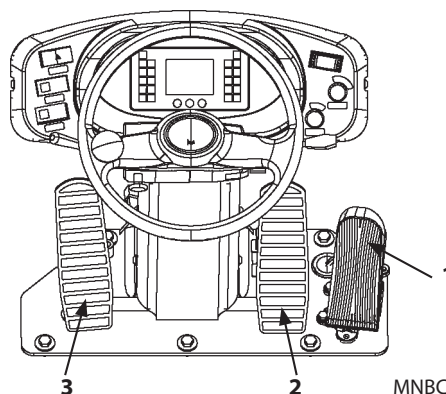

MNBC-01-007

### Brake/Inching Pedal

**⚠ WARNING:** Avoid sudden brake application during travel operation, possibly creating a hazardous situation. The machine may lose its balance. Unless necessary, do not place your foot on the brake/inching pedal to prevent the brake/inching pads and discs from wearing out prematurely.

**Keep the areas around the brake/inching pedals clean to prevent dust and/or grit from accumulating. Failure to do so may cause the brake/inching pedals to not fully release and become inoperable.**

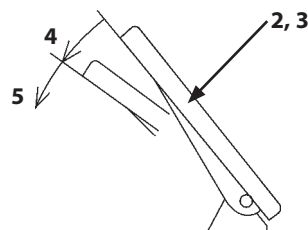

M4EJ-01-027

The machine brake is applied by stepping on the brake/inching pedal (2) or (3). When the brake/inching pedal is stepped on, the HST pump destrokes to neutral, causing the travel speed to reduce. When the brake/inching pedal is stepped on further, the service brake is activated, increasing braking force.

When the pedal is fully stroked, the machine is stopped regardless whether the Forward/Reverse lever is placed in the forward or reverse position, the engine power is transmitted only to the working devices. Accordingly, when the load handling lever is controlled by operating the accelerator pedal, the full engine power is used to operate the working devices.

## OPERATOR'S STATION

---

### Right Console

- 1- Loader Control Lever
- 2- Loader Control Lever Lock
- 3- Auxiliary
- 4- Travel Mode Switch
- 5- Key Switch

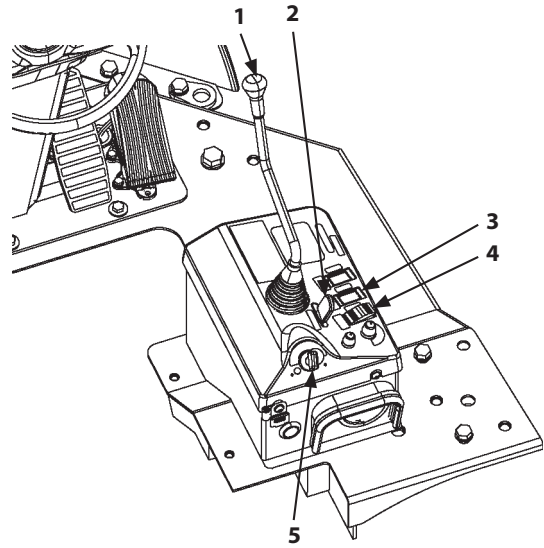

MNBC-01-010

## OPERATOR'S STATION

### Loader Control Lever

#### Mono-Lever Type

Is used to operate the lift arm and/or bucket.

- (C) Float: The lift arm free falls and can be moved as loads are applied.
- (B) Lift arm Lower
- (N) Hold: The lift arm and bucket are stopped and held in that position.
- (A) Lift arm Raise
- (E) Bucket Dump: The bucket is tilted forward to dump the bucket load.
- (D) Bucket Tilt: The bucket is tilted back, taking the transportation attitude.
- (G) Detent: When the loader control lever is moved from the bucket dump position to the bucket tilt position, the loader control lever is maintained in this position.

 **NOTE:** After dumping the bucket, when loader control lever (1) is pulled further from the TILT position (D), the lever is held in that position (G). Then, as soon as the bucket is tilted up to the position set by the bucket auto-leveler, loader control lever (2) is automatically returned to the HOLD position (N).

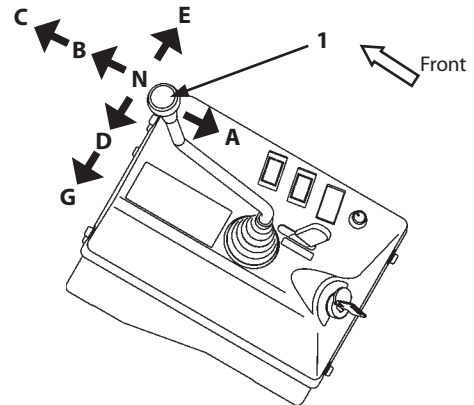

M4EK-01-007

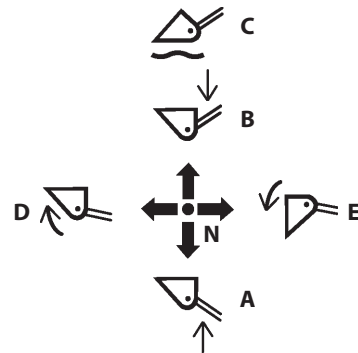

M4GB-01-074

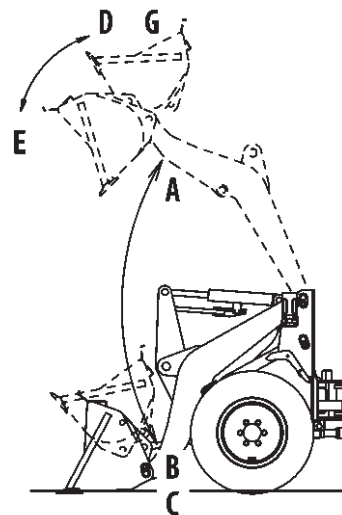

M4EJ-01-031

## OPERATOR'S STATION

### Lever Locks

**WARNING:** When locking the loader control lever and the auxiliary control lever (optional), securely shift lever locks (2) and (4) to the LOCK position. Unless lever locks (2), (4) are fully moved to the LOCK position, the control levers are not locked, possibly creating a hazardous situation.

Before leaving the operator's seat, be sure to stop the engine. Then, move lever locks (2), (4) to the LOCK position.

Always check to be sure that the lever locks are moved to the LOCK position before:

- Transporting the machine.
- Leaving the machine at the end of the shift.

Refer to section 5-2 for details.

Lever locks (2), (4) are provided to prevent the machine is unexpectedly operated even if the operator mistakenly comes in contact with loader control lever (1) or auxiliary control lever (3) (optional) when getting on or off the machine. When loader control lever (1) and auxiliary control lever (3) (optional) are placed to the UNLOCK position, the levers become operable.

**NOTE:** Auxiliary control lever (3) and lever lock (4) are optional.

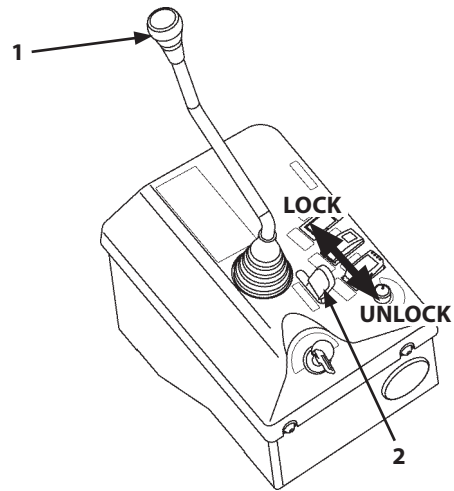

M4FG-01-059

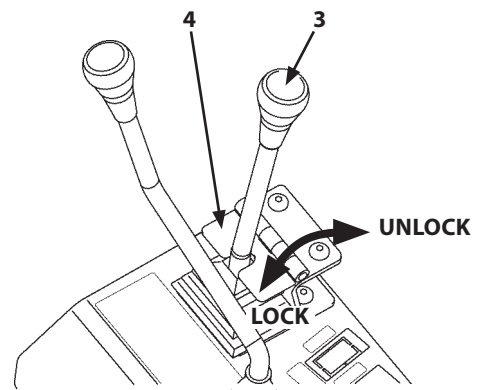

Auxiliary Control Lever (Optional) M4FG-01-024

## OPERATOR'S STATION

### Key Switch

**⚠ WARNING:** Before starting the engine, return the forward/reverse lever to neutral, apply the parking brake, and lock the loader control lever lock. Refer to the descriptions in the OPERATING THE ENGINE section for the detail information.

**⚠ WARNING:** Never turn key switch (6) OFF while traveling the machine. Failure in the electrical system and/or machine may result.

- 1- OFF (Engine Off)
- 2- ON (Engine On)
- 3- START (Engine Start)

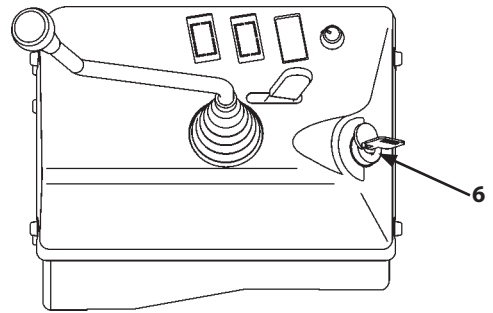

M4EK-01-013

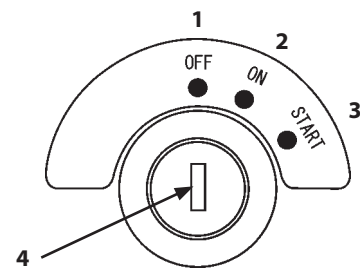

MNBC-01-013

# OPERATOR'S STATION

## Travel Mode Switch

Switch (1) is used to shift the travel speed stage. Select the position to match the desired travel/work mode.

**LOW (Work) Mode:**  
Travel speed is kept maintained to the first stage.  
Available travel speed range: 0 to 7.5 km/h

**AUTO (Travel) Mode:**  
Travel speed is automatically shifted within the range of the first to 2nd speed stage by operating the accelerator pedal.  
Available travel speed range: 0 to 15 km/h

Refer to the pages of "Driving the Machine" for more information.

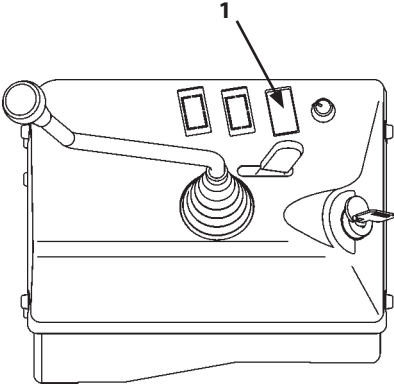

M4EK-01-013

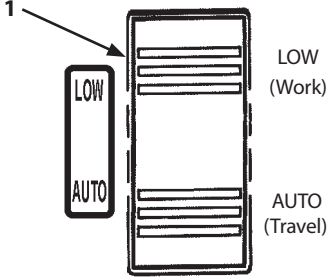

M4EJ-01-090



## OPERATOR'S STATION

### Air Conditioner (Optional) Operation

#### Components Name

- 1- Control Panel
- 2- Defroster Vent
- 3- Foot Vent
- 4- Rear Vent

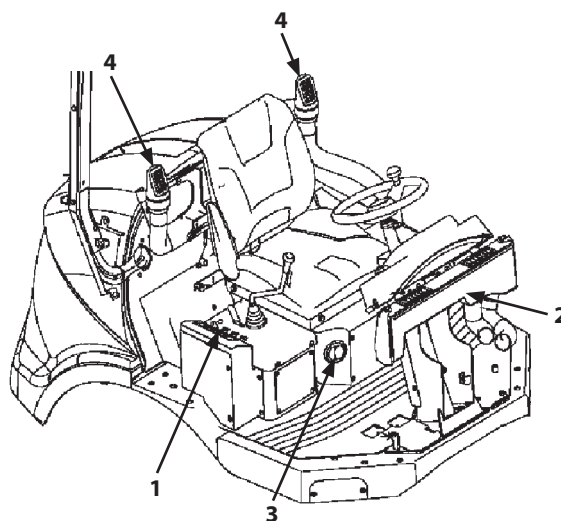

MNBB-01-006

#### Control Panel Arrangement

- 5- Liquid Crystal Panel
- 6- Air Conditioner Switch
- 7- Power Switch
- 8- Blower Switch
- 9- Temperature Control Switch

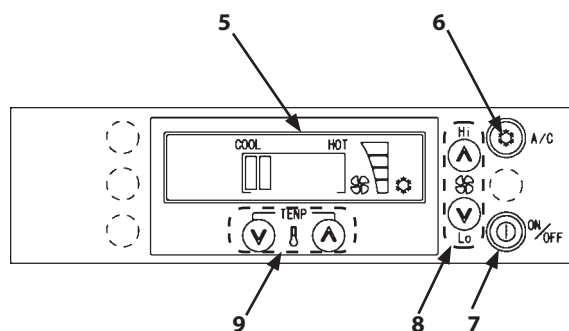

Control Panel

M4EK-AC-001

#### NOTE:

- Direction of airflow from foot vent (3) and rear vent (4) can be changed by adjusting the direction of the louvers. The louvers are opened or closed by hand.
- Both warm and cool air flows out of the same air vent.

## OPERATOR'S STATION

### Control Panel Switch Designation and Function

#### Power Switch (7)

Press power switch (7) to light the set indicators of the air temperature and the blower speed on liquid crystal panel (5). The blower will start running. Press power switch (7) again to stop the blower.

#### Blower Switch (8)

The airflow volume can be adjusted in 3 stages from "Lo" to "Hi". The airflow volume is indicated on the right side of liquid crystal panel (5).

- Increasing Airflow

*Each time the button with mark "∧" (Hi) at the top of blower switch (8) is pressed, airflow volume increases by one stage.*

- Decreasing Airflow

*Each time the button with mark "∨" (Lo) at the bottom of blower switch (8) is pressed, airflow volume decreases by one stage.*

#### Temperature Control Switch (9)

Airflow temperature is adjusted with this switch in 5 stages. Lightening position of the indicator segments between the COOL and HOT marks at the center of the liquid crystal panel shows the set temperature.

- Increasing Temperature

*Each time the button with mark "∧" on the right side of temperature control switch (9) is pressed, set temperature increases by one stage.*

- Decreasing Temperature

*Each time the button with mark "∨" on the left side of temperature control switch (9) is pressed, set temperature decreases by one stage.*

#### Air Conditioner Switch (6)

Press switch (6) to turn the air conditioner ON (Cooling and dehumidifying). The indicator located at the right most side of the liquid crystal panel will come ON. Press power switch (7) again to stop the air conditioner.



**NOTE:** *Even though air conditioner switch (6) is turned OFF, as long as power switch (7) is ON, the blower continues running.*

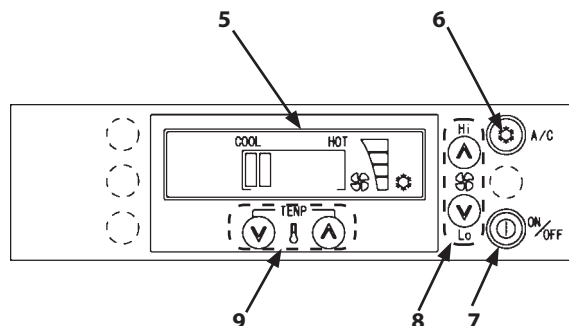

M4EK-AC-001

## OPERATOR'S STATION

### Tips for Optimal Air Conditioner Usage

#### For Rapid Cooling:

Temperature in the cab may rise over 80 °C (176 °F) when the machine is kept exposed to sunlight in the summer. For rapid cooling, open the door to ventilate hot air in the cab first. After starting the engine, set the airflow temperature to the lowest level with temperature control switch (9).

After running the engine at a slightly faster than 1200 min<sup>-1</sup> (rpm) for 2 to 3 minutes, close the door. When temperature in the cab starts cooling, set the proper temperature with temperature control switch (9).

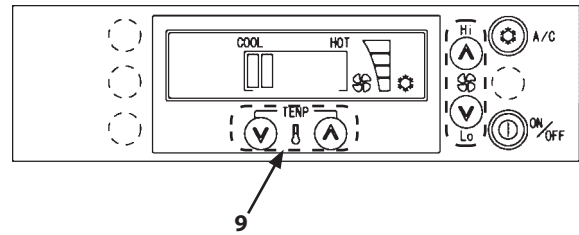

M4EK-AC-001

#### When Windows Become Clouded:

If the insides of the windowpanes become clouded due to high humidity in the cab during rainy weather, operate the air conditioner to clear cloud on the windowpanes. When the atmosphere is very damp, if the air conditioner is operated at too low a temperature, the outside of the windowpanes may become clouded. If this happens, turn off the air conditioner to adjust the temperature in the cab.

#### Maintenance of the Air Conditioner Being Not in Use:

To protect each part of the compressor from a lack of lubricant, operate the air conditioner at least once a month for several minutes with the engine running at a slow speed even when the air conditioner is not used. When temperature in the cab is lower than 15 °C (59 °F), the air conditioner may not operate as a cooler. If this happens, warm the cab temperature using the heater.

**IMPORTANT:** When performing running-in operation of the air conditioner, run the engine at slow speed. Keep open fire away from the control panel. Refer to the item "CLEAN AND REPLACE CIRCULATION AIR FILTER FOR AIR CONDITIONER" in the Maintenance section for the filter maintenance practices.

## OPERATOR'S STATION

### Adjusting the Operator's Seat (Reclining Type)

**CAUTION:** Adjust the seat to a position that allows pedals, levers and switches to be operated easily. Adjust the seat while the machine is parked.

#### Name of Components

- 1- Slide Lever
- 2- Backrest Lever

#### 1. Fore-Aft Adjustment

The seat can be adjusted forward or backward. Lift up slide lever (2) and slide the seat to the desired position; it can be adjusted in 20 mm increments across a range of 240 mm. Release the lever when in the desired position and then make sure the seat is locked and does not move.

#### 2. Backrest Adjustment

The angle of the backrest can be adjusted in 2.5° increments, from 7.5° forward to 30° backward (cab-equipped machines, 20°) by lifting backrest lever (3). Release backrest adjustment lever (3) when in the desired position and then make sure the backseat is locked and does not move.

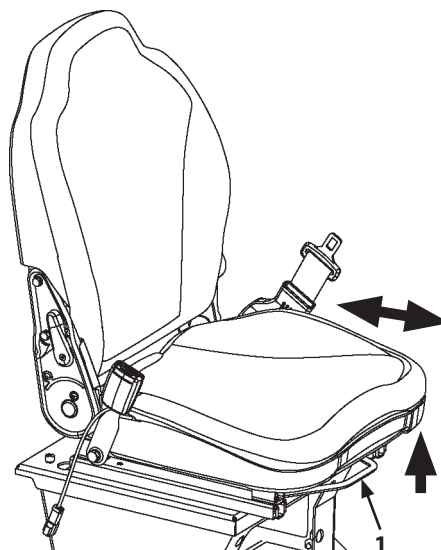

MNBC-01-014

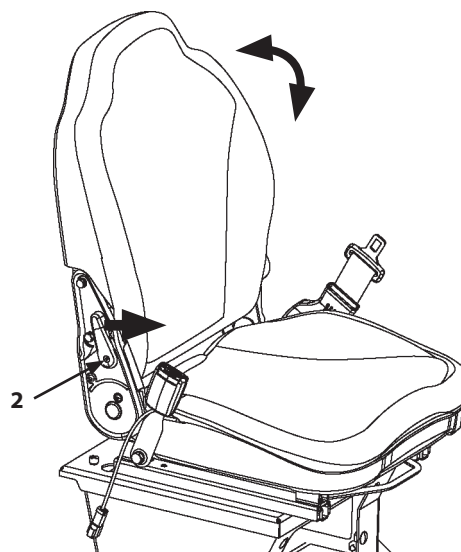

MNBC-01-014

## OPERATOR'S STATION

### Seat Back Pocket

A pocket is provided on the back of the operator's seat. Keep the user's manual and other information in the pocket.

 **NOTE:** It is not completely waterproof. If necessary, use a plastic bag or the like to keep it dry.

1. To open the cover of the seat, tilt the seat back forward, insert the key and turn it clockwise to unlock it.
2. Perform step 1 in reverse to close the cover.

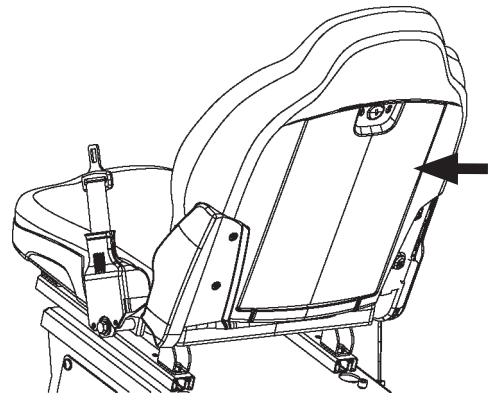

MNBC-01-015

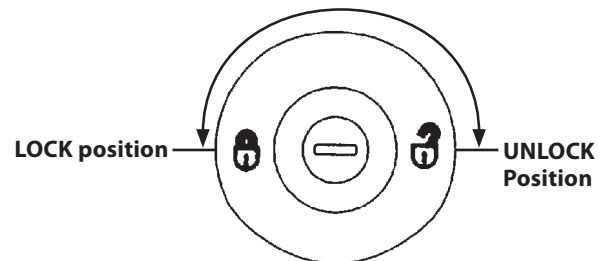
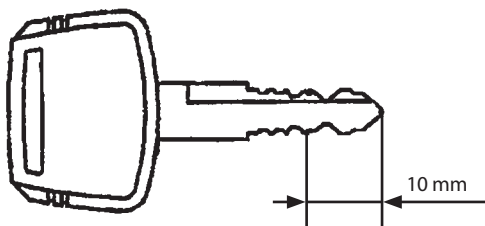

MNBC-01-016

 **NOTE:** Only the end of the key can be inserted, about 10 mm.

## OPERATOR'S STATION

### Fuse Box

**IMPORTANT:** If a fuse blows, turn the key switch OFF and investigate the problem with the power off. Replace the fuse with a new one.

**Disconnect the minus terminal of the battery before replacing a slow-blow fuse.**

The purpose of fuses is to provide a safety valve for the electrical system and prevent excessive current from flowing through its circuits.

Remove the cover of fuse box (1), which is behind and to the right of the operator's seat, to access the fuses.

Open the hood to access slow blow fuses (2) and (3), to the front of the battery.

The capacity varies with the circuit concerned, so replace with a fuse of the rated capacity.

When checking the fuses, check them in the order of fuse box (1), slow blow fuse (2) and (3).

Slow Blow Fuse (2): 100 A×2

Slow Blow Fuse (3): 65 A

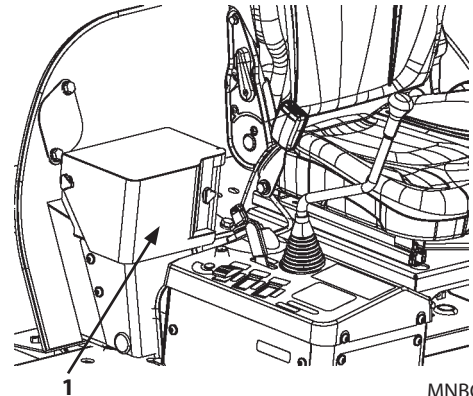

MNBC-01-017

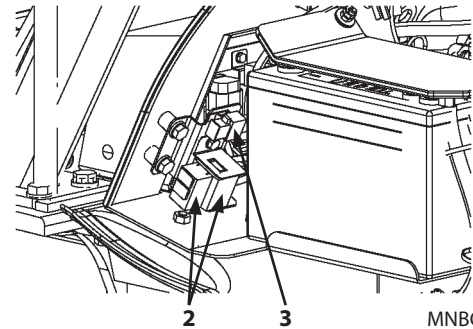

MNBC-01-018

## OPERATOR'S STATION

### Fuse Box

No.	Amperes	Circuit
1	15 A	Headlight
2	-	(OP)
3	15 A	Hazard Lamp (OP)
4	5 A	Controller, Electronic Key (1) (OP), Tachograph (1) (OP)
5	30 A	Engine (1), ECM
6	5 A	Cab Light (Cab)
7	5 A	Engine (3), Airflow Sensor
8	15 A	Engine (2), EGR, Fuel Pump, Oil Separator
9	10 A	Key On, Electronic Key (2) (OP), Tachograph (2) (OP)
10	10 A	Discharge Warning Indicator, Alternator
11	(10 A)	Heater (Canopy) (FG Canopy) (OP)
12	(10 A)	Rear Work Light (Canopy) (OP)
13	(10 A)	Rotating Light, Alarm Light (Canopy) (OP)
14	5 A	Clearance Light, License Plate Light
15	10 A	Direction Indicator
16	15 A	Parking Brake, Backup Light, Backup Buzzer, HST Control, Travel Mode Switch (OP)
17	15 A	Bucket Auto Leveler
18	15 A	Horn, Brake Light
19	10 A	Instrument Light
20	-	-

 NOTE: Fuses with parentheses in the Amperes column are optional.

### Fuse Box (Cab-Equipped Machines) (Optional)

No.	Amperes	Circuit
1	30 A	Wiper Motor (Front) Washer Tank (Front)
2	20 A	Wiper Motor (Rear) Washer Tank (Rear)
3	10 A	Radio (OP)
4	15 A	Front Work Light (Cab) FG Canopy)
5	10 A	Rear Work Light (Cab) (OP)
6	(10 A, 30 A)	Heater (10 A), AC (30 A) (OP)
7	(10 A)	A/C (2) (OP)
8	(10 A)	Rotating Light, Alarm Light (Cab) (FG Canopy) (OP)
9	-	(OP)
10	-	-

 NOTE: Fuses with parentheses in the Amperes column are optional.

# OPERATOR'S STATION

## Rops Cab (Optional)

ROPS Cab (1) is a optional equipments.

- 1- ROPS Cab
- 2- Room Light
- 3- Room Rear View Mirror
- 4- Sun Visor

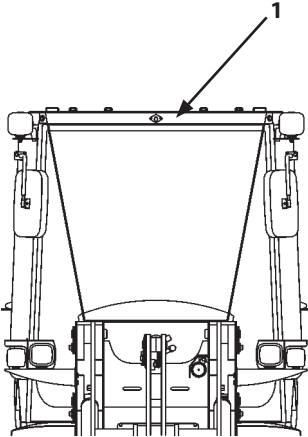

M4EK-01-029

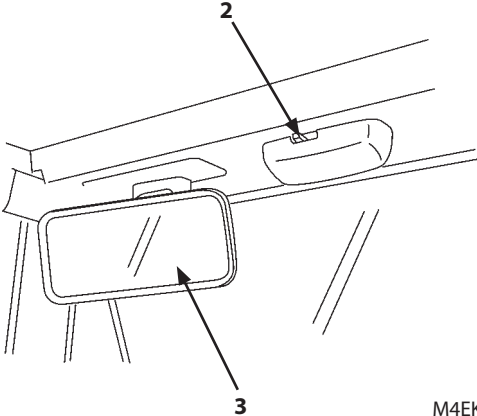

M4EK-01-030

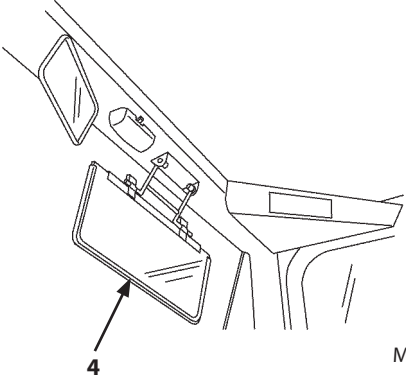

M4FG-01-055



# OPERATOR'S STATION

- 5- Radio
- 6- Cab Switch Panel (Optional)
- 7- Drink Holder
- 8- Speaker
- 9- Coat Hook

 **NOTE:** The radio and speakers are locally procured optional equipment. The illustrations are example.

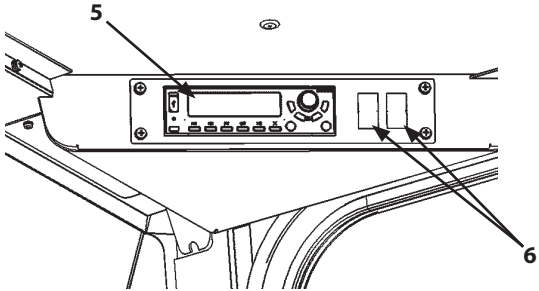

MNCH-01-551

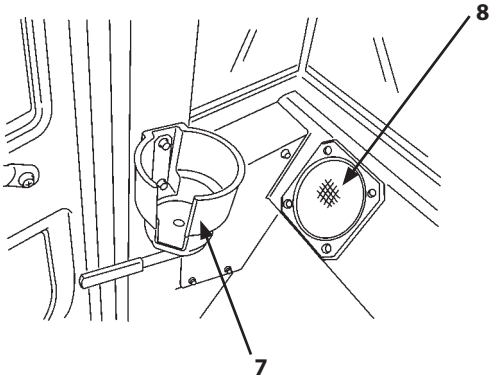

M4EK-01-032

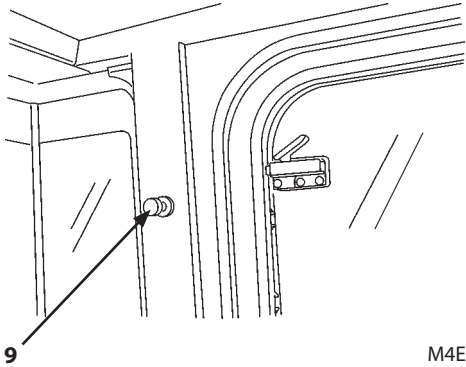

M4EK-01-033

## OPERATOR'S STATION

### Room Light

Press switch (1) to turn the room light ON. The room light switch has three operation positions.

- ON: The light (2) comes and stays ON.
- Neutral: The light (2) goes OFF.
- DOOR: When the cab door is opened, the light (2) comes ON. When closed, the light (2) goes OFF.

 **NOTE:** "DOOR" position of cab light (1) activates only when the left side cab door is opened.

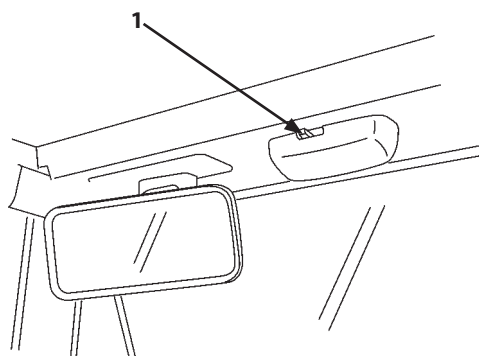

M4EK-01-030

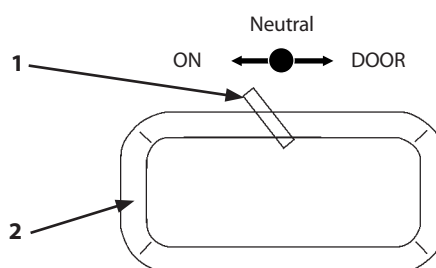

M4EK-01-034A

### Sun Visor

Pull the sun visor down when blocking strong sun light radiation from the cab top side.

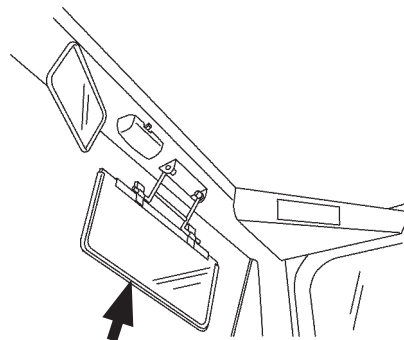

M4FG-01-055

### Drink Holder

**IMPORTANT:** Be sure to put a plug or cap on a drink bottle when placing it on the drink bottle holder.

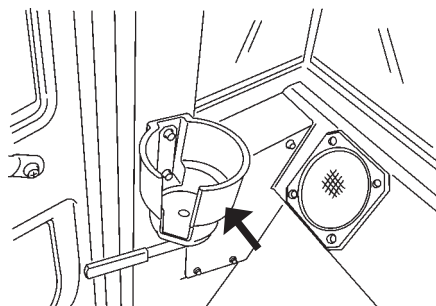

M4EK-01-032

## OPERATOR'S STATION

### Emergency Evacuation Hammer

In case of emergency in which the cab door cannot be opened, break the glass of a window with hammer (1) to escape.

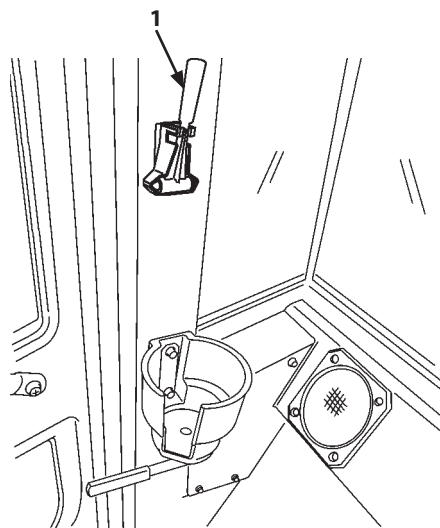

MNBB-01-002

### Coat Hook

Use coat hook (2) for hanging up clothing, like jackets and hats.

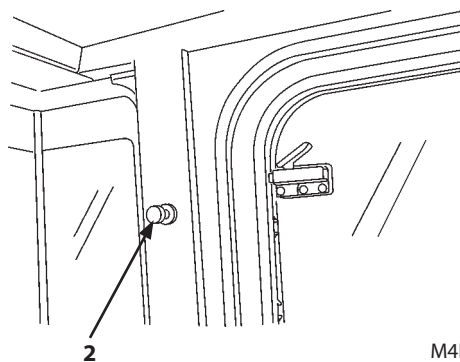

M4EK-01-033

### Rearview Mirror

**⚠ WARNING: Do not rely solely on rearview mirror (3) when backing up. Use the rearview mirror as an aid and look behind when backing up.**

Sit in the operator's seat and adjust it so the rear of the vehicle can be visually checked. Always keep it clean.

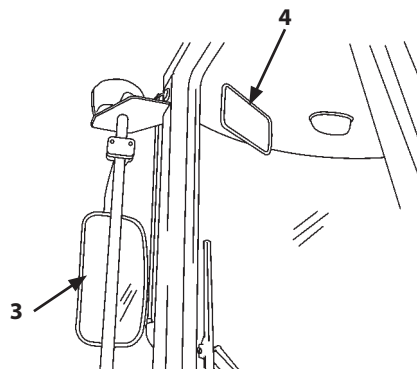

M4EK-01-035

### Rearview Mirror

Always keep rearview mirror (4) clean.

# OPERATOR'S STATION

## Cab Switch Panel (Optional)

- 1- Auxiliary
- 2- Auxiliary

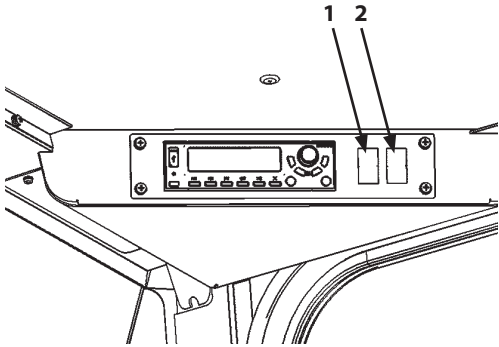

MNCH-01-551

## OPERATOR'S STATION

---

### Cab Door

**⚠ CAUTION:** Securely close the door. If the door is unexpectedly opened, a hazardous situation may be created. Before leaving the operator's seat, fully open the cab door and lock the door in position.

- 1- Door Lock
- 2- Door Open/Close Lever

**📌 NOTE:** Unless the cab door is securely closed, the room light switch keeps the room light ON. Securely close the cab door.

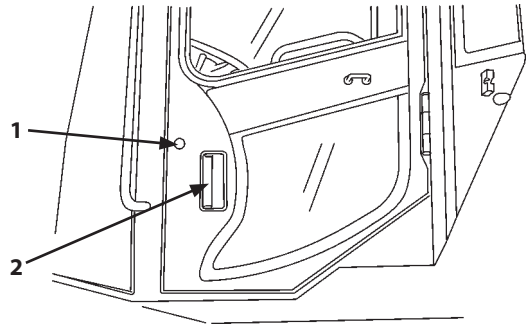

M4EK-01-045

## OPERATOR'S STATION

### Door Lock Knob

**CAUTION:** After closing the door, always check that the door lock is securely engaged.

Depress door lock knob (5) to engage the door lock.

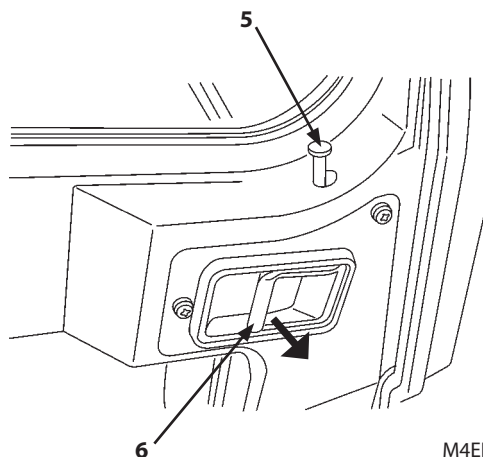

M4EK-01-046

### Door Open/Close Lever

When opening the door, while lifting door lock knob (5), pull lever (6) to disengage the door lock.

### Window Open/Close Levers

When window open/close levers (7) on both sides are simultaneously pressed, the window is unlocked, allowing the windowpanes to move. When window open/close levers (7) are released, stoppers are engaged in the nearest steps so that the window is locked in that position.

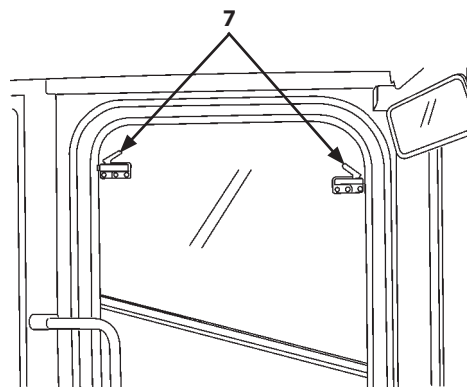

M4EK-01-047

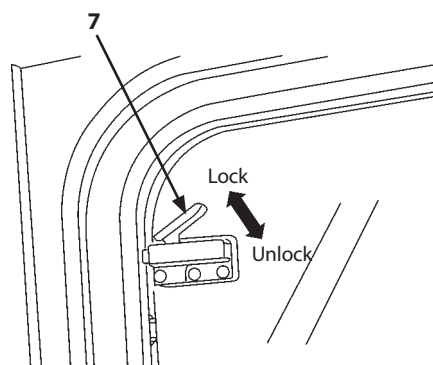

M4EK-01-048

# OPERATOR'S STATION

### When Fully Opening the Door

Push the door toward the outside of the cab to fully open the door (180°).

### Door Lock Disengage Lever

**CAUTION:** When keeping the door open, open the door until latch (8) on the cab securely locks the door. When disengaging the door lock, push door lock disengage lever (9) or (10) downward.

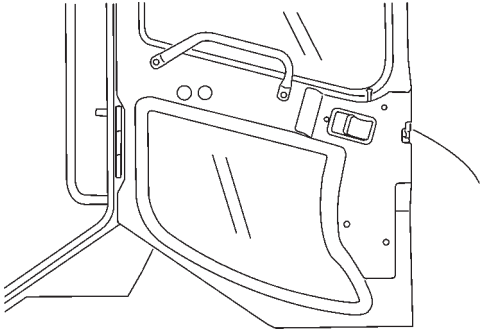

M4EK-01-049

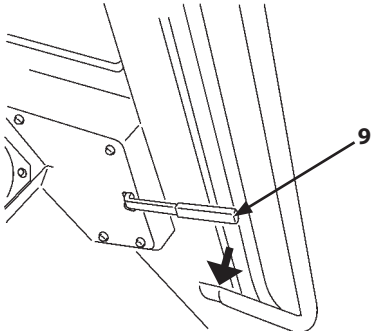

Left Door

M4EK-01-050

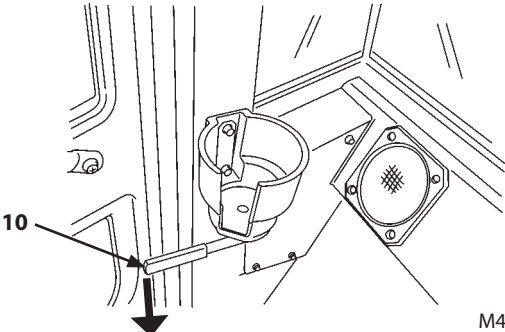

Right Door

M4EK-01-032

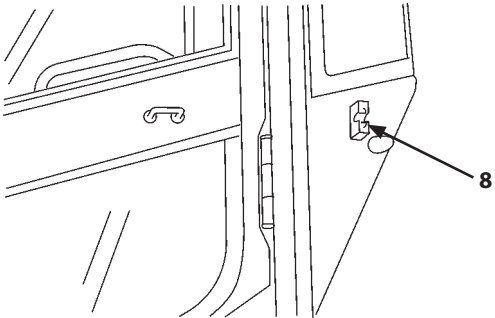

M4EK-01-051

## OPERATOR'S STATION

### Articulation Lock Bar

**⚠ WARNING:** Before servicing or transporting the machine, be sure to engage lock bar (1). Before driving the machine, be sure to disengage the lock bar (1) from the front frame (3) and fasten the lock bar to the rear frame with pin (1) and lock pin (2).

Locks the front and rear frames to prevent articulation between the front and rear frames when servicing or transporting the machine.

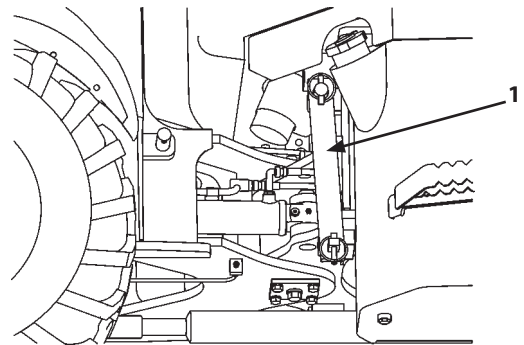

M4EK-01-052

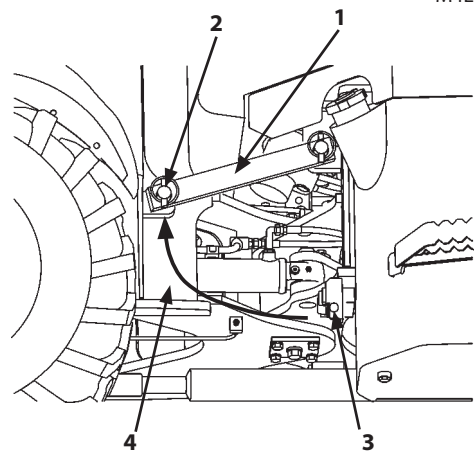

M4EK-01-053

### Towing Pin

**⚠ WARNING:** Since towing is potentially hazardous, only tow when there is an emergency situation in which the loader must be moved in this manner.

**⚠ CAUTION:** Be aware of the following points:

- Be sure to use only the equipped pin (5).
- Be sure to inserting the towing pin completely.
- Slowly drive the machine while towing.

When towing another machine or fastening the machine on a trailer deck for transportation, use pin (5) equipped on the back end of the machine.

Available towing forces are as follows. To prevent excessive wear of tires, avoid towing operation requiring more than the available towing force.

33.4 kN (3400 kgf)

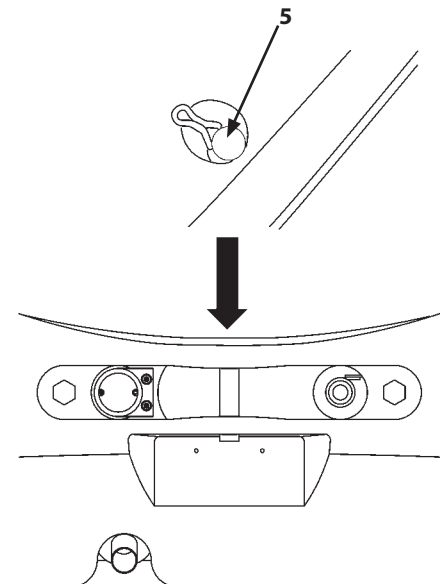

M4EK-01-054



## OPERATOR'S STATION

### Engine Hood

- ⚠ WARNING:** Open/close engine hood (1) only when the engine is stopped. Failure to do so may cause personal injury or death due to entanglement into the engine fan.
- Before using the machine, check that engine hood (1) does not open.**

#### Opening/Closing Engine Hood

- Canopy equipped machine
  1. Press lock key (2) to unlock engine hood (1).
  2. While supporting engine hood (1), slowly raise and open engine hood (1).
  3. When closing engine hood (1), slowly lower and close engine hood (1) while supporting engine hood (1). Be sure to close engine hood (1) until it latches (a click sound is heard).

**✎ NOTE:** Engine hood (1) can be locked with a key.

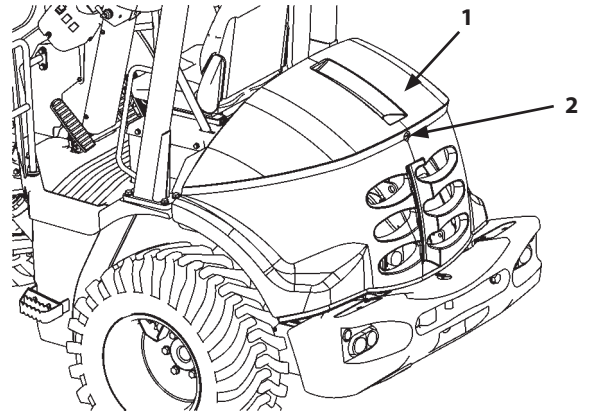

M4ER-01-004

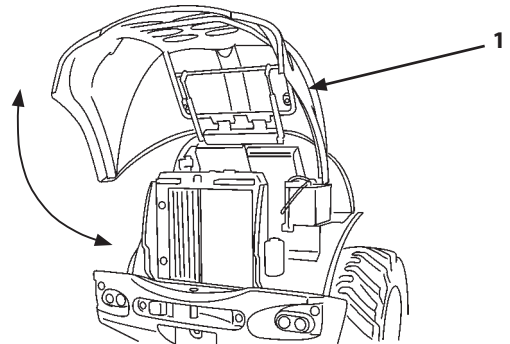

M4EK-01-056

### Steps

- ⚠ WARNING:** When getting on and off the machine, always maintain at least three points of contact. Getting on and off the machine with less than three support points may cause you to slip, possibly resulting in a falling accident.

Although the steps are provided on both sides of the machine, mainly use the steps on the left side. The control levers are located on the right side, obstructing easy access.

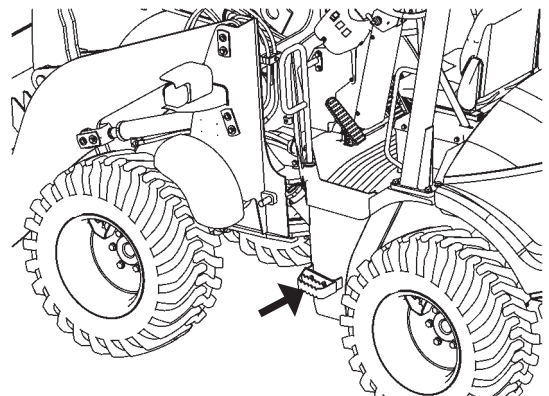

M4ER-01-005

# OPERATOR'S STATION

## Vandal-Resistant Devices

A lock key can be installed to fuel tank cap (1) and engine hood (2).

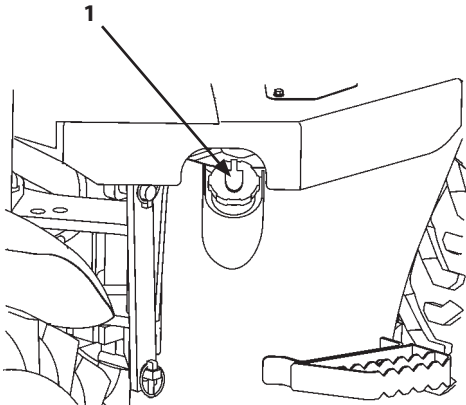

M4EK-01-058

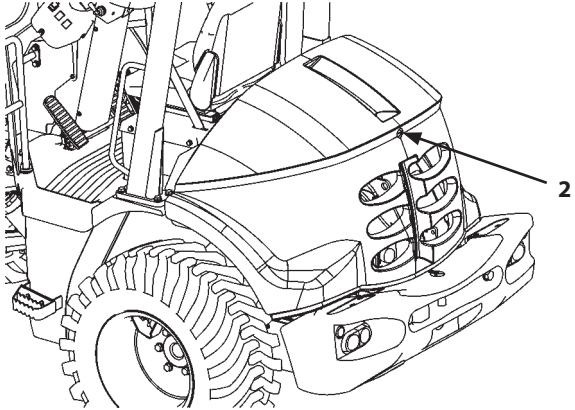

M4ER-01-004

## OPERATOR'S STATION

### Radio Unit (CAB) (Optional)

#### Control Panel

- 1- POWER button  
Turns the device ON/OFF.
- 2- SRC button  
Switches the source  
(FM1→FM2→AM→Bluetooth®→USB).
- 3- Search button  
Makes auto presets (FM/AM).
- 4- Return button  
Returns to the previous screen while setting operation.
- 5- Hands-Free button  
Receives mobile phone signal. Makes a redial call.
- 6- Rotary switch  
Adjust the volume.  
Switches between menu items and makes various settings.
- 7- SEEK BAND+/SEEK BAND- buttons  
Adjusts radio frequency.
- 8- PRESET buttons ([1] to [6])  
Calls up/registers preset frequencies.  
Operates the connected Bluetooth®/USB device.
- 9- MIC  
Microphone for hands-free operation.
- 10- USB port  
Connect a USB device.
- 11- LCD  
Refer to the following page.
- 12- Power Connector  
Power inlet and machine information input.
- 13- Antenna Port (for Analog Radio)  
Connect the antenna to receive AM/FM radio.

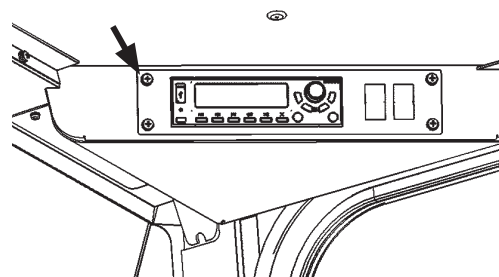

MNCH-01-551

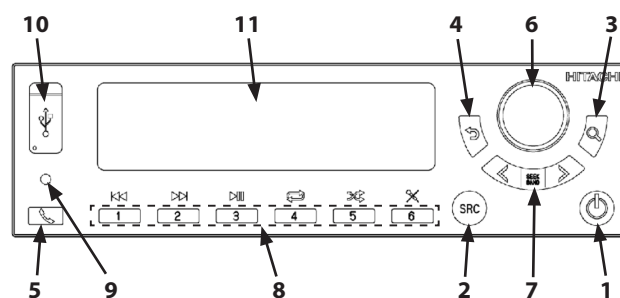

MNUD-01-402

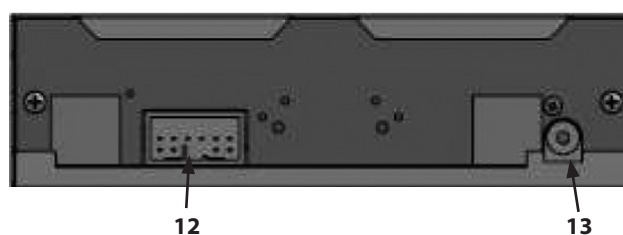

Rear View

MPTC-01-088

## OPERATOR'S STATION

### LCD Display

- 1- Information section  
Indicates the source name, frequency, service name, etc. in characters and/or numbers.
- 2- Source label  
Indicates the selected source name.
- 3- ST label  
Lights to indicate stereo reception when FM are selected.
- 4- USB label  
Lights when a USB device is connected.
- 5- Bluetooth® label  
Lights when connected to a Bluetooth® compatible device.
- 6- Clock  
Current time in 24 h format.
- 7- REPEAT label  
Lights when Bluetooth®/USB device is playing in repeat mode.
- 8- RANDOM label  
Lights when Bluetooth®/USB device is playing in random mode.
- 9- Folder No.  
Indicates the USB memory folder No.
- 10- Track No.  
Indicates the USB memory track No.
- 11- Menu/List title  
Indicates the title of the selected menu, source, program type.
- 12- List No.  
Indicates the selected list number among total selections.
- 13- Volume display  
Indicates the volume of currently selected source.

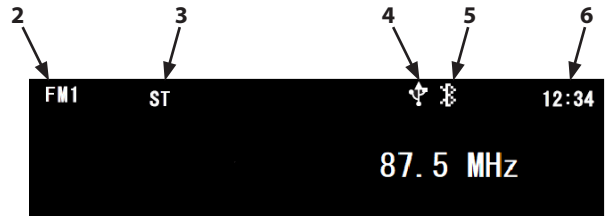

MNUD-01-448

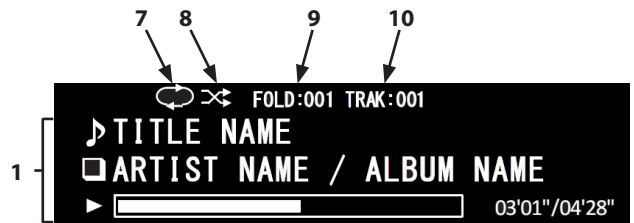

MNUD-01-404



MNUD-01-406

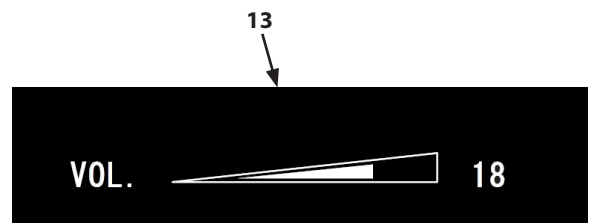

MNUD-01-405

## OPERATOR'S STATION

### Basic Operation

#### Turn ON the device

When the machine starter key is set to ON or ACC, the previously selected source is displayed on LCD (2). If the LCD displays nothing, press power button (1). The previously selected source appears on the LCD.

 **NOTE:** When the starter key is turned to OFF when the radio unit is in the standby mode, the radio unit starts up in the standby mode when the key is turned to ON or ACC. Refer to "Turn OFF the device" for the standby mode.

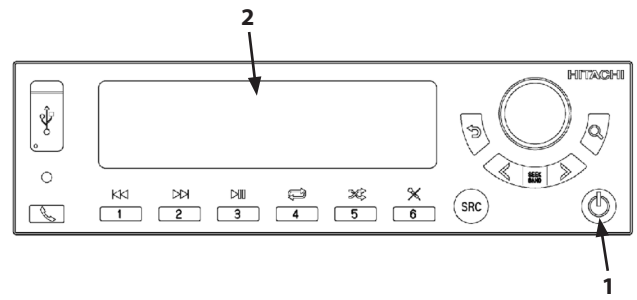

MNUD-01-402

#### Turn OFF the device

When the machine starter key is set to ON or ACC, the pressing power button (1) turns off the LCD. The power button (1) remains lit on (standby mode).

When the machine starter key is set to OFF with the radio unit is powered on, power button (1) and LCD (2) are both turned off.

# OPERATOR'S STATION

## Selecting Source

Long depressing SRC button (1) displays the source selection screen (4).



MNUD-01-450

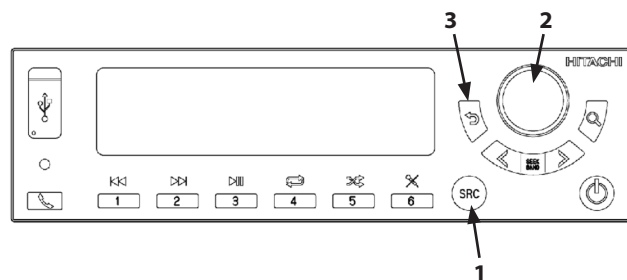

MNUD-01-402

- Rotate rotary switch (2) to highlight a desired source (FM1↔FM2↔AM↔Bluetooth®↔USB↔SETTING↔FM1).
- Press rotary switch (2) while selecting a source to display its sub-sources.
- Pressing SRC button (1) on each source screen moves to the screen to the next source screen (FM1→FM2→AM→Bluetooth®→USB→FM1).

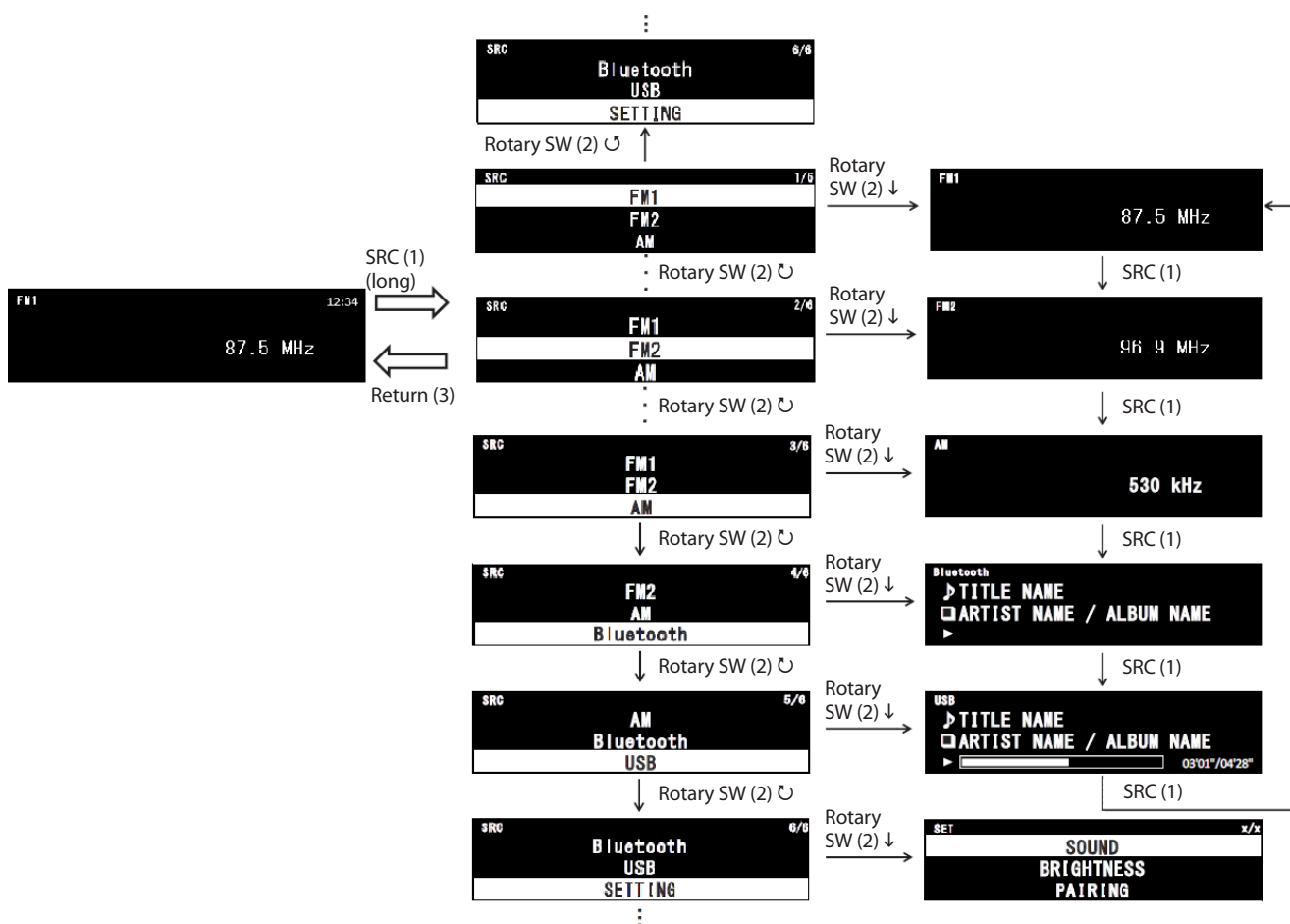

MNUD-01-449US

# OPERATOR'S STATION

**Volume Control**

The volume control can be done individually for each source and for hands-free calling.

Rotating rotary switch (1) clockwise increases the volume. Rotating rotary switch (1) counterclockwise decreases the volume.

The volume level is selected between 0 (mute) and 32.

 **NOTE:** The screen returns to the source screen when no operation is made for 3 seconds.

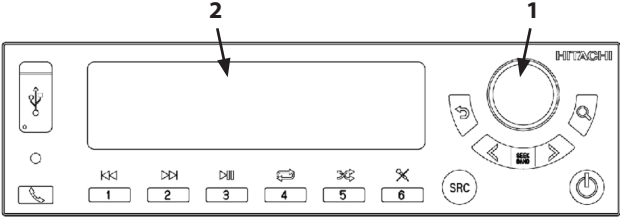

MNUD-01-402

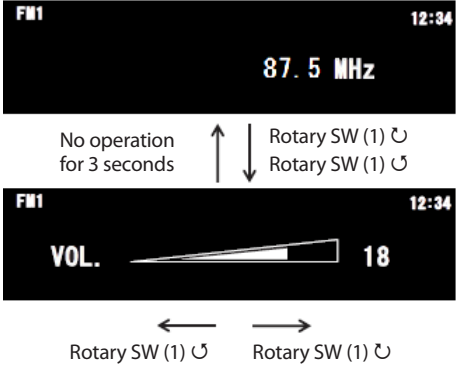

MNUD-01-416

## OPERATOR'S STATION

---

### About Trademark

The Bluetooth® wordmark and logo are registered trademarks owned by Bluetooth SIG, Inc., and Scribble Design Inc. uses these marks under license. Other trademarks and trade names belong to their respective owners.

### CAUTION:

- **Do not operate the radio or other audio equipment while driving or working.**
- **The speaker volume may vary depending on the source, radio, USB audio input, Bluetooth® audio or handsfree phone. Adjust to an appropriate volume, such as by changing the volume of the Bluetooth® compatible device.**

**IMPORTANT:** This device cannot connect to more than 1 Bluetooth® compatible device at a time.



## OPERATOR'S STATION

### FM/AM Radio Operation

**CAUTION:** Refrain from listening to the radio while operating the machine.

Receives both FM and AM radio.

**NOTE:** The only difference between FM1 and FM2 is the grouping of preset numbers; the function is the same.

### Control Panel

- 1- POWER button  
Turns the radio ON/OFF.
- 2- SRC button  
Switches the source  
(FM1→FM2→AM→Bluetooth®→USB).
- 3- Search button  
FM/AM auto presets.
- 4- Rotary switch  
Adjust the volume.
- 5- SEEK BAND+/SEEK BAND- buttons  
Adjusts radio frequency.
- 6- PRESET buttons ([1] to [6])  
Calls up/registers preset frequencies.

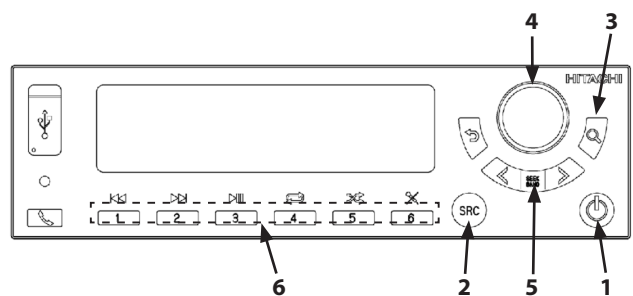

MNUD-01-402

## OPERATOR'S STATION

### Station Presetting Procedure

1. Select the desired station. Refer to the following page "Tuning Procedure".
2. Press and hold a desired PRESET button (1) for more than 1 second. The current station is preset to the selected number of button. When the station is preset, the "PRESET-x" blinks for 3 seconds on LCD (5). Once the presetting is complete for a PRESET button, the radio will be tuned to the preset station when the PRESET button is pressed.
3. To change the preset station, follow the same steps 1 and 2.

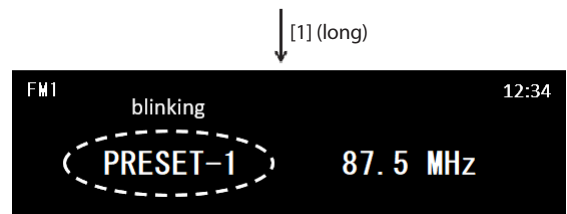
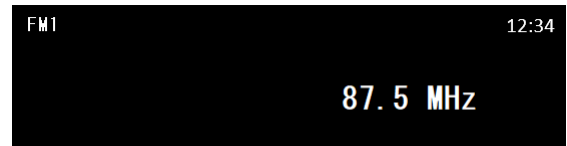
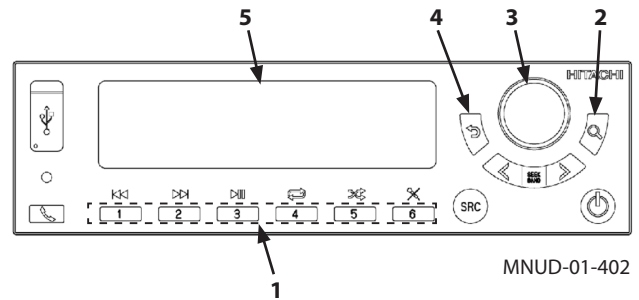

MNUD-01-411US

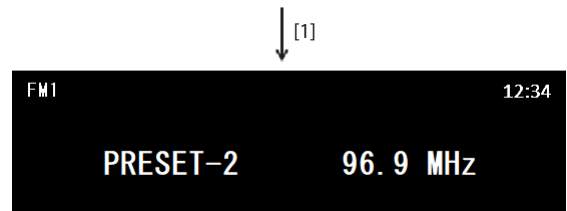
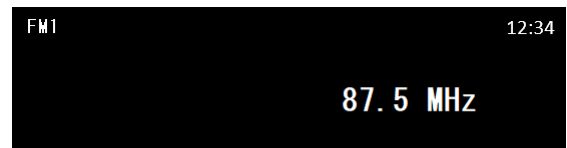

MNUD-01-412US

### Calling up Preset Stations

Press any of PRESET buttons (1) to tune and receive the registered station frequency. "PRESET-x" with the selected number is displayed on LCD (5).

#### Factory Default Setting

PRESET	AM (kHz)	FM (MHz)
1	530	87.5
2	910	96.9
3	1000	97.9
4	1100	98.9
5	1540	106.9
6	1710	107.9

**IMPORTANT: The PRESET data will not be erased even disconnected from the battery. The changed PRESET data is stored in the internal memory at ACC OFF, however, if ACC and battery are both OFF at the same time, the changed data is not stored.**

### Auto-Preset Function

By keep depressing search button (2), up to 6 stations with best reception can be automatically registered to PRESET buttons (1) (auto-preset function).

"AUTO PRESET" blinks on LCD (5) while auto-preset is running.

The station frequency is registered from No. 1 through No. 6 in frequency order.



MNUD-01-413

## OPERATOR'S STATION

### Tuning Procedure

- Automatic Search Function (Auto Seek)

Press and hold SEEK BAND+ button (1) and/or SEEK BAND- button (2) for more than half a second, then release. Automatic search for the station starts to run and stops when a station is received.

Press SEEK BAND+ button (1) to search a higher frequency.  
Press SEEK BAND- button (2) to search a lower frequency.

If no stations with good reception can be found after searching the entire band, the radio continues searching. Press either SEEK BAND button (1)(2) to cancel the searching operation.

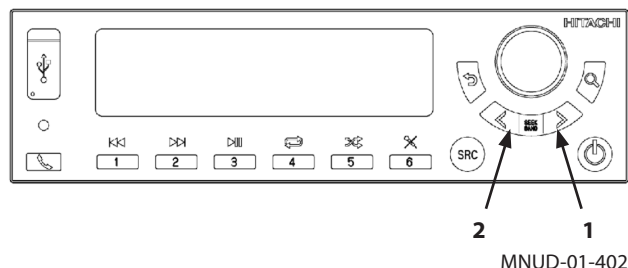

**NOTE:** If the receiving radio waves are weak, i. e. such as when the machine is located between high rising buildings, etc., use the manual tuning procedure to select the desired station.

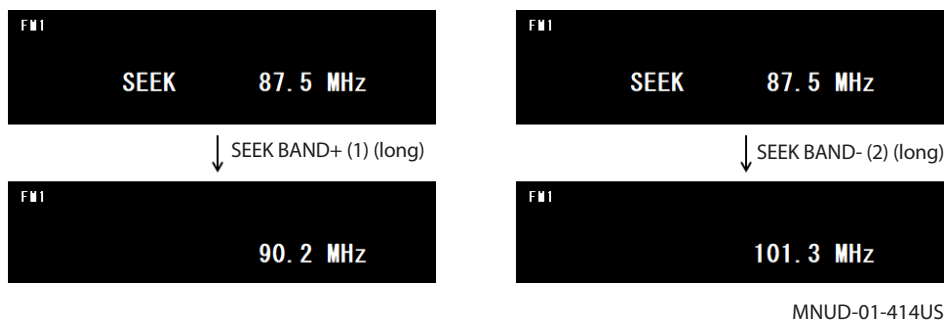

- Manual Tuning Procedure (Manual Seek)

Press SEEK BAND+ button (1) and/or SEEK BAND- button (2) until the desired station is reached. Each time SEEK BAND buttons (1)(2) is pressed, the frequency changes at an interval.

Press SEEK BAND+ button (1) to increase the frequency.  
Press SEEK BAND- button (2) to decrease the frequency.

**NOTE:** AM frequency interval: 10 kHz  
FM frequency interval: 0.2 MHz



## OPERATOR'S STATION

### Bluetooth® Input

**IMPORTANT:** A special Bluetooth® unit is necessary to use this function.

#### Specified Characteristics

Frequency	2.4 GHz
Version	3.0
Class	2
Applicable profile	A2DP, AVRCP, HFP, HSP, SPP
Max. Number of Pairing Device	16

The audio files can be played via Bluetooth® connection with a cell phone or Bluetooth® audio playback device.

 **NOTE:** Refer to page 1-73 for pairing.  
Refer to page 1-75 for device connection.

The track title, artist name, album name are displayed on LCD (3).

If they are too long to display in one line, separately displayed as shown to the right. Press return button (4) to change the screens.

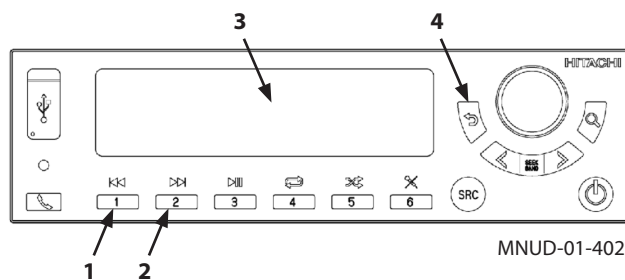

MNUD-01-402

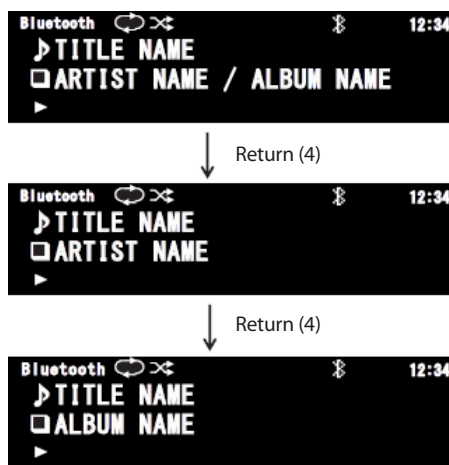

MNUD-01-418

# OPERATOR'S STATION

## Change Track

Press [2] button (2) to start playing the next track.

Press [1] button (1) to play the previous track.  
According to the connected device setting, pressing [1] button (1) returns to the top of the currently playing track.  
Then press [1] again to play the previous track.

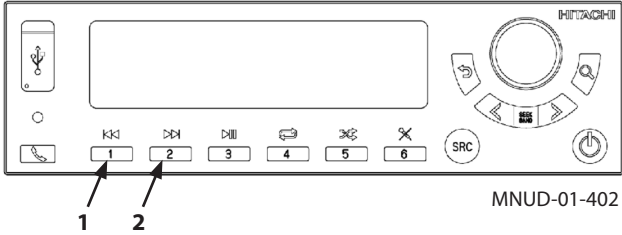

## Fast-forward/Fast-rewind

While playing a track, depressing [2] button (2) fast-forwards the track until releasing [2] button. Fast-forward label (3) is displayed while depressing [2] button.

While playing a track, depressing [1] button (1) fast-rewinds the track until releasing [1] button. Fast-rewind label (4) is displayed while depressing [1] button.

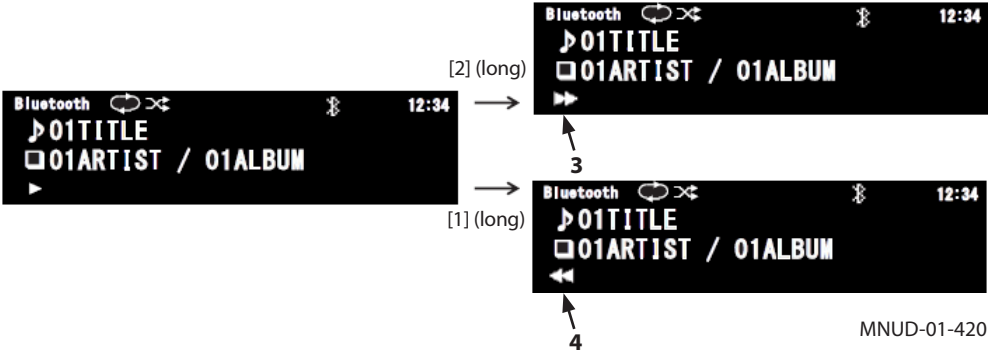

## OPERATOR'S STATION

### Pause/Playback

Pressing [3] button (1) while playing a track pauses playback. PAUSE label (4) is displayed.

Pressing [3] button (1) again starts playing from where it was paused.

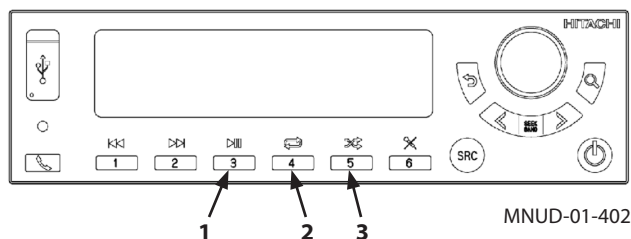

MNUD-01-402



4

MNUD-01-419

### Repeat

Pressing [4] button (2) plays the same track repeatedly. REPEAT label (5) is displayed.

Pressing [4] button (2) again plays the same album or folder repeatedly. REPEAT label (6) is displayed.

 **NOTE:** This function is not applicable depending on the connected device.

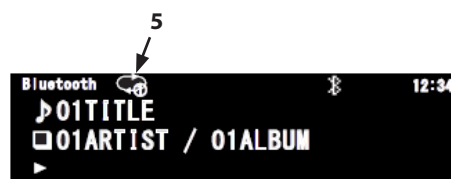

MNUD-01-421

### Random

Pressing [5] button (3) plays the tracks in random order. RANDOM label (7) is displayed.

 **NOTE:** This function is not applicable depending on the connected device.

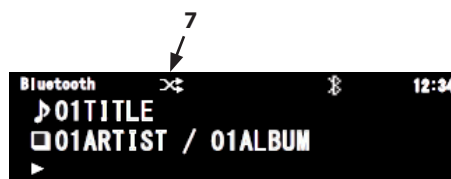

MNUD-01-422

## OPERATOR'S STATION

### Hands-free Call

**IMPORTANT:** A special Bluetooth® connected cellphone is necessary to use this function.

Allows handsfree conversations when using a Bluetooth® (HFP protocol) compatible cellphone.

- Making a Call

When calling from the cellphone, "DIALING" is displayed on LCD (2) and the sound from dialing is heard from the speakers. The voice of the other end party is heard from the speakers when connected.

- Redial

Regardless of the band (or operation), long pressing Hands-Free button (1) dials to the last incoming dial number since the ACC was turned ON.

"DIALING" is displayed on LCD (2) and the sound from dialing is heard from the speakers. The voice of the other end party is heard from the speakers when connected. Pressing Hands-Free button (1) during talk ends call.

 **NOTE:** The redial function may not work if the length of the previous incoming call was short.

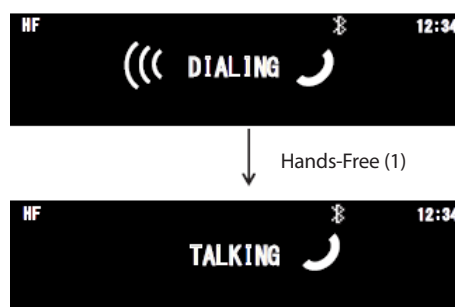
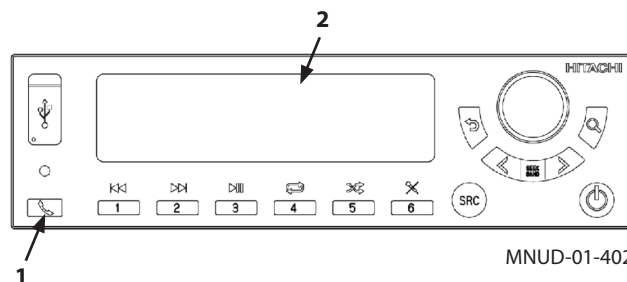

MNUD-01-423

## OPERATOR'S STATION

- Incoming Call

When a call comes in, "CALLING" is displayed on LCD (2), regardless of the band (or operation), and the speaker rings with the call.

Press Hands-Free button (1) to answer.

 **NOTE:**

- Even if the source of the radio unit is OFF when a call comes in, the source automatically turns ON, and "CALLING" is displayed and the speaker sounds ringing.
- According to the setting, auto-answer to the incoming call is possible. Refer to page 1-74 for the setting procedure.

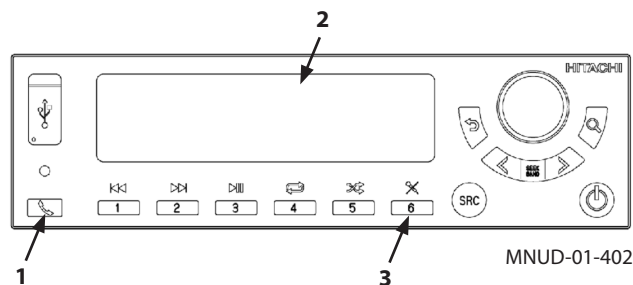

- Reject call

When a call comes in, keep depressing Hands-Free button (1) rejects and ends the call. The radio returns to the band (or operation) before the call.

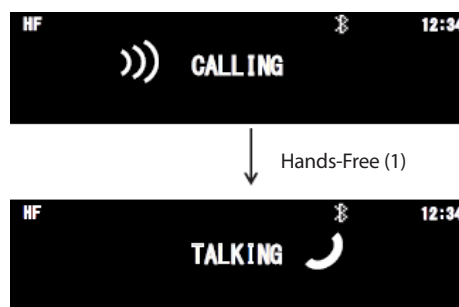

- MIC Mute

A microphone for hands-free talking is built-in the front panel of the radio unit.

Pressing [6] button (3) turns ON/OFF this microphone.

When the microphone is OFF, MUTE label (4) is displayed.

 **NOTE:** MIC mute is canceled at each call.

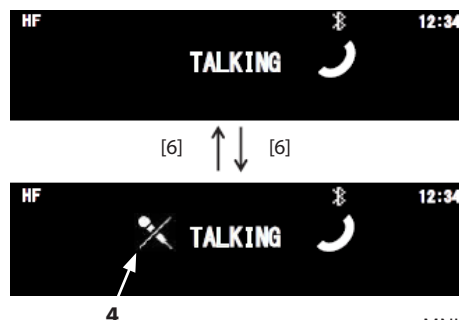



## OPERATOR'S STATION

### USB Device Input

Plays audio files via USB connection with a cell phone or audio playback device.

#### USB Specifications

Rated Current	Max. 2 A
Output Voltage	5.00 V when USB cable is not connected.
Applicable Data Format	MP3, WMA, AAC, WAV

 **NOTE:** MP4 or other formatted files may not be played and skipped. If accepted, it may not be played in good enough quality.

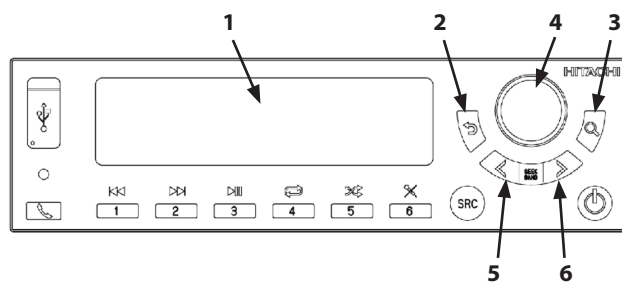

MNUD-01-402

**IMPORTANT:** The basic functions provided with this radio unit are explained in this section. It may not be applicable to the USB device depending on its specifications and application. Refer to the instruction manual of the USB connected device.

The track title, artist name, album name are displayed on LCD (1).

If they are too long to display in one line, they are separately displayed on different screens. Press return button (2) to change the screens.



MNUD-01-427

### Select Play List

Pressing search button (3) may import the playlist from the specified device such as iPhone.

Select a desired track and play, if available, using rotary switch (4).

### Select Folder/Album

Press SEEK BAND+ button (5) moves to the next folder or album stored in the USB device.

Press SEEK BAND- button (6) moves to the previous folder or album stored in the USB device.

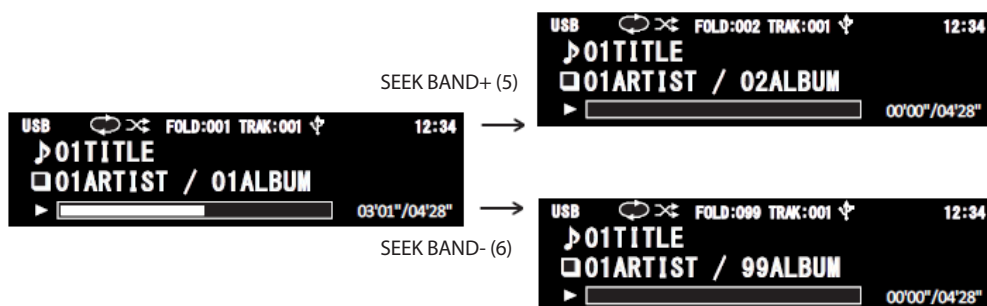

MNUD-01-426

## OPERATOR'S STATION

### Change Track

Press [2] button (2) to start playing the next track.

Press [1] button (1) to play the previous track.

According to the connected device setting, pressing [1] button (1) returns to the top of the currently playing track. Then press [1] again to play the previous track.

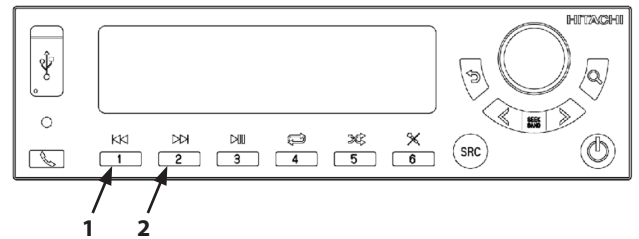

MNUD-01-402

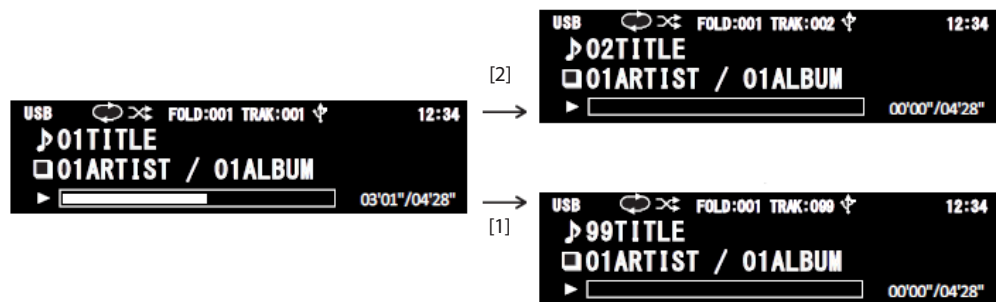

MNUD-01-428

### Fast-forward/Fast-rewind

While playing a track, depressing [2] button (2) fast-forwards the track until releasing [2] button. Fast-forward label (3) is displayed while depressing [2] button.

While playing a track, depressing [1] button (1) fast-rewinds the track until releasing [1] button. Fast-rewind label (4) is displayed while depressing [1] button.

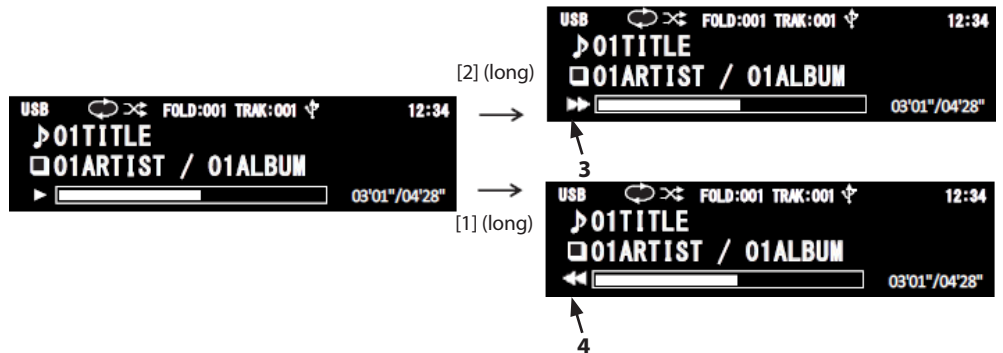

MNUD-01-429

## OPERATOR'S STATION

### Pause/Playback

Pressing [3] button (1) while playing a track pauses playback. PAUSE label (4) is displayed.

Pressing [3] button (1) again starts playing from where it was paused.

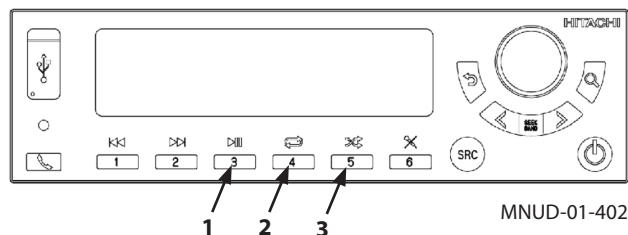

### Repeat

Pressing [4] button (2) plays the same track repeatedly. REPEAT label (5) is displayed.

Pressing [4] button (2) again plays the same album or folder repeatedly. REPEAT label (6) is displayed.

 *NOTE: This function is not applicable depending on the connected device.*

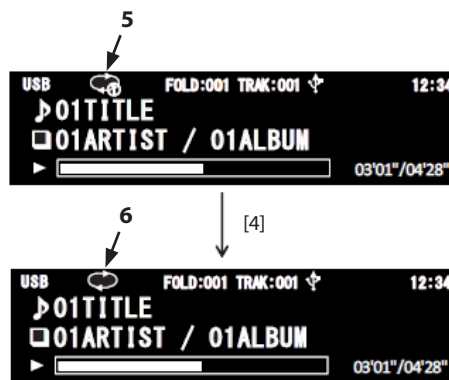

### Random

Pressing [5] button (3) plays the tracks in random order. RANDOM label (7) is displayed.

 *NOTE: This function is not applicable depending on the connected device.*



# OPERATOR'S STATION

## Setting Screens

Allow changes to the various settings.

Press rotary switch (1) from any source screen to display setting screen (2).

Or select SETTING from the source selection operation.

Refer to page 1-56 "Selecting Source" for details.

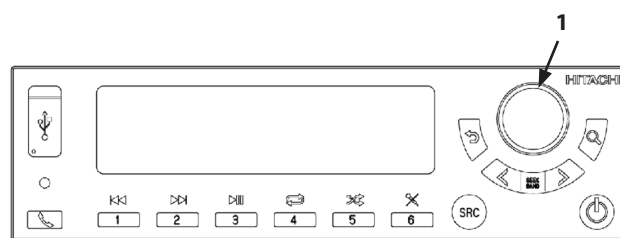

MNU01-402

There are 7 setting menu and their submenu.

Rotate rotary switch (1) and highlight a desired menu to set, and push rotary switch (1) to display its submenu.

		Default Setting
SOUND	* BALANCE	0
	* TREBLE	0
	* BASS	0
	* LOUDNESS	OFF
BRIGHTNESS	* DISPLAY	0
	* SWITCHES	0
PAIRING		
HANDSFREE	* AUTO ANSWER	OFF
Bluetooth® CONNECT	* AUTO CONNECT	ON
	SELECT	
	DELETE	
INFORMATION	SOUND	
	BRIGHTNESS	
	HANDSFREE	
	Bluetooth® CONNECT	
	REGION	
	VERSION	
CLOCK	* DISP	OFF
	TIME	
RESET		

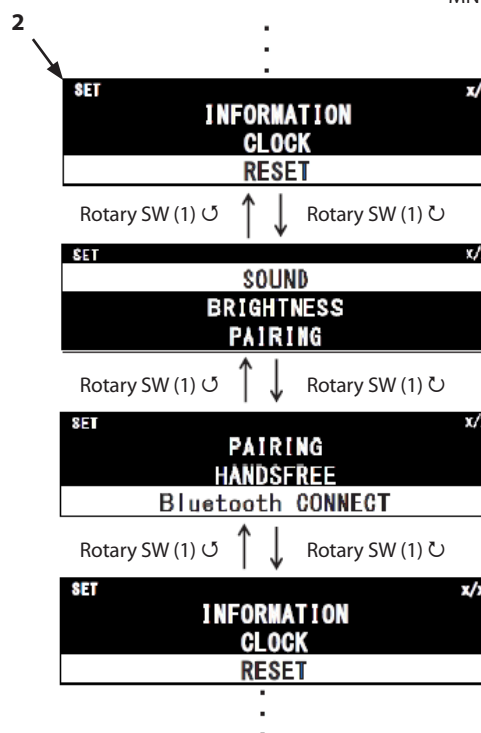

MNU01-451

## Reset Settings

To reset the setting values, select RESET and press rotary switch (1). "RESET ALL SETTINGS?" appears.

Highlight "YES" by rotating rotary switch (1) and press rotary switch (1). The setting for all the items with an asterisk mark (\*) in the above chart will be reset to the default setting.

Select "NO" to cancel the setting reset.

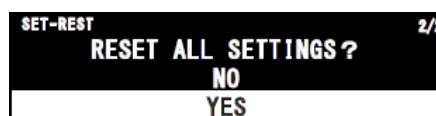

MNU01-434

## OPERATOR'S STATION

### Sound Setting

1. From "SOUND" setting menu, highlight the desired item to adjust by rotating rotary switch (1) and push rotary switch (1).
2. The setting screen appears.
3. Make adjustment by rotating rotary switch (1).
4. Push rotary switch (1) to fix the adjustment.
5. Pressing return button (2) cancels the setting and it returns to the Menu screen.

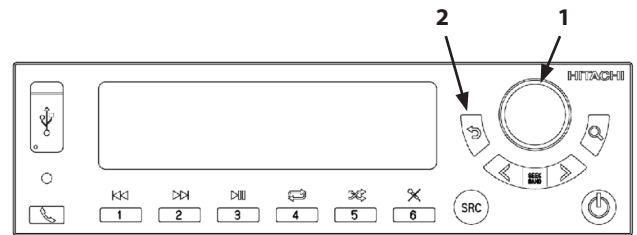

MNUD-01-402

- **Left/Right Output Balance Adjustment**  
Adjusts the output balance between the left and right speakers.  
There are 21 steps to this adjustment: L10 (left only) to L1, 0 (Center) and R1 to R10 (right only).
- **Treble Output Adjustment**  
Adjusts the high frequency part of the sound tone output to the speakers.  
There are 21 steps to this adjustment: +10 to 0 to -10.
- **Bass Output Adjustment**  
Adjusts the low frequency part of the sound tone output to the speakers.  
There are 21 steps to this adjustment: +10 to 0 to -10.
- **Loudness Setting**  
Adjusts the bass and treble ranges to be increased at low volumes to enhance hearing of those ranges.  
The setting is either ON or OFF.

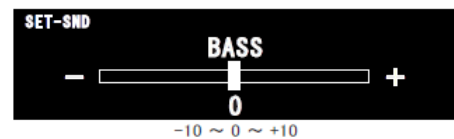
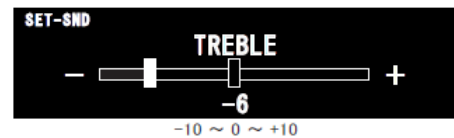
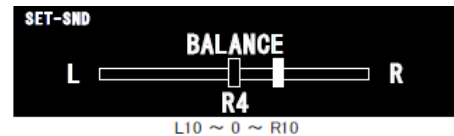

MNUD-01-435

## OPERATOR'S STATION

### Brightness Adjustment

1. From "BRIGHTNESS" setting menu, highlight the desired item to adjust by rotating rotary switch (1) and push rotary switch (1).
2. The setting screen appears.
3. Make adjustment by rotating rotary switch (1).
4. Push rotary switch (1) to fix the adjustment.
5. Pressing return button (2) cancels the setting and it returns to the Menu screen.

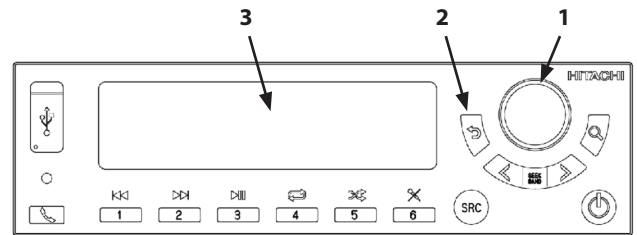

MNUD-01-402

- LCD Brightness  
Adjusts the brightness of LCD (3).  
There are 11 steps to this adjustment: +5 to 0 to -5.
- Switch Brightness  
Adjusts the brightness of activated switches.  
There are 11 steps to this adjustment: +5 to 0 to -5.

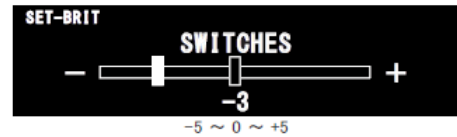
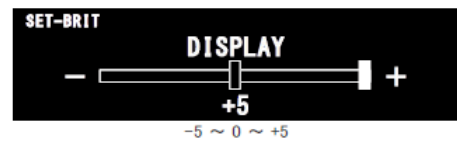

MNUD-01-436

## OPERATOR'S STATION

### Pairing

The pairing authenticates up to 16 Bluetooth® devices for use with this radio unit.

 **NOTE:** When the pairing is tried for the 17th device, it replaces any of the current 16 devices. To delete a Bluetooth® device, refer to page 1-76 for procedure.

1. Highlight "PAIRING" menu by rotating rotary switch (1) and push rotary switch (1).
2. "PAIRING START?" message appears on LCD (3).
3. Push rotary switch (1) to start the pairing.  
Push Return button (2) to cancel the pairing.

**IMPORTANT:** The pairing should be completed within 180 seconds after pairing starts.

4. Once the Bluetooth® module of the radio unit completes preparations, "PASS KEY: 0000" and "BT-\*\*\*\*" are displayed on the screen.

 **NOTE:** "\*\*\*\*" is the smallest 4-digit of the Bluetooth® module address.

5. If pairing is successful, "COMPLETED" is displayed. The Bluetooth® device operation is possible on this radio unit. Refer to page 1-62 for each operation.
6. If pairing fails due to timeout, etc., "FAILED" is displayed. Repeat the above steps again for pairing.

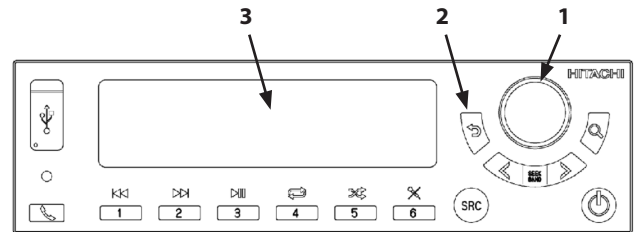

MNUD-01-402

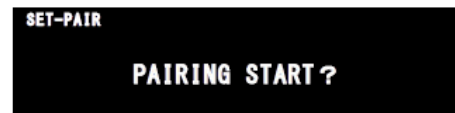

↓  
COMPLETED

↓  
FAILED

MNUD-01-438

## OPERATOR'S STATION

### Handfree Setting

1. Highlight "HANDSFREE" menu by rotating rotary switch (1) and push rotary switch (1).
2. AUTO ANSWER setting appears on LCD (2).
3. Select "OFF" and push rotary switch (1) to disable the auto-answering to an incoming call.
4. Select "ON" and push rotary switch (1).  
The time period before answering can be set among 1 to 30 seconds. Rotating rotary switch (1) clockwise increases the time by one second. Rotating rotary switch (1) counterclockwise decreases the time by one second. Push rotary switch (1) to fix the time.

This will automatically answer to an incoming call in the specified time period.

 **NOTE:** The call quality may vary depending on the connected device.

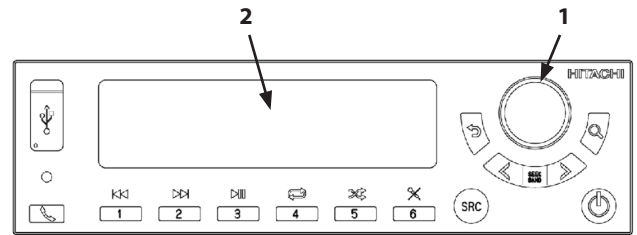

MNUD-01-402

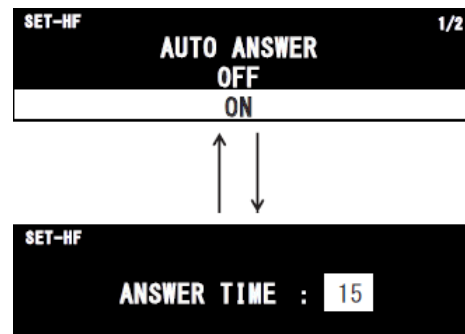

MNUD-01-439



## OPERATOR'S STATION

### Bluetooth® Connection

This specifies the connection method to the device after Bluetooth® pairing.

- From "Bluetooth® CONNECT" menu, highlight "AUTO CONNECT" by rotating rotary switch (1) and push rotary switch (1).

- Select either OFF or ON and push rotary switch (1).

- OFF: Disable auto-connection to a Bluetooth® device.
- ON: Automatically connect to the available device for which pairing in Bluetooth® is completed.

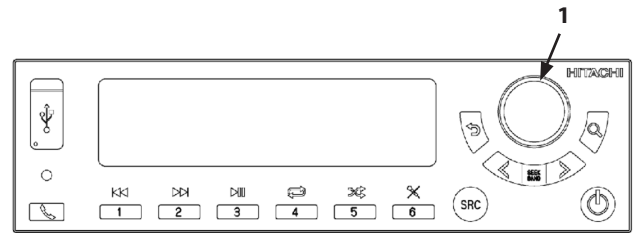

MNUD-01-402

- If "OFF" is selected in step 2, highlight "SELECT" from Bluetooth® CONNECT menu and push rotary switch (1).

**NOTE:** *SELECT is effective only when AUTO CONNECT setting is OFF.*

- The available Bluetooth® device name or the device address are listed.
- Select a device to connect by rotating rotary switch (1). Pressing rotary switch (1) starts connection to the selected device.

**NOTE:**

- If there is no device to connect in Bluetooth®, "NO DEVICE" is displayed.
- The device name is obtained when connecting the first time to the device after ACC ON. If the device name is changed after connection, the listed device name will not be updated.

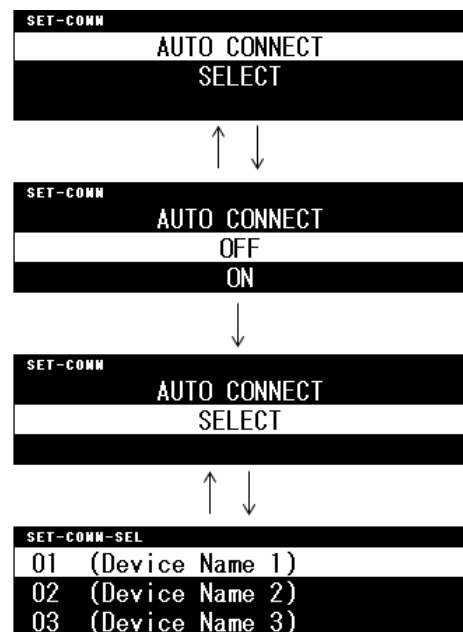

MNUD-01-440

# OPERATOR'S STATION

### Deleting Bluetooth® Device

The selected device is deleted from the device list from Bluetooth® CONNECT - DELETE menu.

Highlight a desired device and push rotary switch (1). Select "YES" and push rotary switch (1) to delete the selected device.



MNUD-01-402

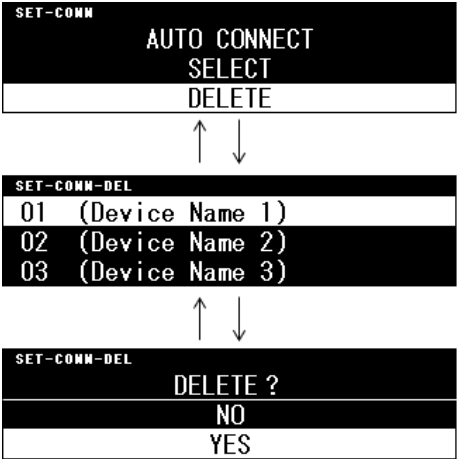

MNUD-01-441

## OPERATOR'S STATION

### Clock Display

The current time is displayed on LCD (2).

- From "CLOCK" menu, highlight "DISP" by rotating rotary switch (1) and push rotary switch (1).
- Highlight a desired setting and push rotary switch (1).

OFF: No time display  
ON: Time display in 24-hour format

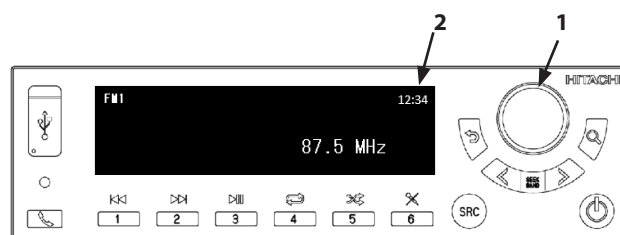

MNUD-01-402

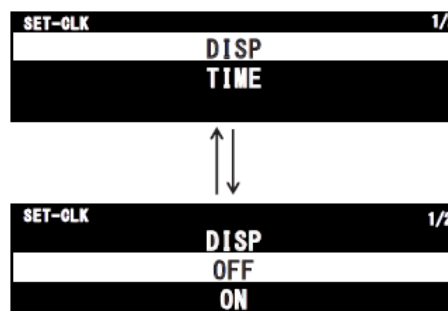

MNUD-01-442

### Time Adjustment

 **NOTE:** When the machine battery runs out, the clock becomes 00:00.

- From "CLOCK" menu, highlight "TIME" by rotating rotary switch (1) and push rotary switch (1).
- The time setting screen (3) appears.
- Highlight "HOUR" and push rotary switch (1). The hour can be set between 0 and 23.

Rotating rotary switch (1) clockwise increases number.  
Rotating rotary switch (1) counterclockwise decreases number.

- Push rotary switch (1) to fix the hour and returns to the time setting screen (3).
- Adjust "MINUTE" in the same manner. The minute can be set between 0 and 59.

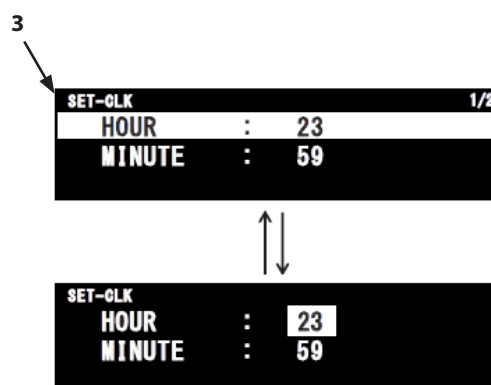

MNUD-01-444

# OPERATOR'S STATION

## Information

The current setting values are displayed.

1. From "INFORMATION" menu, highlight a desired setting by rotating rotary switch (1) and push rotary switch (1).
2. The current setting(s) are displayed. If there are 4 or more submenu, rotate rotary switch (1) to display them.

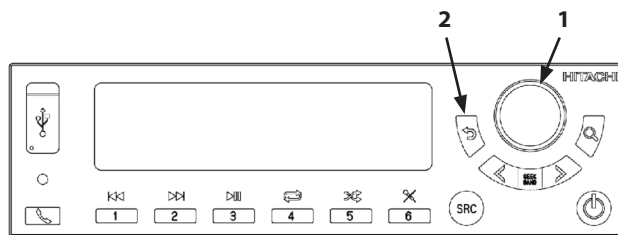

MNUD-01-402

**NOTE:** The REGION setting and VERSION information are additionally displayed in this menu.

- Region Display

Make sure the region displayed is "US."

AE: Europe, Asia, Australia

JP: Japan

US: USA, Canada

SA: Latin America

- Version Display

Displays the version of the radio unit's firmware, Bluetooth®, and USB protocol.

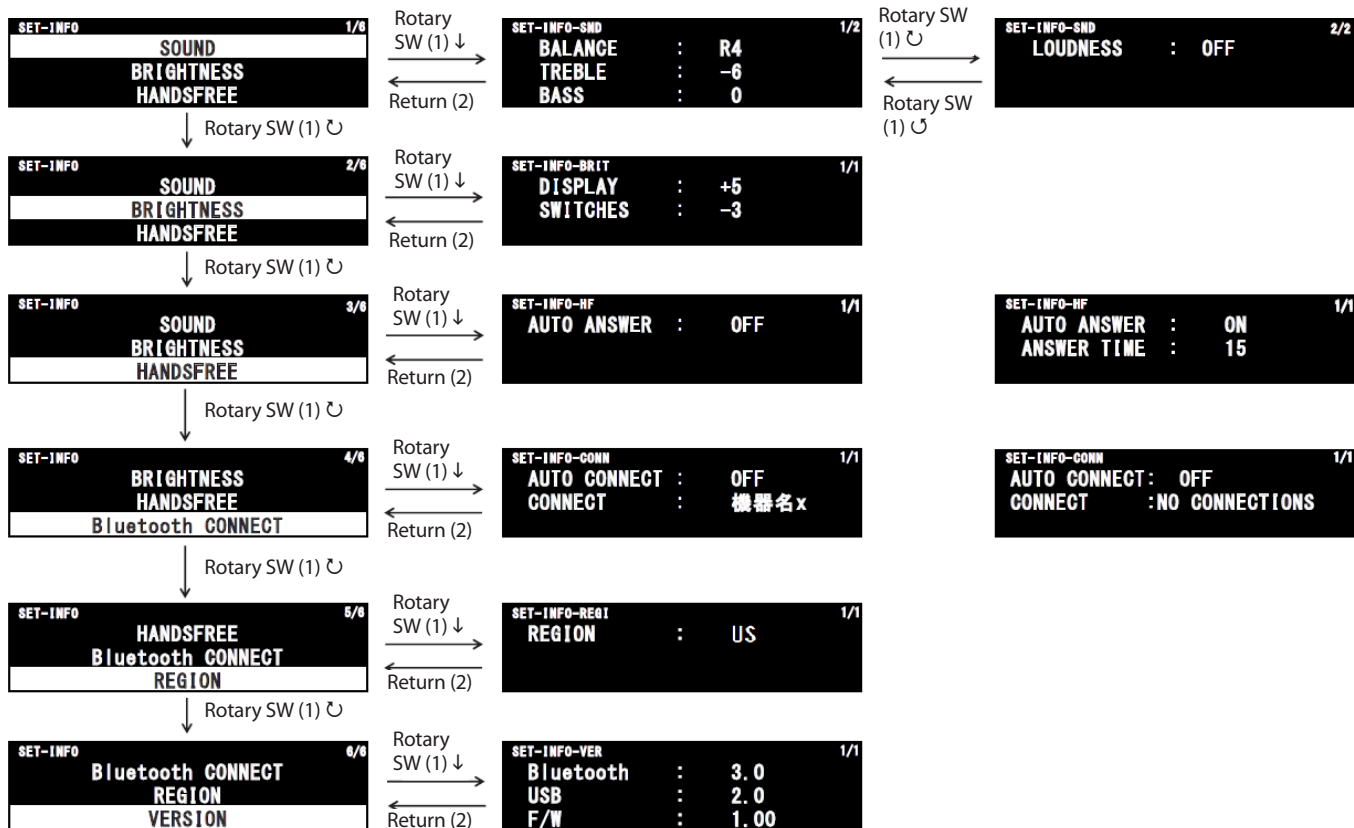

MNUD-01-445US

## BREAK-IN

---

### Observe Engine Operation Closely

**IMPORTANT:** Be extra cautious during the first 100 hours, until you become thoroughly familiar with the sound and feel of your new machine.

1. While operating the machine, limit the maximum engine horsepower to about 80 % of full load.
2. Avoid excess engine idling.
3. Check indicator lights and gauges frequently during operation.



## OPERATING THE ENGINE

### Check Before Starting

1. Check that forward/reverse lever (1) is in the neutral (N) position and that neutral lever lock (2) is in the lock position.

 **NOTE:** Unless both forward/reverse lever (1) is in neutral (N), the engine will not start.

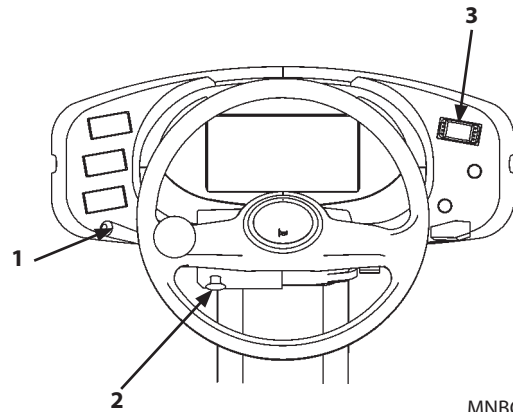

MNBC-01-011

2. Check that parking brake switch (3) is in the ON position and that parking brake indicator (4) is ON.

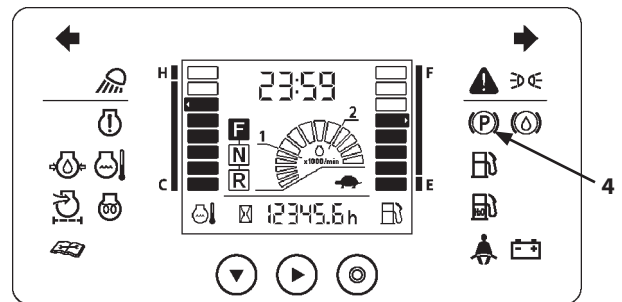

MNBC-01-024

3. Check that both loader control lever (5) is in the neutral positions.

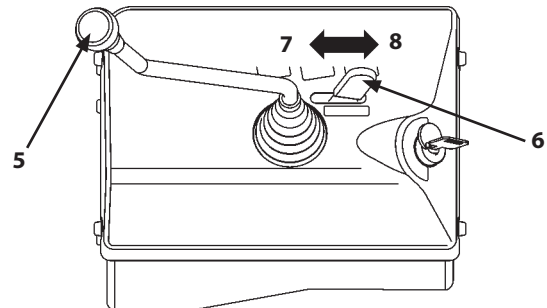

M4EK-01-061

4. Check that loader control lever lock (6) is in the LOCK position (7). Position (8) is the released (UNLOCK) position.

## OPERATING THE ENGINE

---

- Adjust the position of outside rear view mirror (9) and room rear view mirror (10) so that the best rear visibility can be obtained.

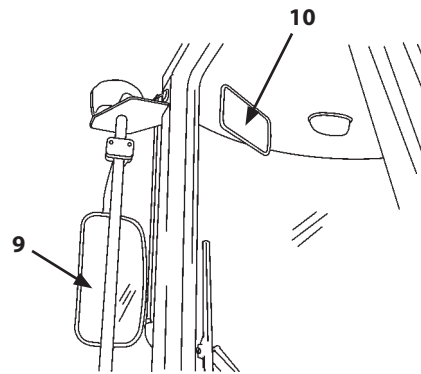

M4EK-01-035

- While seated on the operator's seat with your back in contact with the backrest, adjust each function of the seat so that the brake pedal can be fully applied.



SA-462

- Fasten seat belt.



SA-237



# OPERATING THE ENGINE

## Starting Engine

Start the engine following the procedures below.

1. Check that parking brake switch (1) is in the ON position.
2. Check that forward/reverse selector lever (2) is placed in neutral (N).
3. Check for burned indicator bulbs  
When key switch (3) is turned to ON position (6), all indicators and warning lights will come and stay ON. Parking brake indicator also turns ON. Any light fails to turn ON, the corresponding light bulb may be burned out. After the engine is started, all indicators and warning lights go OFF.
4. Sound the horn to alert bystanders around the machine.

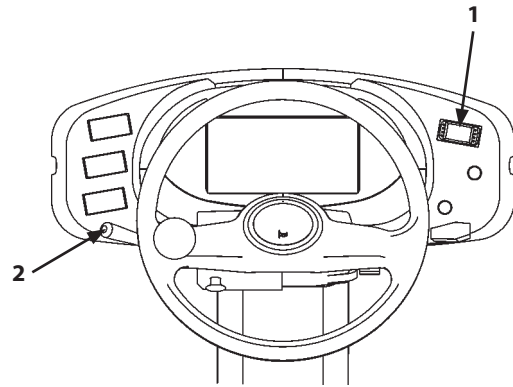

MNBC-01-011

**IMPORTANT: Do not allow the starter to run for longer than 10 seconds at a time. If the engine fails to start, return key switch to OFF. Wait for more than 30 seconds, then try again. Failure to do so may result in damage to the starter or discharge of the batteries.**

5. Turn key switch (3) to START position (7) to rotate the starter. The engine should start and run.
6. As soon as the engine is started, release the key. It will automatically return to ON position (6).

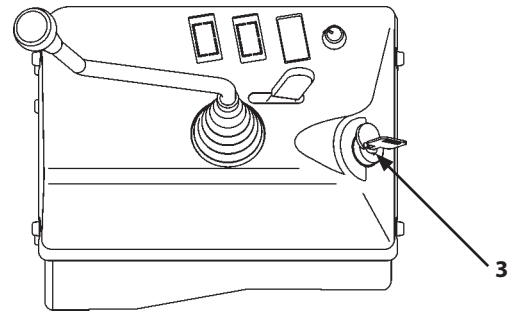

M4EK-01-013

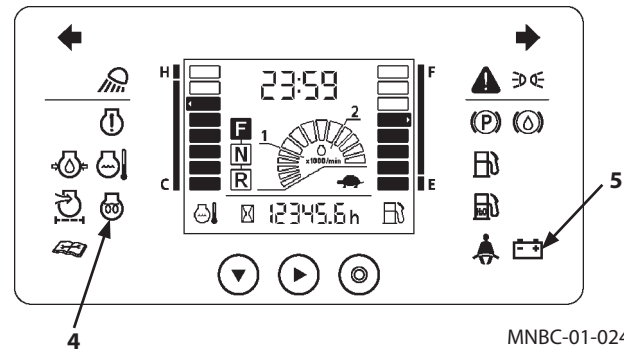

MNBC-01-024

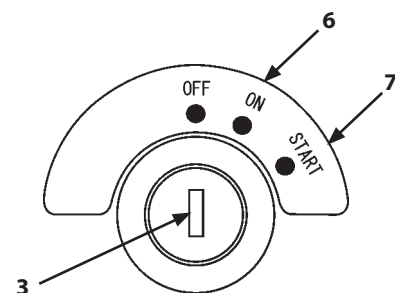

MNBC-01-013

## OPERATING THE ENGINE

### Starting in Cold Weather

#### Preheating

1. Turn key switch (3) to ON position (6) to preheat the engine.
2. Preheat indicator (8) turns ON. The engine is preheated until the preheat indicator goes OFF.

 **NOTE:** Preheating time differs depending on the coolant temperature.

3. As soon as preheat indicator (8) turns OFF, turn the key switch to START position (7) to run the starter. Release the key immediately after the engine starts. The key automatically returns to ON position (6). Perform warm-up operation described on page 3-8 after starting the engine.

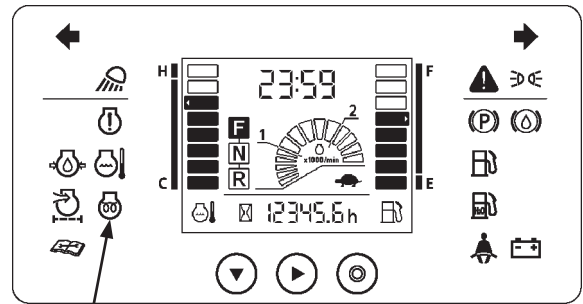

MNBC-01-024

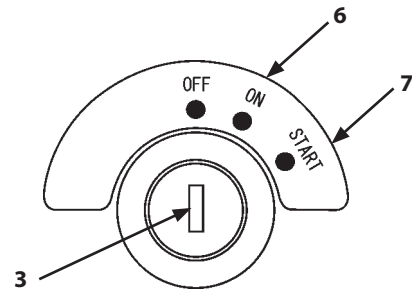

MNBC-01-013

## OPERATING THE ENGINE

### Check After Starting

**IMPORTANT:** If any abnormality is found in the monitor functions, immediately stop the engine and investigate the cause of the trouble.

#### Check the monitor operation:

1. Check that discharge warning indicator (1) is off. In case the discharge warning indicator stays ON, immediately stop the engine. Inspect the alternator and battery system for problems.
2. Check that low engine oil pressure indicator (2) is off. In case low engine oil pressure indicator stays ON, immediately stop the engine. Inspect the engine oil pressure system and the oil level.
3. Check that engine coolant temperature gauge (3) is within the green range.

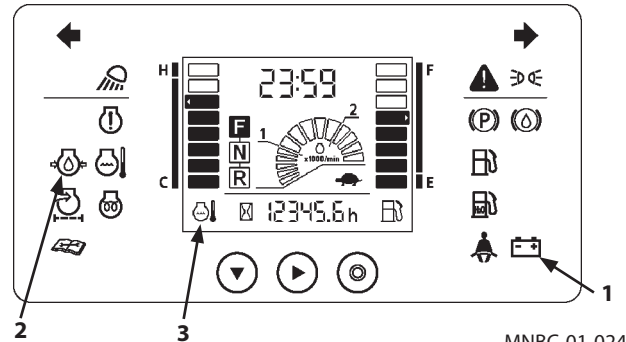

MNBC-01-024

#### Check engine noise and exhaust gas color:

Check that the engine noise and exhaust gas color is normal.

 **NOTE:** Check the exhaust gas color as follows. (After warm-up operation, run the engine with no loads.)

Exhaust gas color	Engine operating condition
Clear or light blue	Normal (Perfect combustion)
Black	Abnormal (Imperfect combustion)
White	Abnormal (Oil is leaking into the combustion chamber.)

## OPERATING THE ENGINE

---

### Using Booster Batteries

**⚠ DANGER:** An explosive gas is produced while batteries are in use or being charged. Keep open flames and sparks away from the battery area. Park the machine and a machine with the booster batteries on a dry or concrete surface, not on steel plates. If the machine is parked on steel plates, the machine is equivalent to a continuously grounded machine so that unexpected sparks may result. When connecting the booster cables, never connect a positive terminal to a negative terminal, as a dangerous short circuit may occur.

**IMPORTANT:** The machine electrical system is a 12 volt negative (-) ground. Use only 12 volt booster batteries.

If the machine batteries are completely discharged so that when starting the engine using booster batteries is necessary, do the following procedure.

## OPERATING THE ENGINE

---

1. Connecting the booster battery
  - 1.1 Stop the engine on the booster battery mounted machine.
  - 1.2 Connect one end of red booster cable (1) to the positive (+) terminal of the machine battery, and the other end to the positive (+) terminal of the booster battery.
  - 1.3 Connect one end of black booster cable (2) to the negative (-) terminal of the booster battery, and the other end to radiator mounting bolt on the machine. In the last connection to the bracket, sparks may fly so keep the machine battery as far away as possible from the bracket.
  - 1.4 After securely connecting the booster cables, start the engine on the booster battery mounted machine.
  - 1.5 Start the engine on the machine.
  - 1.6 After the engine starts, disconnect booster cables (1 and 2) in the following steps.
2. Disconnecting the booster cables
  - 2.1 Disconnect one end of black booster cable (2) from the radiator mounting bolt .
  - 2.2 Disconnect the other end of black booster cable (2) from the negative terminal of the booster battery.
  - 2.3 Disconnect one end of red booster cable (1) from the positive terminal of the booster battery.
  - 2.4 Disconnect the other end of red booster cable (1) from the positive terminal of the machine battery.

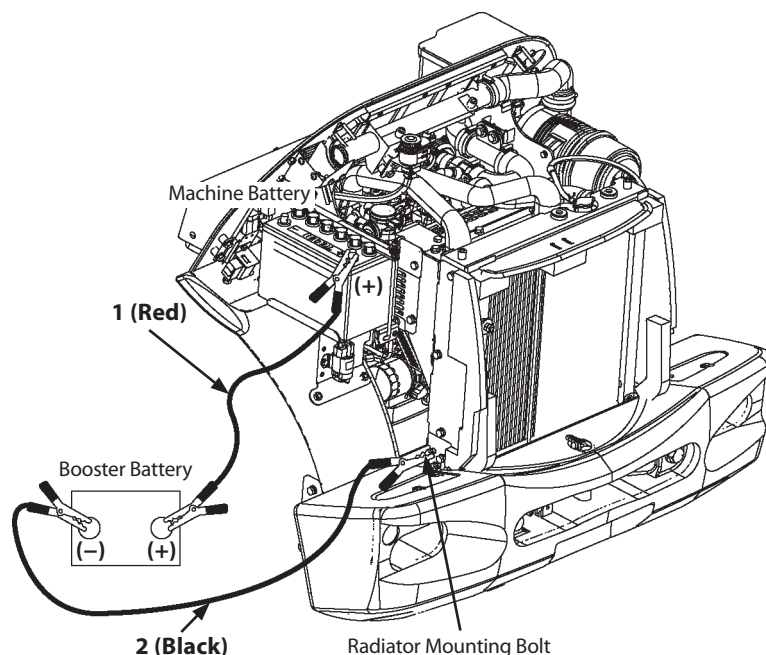

MNBC-03-001

## OPERATING THE ENGINE

---

### Warm Up Operation

If the machine is operated excessively with the hydraulic oil temperature below 20 °C (68 °F), damage to the hydraulic components may result. After starting the engine, warm up the hydraulic system as described below before operating the machine until the hydraulic temperature is above 20 °C (68 °F).

1. While slightly depressing accelerator pedal, run the engine at medium speed for about 5 minutes with no load.
2. Increase the engine at medium speed. Raise the bucket above the ground and hold loader control lever (1) in the tilt position (2) for 10 seconds. (Do not operate control levers other than the loader control lever at this time.)

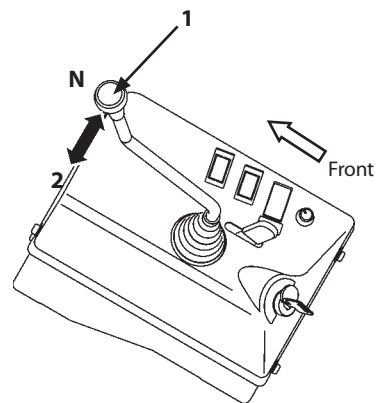

M4EK-03-003

## OPERATING THE ENGINE

---

### Warm Up Operation in Cold Weather

**IMPORTANT:** In case the hydraulic oil temperature is low, perform warm-up. Operate the machine only after the loader boom and bucket operating speeds are normal. Be sure to warm up not only to protect the hydraulic components from being damaged but also to ensure safe operation.

1. Run the engine at low idle speed for more than 5 minutes.
2. Run the engine at medium speed for 5 minutes.

 *NOTE: Do not run the engine at low or high idle at this time.*

3. Fully extend the bucket cylinder.

 *NOTE: Do not continuously operate the bucket control lever for more than 10 seconds at this time.*

4. Fully retract extend the bucket cylinder.

 *NOTE: Do not continuously operate the bucket control lever for more than 10 seconds at this time.*

5. Repeat steps 2 to 4 above until the boom and bucket operating speeds are normal. When the atmospheric temperature is lower than 0 °C (32 °F), extend the warm-up time by running the engine at middle speed.

## OPERATING THE ENGINE

### Stopping Engine

Stop the engine in the following procedures.

1. Lower the bucket before stopping the engine.
2. Run the engine at low idle speed for 5 minutes to cool the engine. Do not idle for excessively long periods. Observe local and federal engine idling regulations.
3. Turn the key switch (1) to OFF position (2) to stop the engine.
4. Be sure to place loader control lever lock (3) in the LOCK position (4).

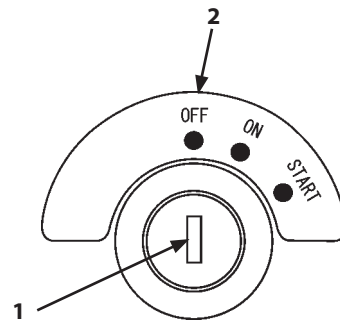

MNBC-01-013

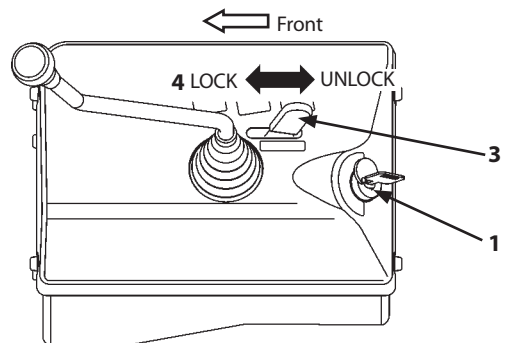

M4EK-01-061



# DRIVING THE MACHINE

## Driving Machine

### Driving

Correct operation will result in extending the service life of each part and component as well as saving fuel and oil. Always be sure to safely and efficiently operate the machine while paying attention to the following points.

### Precautions for Starting to Move

1. While checking the tires for abnormal air pressure and any obvious damage, make sure that there are no hazards and/or obstacles in and around the vicinity of the machine.
2. After raising the lift arm set the machine to the driving position, and fully tilt the bucket backward.
3. Before driving on public roads, set the machine to the driving position as illustrated to the right. Be sure to place loader control lever lock (1) in the LOCK position (2) so that the attachment will not move even if the control levers are accidentally operated.

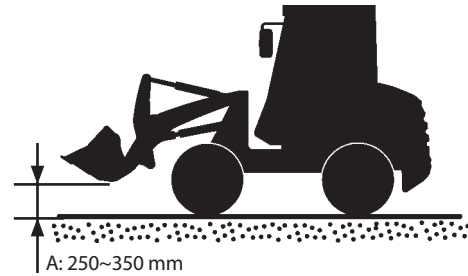

M4EK-04-001

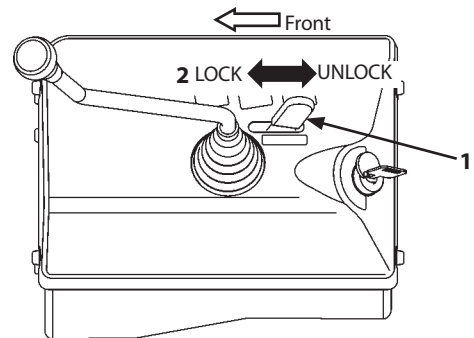

M4EK-01-061

## DRIVING THE MACHINE

### Starting to Move

**WARNING:** Start to move the machine only after checking that no personnel and/or obstacles are present around the machine.

1. Check that none of the warning indicators except parking brake indicator (1) on the monitor panel is ON.
2. Set the front attachment in the driving position by operating loader control lever (2).
3. Pull neutral lever lock (3) to the UNLOCK position (4).

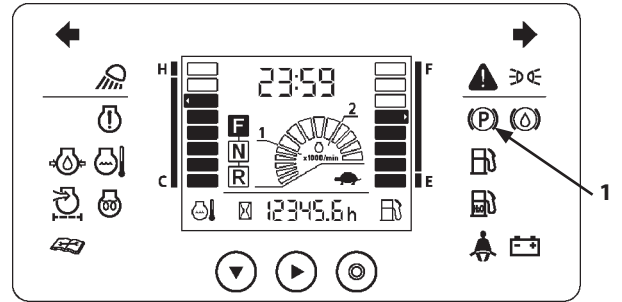

MNBC-01-024

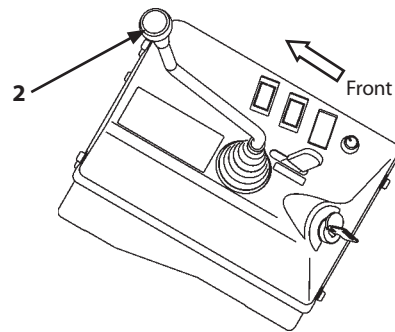

M4EK-01-007

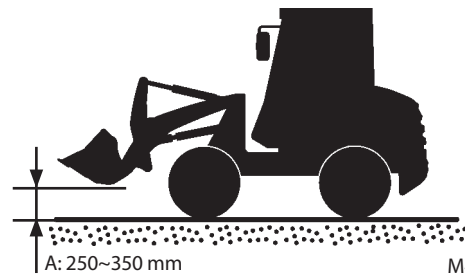

M4EN-04-001

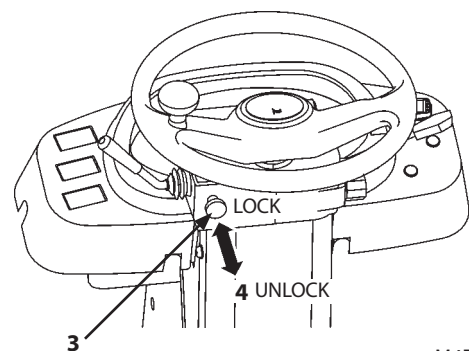

M4EK-01-009

## DRIVING THE MACHINE

- Step on brake pedal (5) and depress parking brake switch (6) to the OFF position to release the parking brake. Check that at this time parking brake indicator (1) go OFF.

 **NOTE:** When starting to move on a slope. While stepping on the brake pedal, depress the accelerator pedal (7). Slowly release the brake pedal (5) to allow the machine to easily start moving on a slope.

- Release brake pedal (5) and step on accelerator pedal (7).

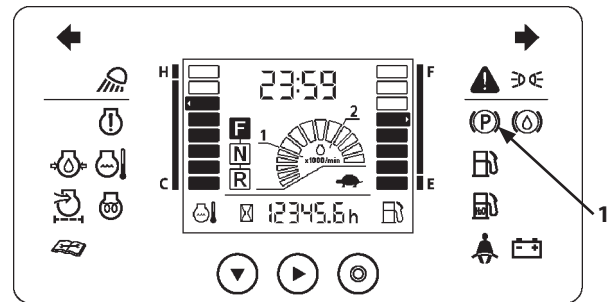

MNBC-01-024

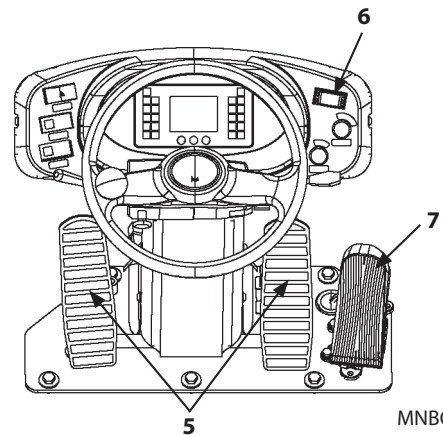

MNBC-01-007

## DRIVING THE MACHINE

### Parking Brake Switch

**⚠ WARNING:** To prevent the occurrence of accidents due to runaway of the machine, be sure to apply the parking brake when parking the machine and before leaving the machine.

Never apply the parking brake switch (1) while the machine is moving except in an emergency. Premature wear and/or damage to the parking brake may result. After the parking brake has been applied in an emergency while traveling the machine, have the parking brake checked at your nearest authorized dealer.

- Press the OFF side of parking brake switch (1) to release the parking brake. Check that parking brake indicator (2) goes OFF by pressing the switch twice. Press the ON side of parking brake switch (1) to apply the parking brake. Operate the parking brake after parking the machine on level ground.
- The parking brake is automatically applied when the engine is stopped even though parking brake switch (1) is OFF to ensure safe operation. In this case even after the engine is restarted, the parking brake will not be released. After starting the engine, turn ON parking brake switch (1) once. Then, turn OFF parking brake switch (1) to release the parking brake.

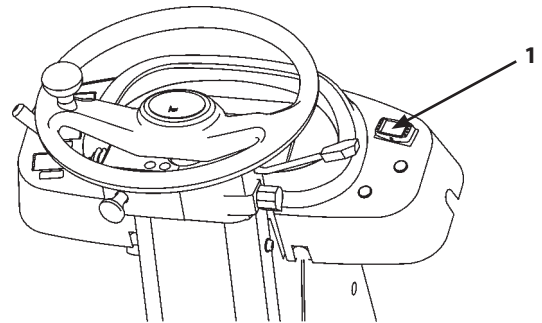

M4EK-01-006

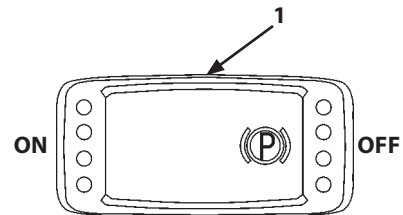

M4EK-01-025A

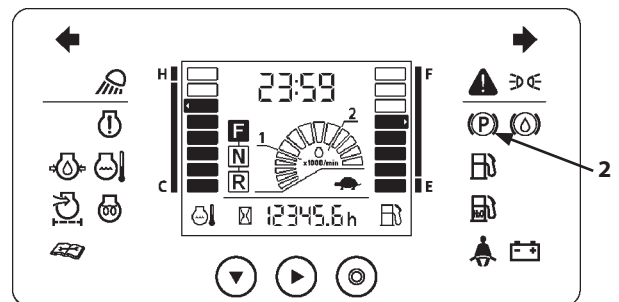

MNBC-01-024

## DRIVING THE MACHINE

### Changing Travel Speed

Travel speed of this machine is automatically shifted. Travel modes, LOW (work) and AUTO (Travel), are shifted by operating Travel mode switch (1). When Travel mode switch (1) is in the LOW (Work) mode position, green light (2) comes ON.

- LOW (Work) mode: Used to drive at the first speed stage, or to perform excavation or loading
- AUTO (Travel) mode: Used to drive at the first to second speed stage or to move the machine to another site.

**NOTE:** While traveling at high speed, avoid quick deceleration by operating Travel mode switch (1). Change the travel speed only after the machine decelerates by releasing the accelerator pedal.

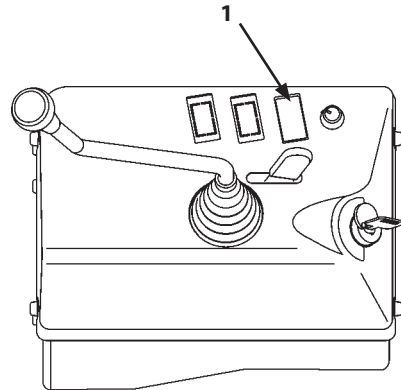

M4EK-01-013

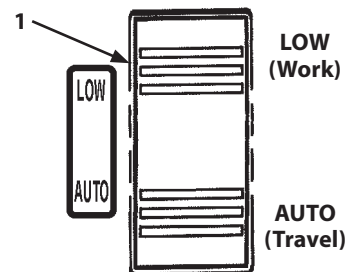

M4EJ-01-090

### Changing Forward/Reverse Drive Direction

**WARNING:** Before changing the drive direction, confirm that the travel direction is clear. To ensure operator's safety and ensure the longevity of the power train system, change the machine drive direction only after sufficiently reducing the drive speed.

1. Pull neutral lever lock (3) to the UNLOCK position.
2. Press the OFF position of parking brake switch (4).
3. Move forward/reverse selector lever (5) to the desired position.

F: Forward Driving  
N: Neutral  
R: Reverse Driving

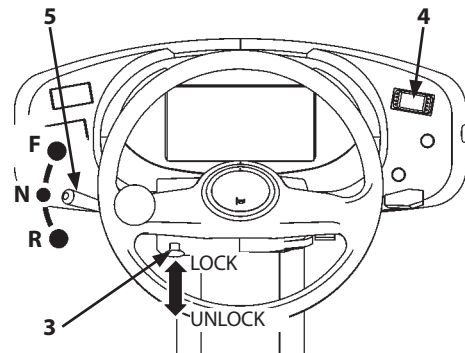

MNBC-04-001

## DRIVING THE MACHINE

---

### Steering

**⚠ WARNING:** Avoid sudden steering changes while driving the machine at high speeds, while driving on a steep slope, or while raising the lift arm to the maximum position. Failure to do so may cause the machine to turn over. Never attempt to stop the engine while steering the machine. If the engine is stopped, the steering wheel will lock and the parking brake will apply so that the steering will become impossible.

**IMPORTANT:** When the steering wheel is fully turned, the front and the rear frames come in contact with the stoppers so that the steering wheel does not rotate further. If the steering wheel is forcibly turned, the engine may stall or malfunction of the steering system may result.

Turn the steering wheel towards the direction you intend to steer the machine during drive operation.

**✎ NOTE:** *This machine has an articulated frame. The front and rear frames are coupled by a connection pin (center pin) so that the rear wheels follow the tracks of the front wheels. Turn the steering wheel smoothly so as to follow the motion of the machine.*

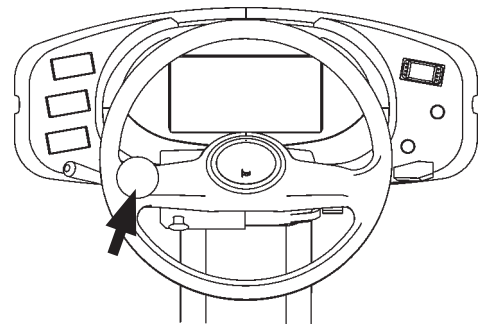

MNBC-01-011

## DRIVING THE MACHINE

---

### Stop and Restart of Travel

Follow the tips described below when required to provisionally stop or restart driving.

1. Slowly release the accelerator pedal. Depress the service brake pedal to stop the machine.
2. Slowly depress the accelerator pedal while releasing the service brake pedal to move the machine again.
3. When it is required to park the machine for a long period of time, return the forward/reverse selector lever to neutral, and apply the parking brake to ensure safety operation.
4. During drive operation, the machine drive position may be changed due to inner hydraulic oil leaks. When required to rectify the drive position, stop the machine, return the forward/reverse selector lever to neutral, apply the parking brake by turning the parking brake switch ON. Then, after rectifying the drive position, begin driving the machine again. Always allow the machine to maintain correct drive position.

### Precautions for traveling

During drive operation, observe the general operation best practice and the precautions described below to ensure safe and correct operation.

#### **WARNING: Use care to the following points:**

- **In case a tire becomes punctured while driving, securely hold the steering wheel and slowly reduce the drive speed. If the brake is suddenly applied by strongly depressing the brake pedal, the operator may lose steering control, possibly creating a serious accident. Never apply the brake quickly if a tire is punctured.**
- **Never mount or dismount a moving machine. Never allow any personnel other than the operator to ride on the machine when driving.**
- Even after break-in operation is complete, avoid running the engine at fast speed under no load.
- If any abnormal condition such as an abnormal noise, vibration, or smell is noticed during drive operation, immediately stop the engine and inspect the machine for any trouble.
- Avoid using sudden steering or braking as much as possible because not only your machine but also other machines may become involved in a hazardous condition.
- Driving speeds of this machine are lower than most normal automobiles. Always give the right of way to automobiles.

## DRIVING THE MACHINE

---

- Make it a habit to periodically scan the gauges and instruments. If any abnormality is recognized, immediately stop the machine and check the machine for the cause of the trouble.
- When required to drive on the road shoulder or in tight spaces, use a signal person.
- Slowly drive in or turn a crossing while paying attention to the visibility ahead and of the opposite driving lane.

### Traveling in Water or on Soft Ground

1. Do not submerge the front and rear axles, transmission, parking brake, or front and rear propeller shafts in water or mud. Avoid driving in water as much as possible.
2. If driving in water or mud is unavoidable, do not allow the machine to be submerged deeper than allowable depth (A) (up to the bottom of the axle housing). Reduce the allowable depth in case the river bed is feared to be rugged or water is flowing fast.
3. When driving/operating on muddy ground, mud can easily accumulate on the frame even if the frame is not heavily submerged in mud. Check regularly and clean as necessary.

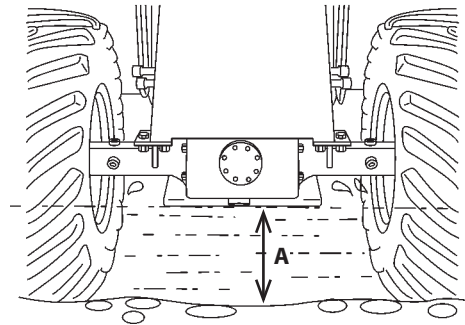

M4EJ-04-004A

**IMPORTANT:** If the axles, parking brake, transmission, etc. should become submerged, they must be reconditioned immediately, otherwise the parking brake may become inoperable, inner gears may wear excessively, or the machine may become damaged. Contact your nearest authorized dealer.

 **NOTE:** After operation is complete, be sure to wash and lubricate all submerged areas.



## DRIVING THE MACHINE

---

### Precautions for Driving on Slopes

**⚠ WARNING:** When descending a slope, do not drive the machine at a speed faster than the maximum travel speed. Damage to the machine and/or serious personal accident may result.

When steering on a slope, lower the loader front to increase the machine stability. Do not steer on a steep slope. Failure to do so may possibly cause the machine to turn over.

When descending a slope, travel the machine in the slow drive gear range using engine braking.

In case the engine stalls on a slope, immediately step on the brake pedal as strongly as possible, lower the front attachment to the ground and stop the machine. After moving the forward/reverse selector lever to neutral, restart the engine. The parking brake is automatically applied when the engine stops. Turn the parking brake switch ON before restarting the engine.

When continuously ascending a slope, the engine coolant temperature may increase in a short period of time according to the inclination pitch.

When the coolant temperature gauge indicates red zone (1) while ascending a slope, immediately stop the machine and run the engine at slow idle speed. Restart the machine when the coolant temperature falls in the center range.

- Before descending a slope, confirm that the brake system works normally by operating the brake pedal.
- In case the hydraulic oil and lubricant temperatures are low, the machine gradability may decrease. Before climbing a steep slope, sufficiently perform the warm up operation of the machine.



MNBC-01-029

## DRIVING THE MACHINE

---

### Precautions to Be Taken if the Machine Failure Occurs

- Remain alert. While paying attention to the vehicles following you, slowly reduce the travel speed and park the machine on the road shoulder as closely to the shoulder edge as possible. Turn the parking brake switch ON to apply the parking brake. When any machine failure is recognized in a short tunnel, park the machine outside the tunnel when possible.
- Use a sign that indicates that the vehicle is disabled. Unless a sign is used, collision with a following vehicle from behind may result. Indicate that the machine is disabled by using one or more of the following methods.
  - Use disabled machine triangles.
  - Turn the hazard lights ON.
  - Use an emergency signal instrument (emergency signal light).
  - Use a red flag or light.
- Check the failed section. If possible, repair the machine by yourself while ensuring safety and paying attention to the traffic conditions of other vehicles.

 **WARNING: Do not spill oil on the road surface. Oil spillage may cause another vehicle to slide, possibly creating a serious accident.**

- In case the hydraulic oil leaks, immediately repair it. If the road surface is severely covered with oil, take the highest priority to notify the following vehicles of this danger. Then, recover the leaked oil as soon as possible.
- In case the repairing the machine by yourself is impossible, contact your nearest authorized dealer.
- Repair work in the tunnel is very dangerous. Avoid working outside the vehicle even simple tasks.

## DRIVING THE MACHINE

### Stop/Parking

1. Avoid sudden deceleration. Smoothly reduce the travel speed. Release accelerator pedal (1) and step on brake pedal (2) to stop the machine.
2. Stop and park the machine on level surface. Lower the bucket level to the ground.
3. Return forward/reverse lever (3) to neutral (N). Place neutral lever lock (4) to the LOCK position (5).
4. Press the ON position of parking brake switch (6).
5. Move the lock position (9) of loader control lever lock (8).
6. Run the engine at low idle speed to cool the engine for 5 minutes. Do not idle for excessively long periods of time. Observe local and federal idling regulations.

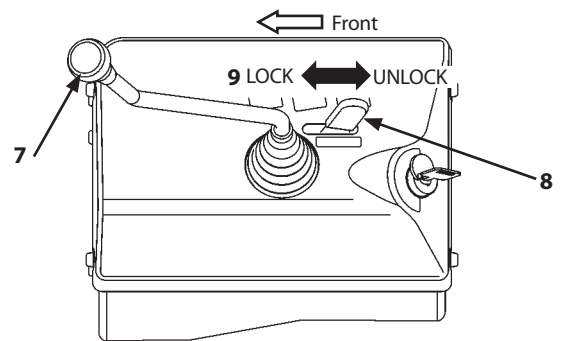
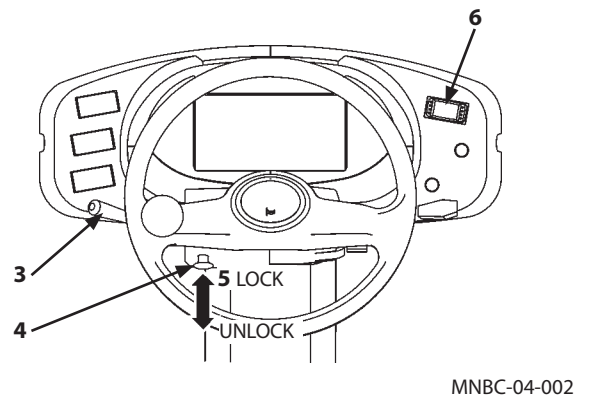
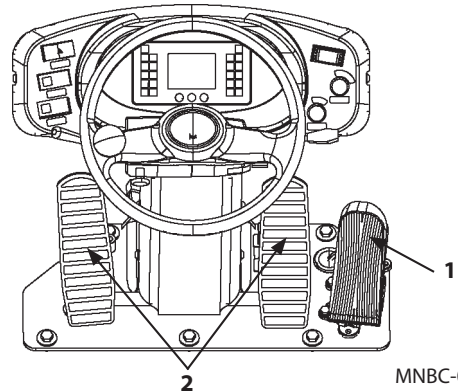

Stop and Parking Attitude

## DRIVING THE MACHINE

- Turn the key switch (10) to OFF position (11) to stop the engine. Remove the key from the switch.

**IMPORTANT:** If the key switch (10) is left in ON position (12), the batteries will discharge. Be sure to turn key switch to OFF position (11) before leaving the machine.

- Before leaving the machine, close and lock all the windows, cab doors, and covers.

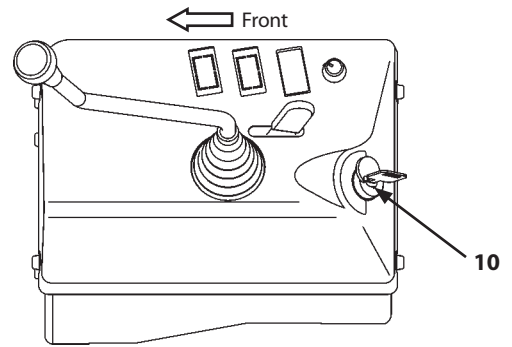

M4EK-01-013

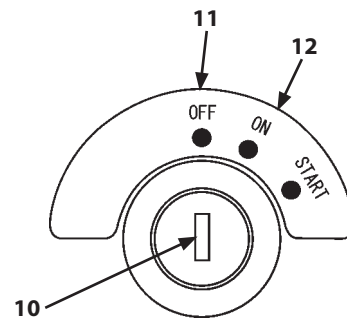

MNBC-01-013

## DRIVING THE MACHINE

---

### Emergency Occasions

#### **If the Engine Stalls During Traveling**

The parking brake is automatically applied so that the machine is stopped. As the hydraulic system becomes deactivated, the steering system becomes very difficult to operate. Horizontally lower the front attachment such as the bucket to the ground to ensure safety.

When towing the machine to a safe location, refer to the descriptions on "Precautions for Towing" in the transportation section.

In the event any symptom mentioned above occurs, immediately trace the cause of the problem. In case a complicated failure has occurred, consult your nearest authorized dealer.



# OPERATING THE MACHINE

## Loader Control Lever

### Single-Lever Type

Is used to operate the lift arm and/or bucket.

- (C) Float: The lift arm free falls and can be moved as loads are applied.
- (B) Lift arm Lower
- (N) Hold: The lift arm and bucket are stopped and held in that position.
- (A) Lift arm Raise
- (E) Bucket Dump: The bucket is tilted forward to dump the bucket load.
- (D) Bucket Tilt: The bucket is tilted back (or rolled back), taking the transportation position.
- (G) Detent: When the loader control lever is moved from the bucket dump position to the bucket tilt position, the loader control lever is maintained in this position. (Also known as Auto Level)

 **NOTE:** After dumping the bucket, when loader control lever (1) is pulled further from the TILT position (D), the lever is held in that position (G). Then, as soon as the bucket is tilted up to the position set by the bucket auto-leveler, loader control lever (2) is automatically returned to the HOLD position (N).

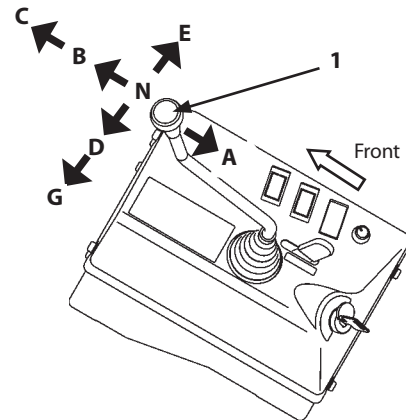

M4EK-01-007

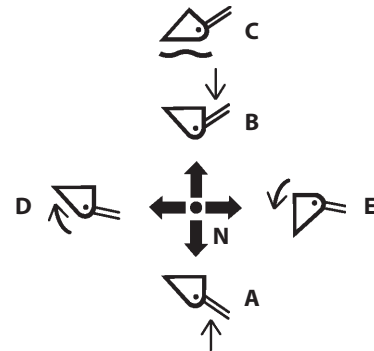

M4GB-01-074

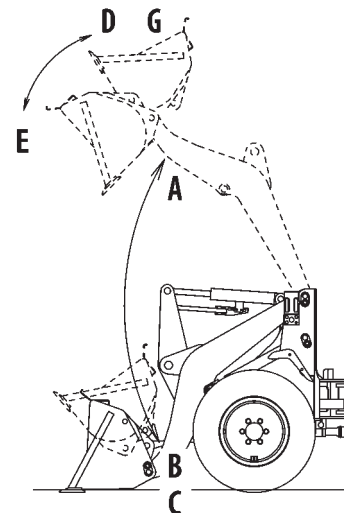

M4EJ-01-031A

## OPERATING THE MACHINE

### Lever Locks

**WARNING:** When locking the loader control lever and the auxiliary control lever (3) (optional), securely shift lever locks (2), (4) to the LOCK position. Unless lever locks (2), (4) are fully moved to the LOCK position, the control levers are not locked, possibly creating a hazardous situation.

Before leaving the operator's seat, be sure to stop the engine. Then, move lever locks (2), (4) to the LOCK position.

After completing operation of the machine or transporting the machine, be sure to move lever locks to the LOCK position.

Lever locks (2), (4) are provided to prevent the machine from being unexpectedly operated if the operator mistakenly comes in contact with loader control lever (1) or auxiliary control lever (3) (if equipped) when getting on or off the machine. When loader control lever (1) and auxiliary control lever (3) (optional) are placed in the UNLOCK position, the levers become operable.

**NOTE:** Auxiliary control lever (3) and lever lock (4) are optional.

#### Loader Control Lever Lock Operation

- When leaving the operator's seat:
  1. Park the machine on solid level ground. Lower the bucket to the ground. Return all levers to neutral. Stop the engine.
  2. Be sure to move lever lock (2) in the LOCK position.  
Be sure to place lever lock (4) in the LOCK position when auxiliary control lever (3) is not in use.

- Before starting operation:

Before starting operation, check that lever lock (2) is in the UNLOCK position.  
Be sure to place lever lock (4) in the UNLOCK position when auxiliary control lever (3) is in use.

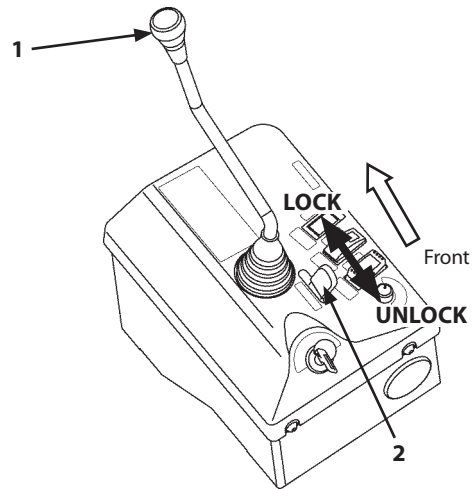

M4FG-01-023

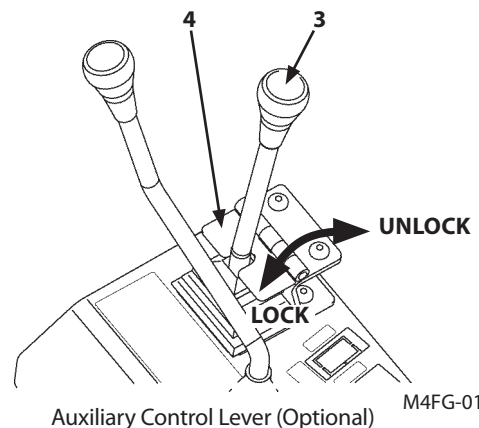

M4FG-01-024



## OPERATING THE MACHINE

### Adjustment of Bucket Auto Leveler

**⚠ WARNING:** Be careful to avoid personal injury and/or death when adjusting the bucket auto leveler. Stop the engine. Lower the loader front attachment to the ground to release the remaining pressure the hydraulic circuits. Apply the parking brake to prevent the machine from moving unexpectedly. Chock wheels with blocks. Keep bystanders away from the vicinity of the machine.

The bucket auto leveler automatically stops the bucket movement at the preset digging angle. (When the machine is shipped from the factory, the bucket positioner is preset so that the bucket is stopped with the bucket bottom parallel with the road surface.)

For example, after discharging the handling materials onto a truck or into a hopper, when loader control lever (4) is placed to detent position (G), the lever is held in that position. Then, when the bucket is returned to the preset angle position, the bucket is automatically stopped and the lever is returned to neutral (N).

The bucket auto leveler is preset so that when the bucket bottom becomes parallel with the road surface, the bucket is stopped. Nevertheless, when required to tilt the bucket forward or backward more than level position, adjust the bucket auto leveler by moving the mounting position of the proximity switch.

#### Adjustment Procedures

1. After moving the bucket to the desired digging angle, stop the engine.

**IMPORTANT:** Do not operate the machine with the bucket dumped more than 10°. Avoid applying great downward force to the bucket cutting edge.

2. Loosen lock nut (2) tightening the proximity switch to the base machine. Slide the end edge of positioner (3) up to the center of the sensitive area (orange color) (5). Then, tighten lock nut (2).
3. After adjustment start the engine. Check that the bucket can be stopped at the preset angle position.

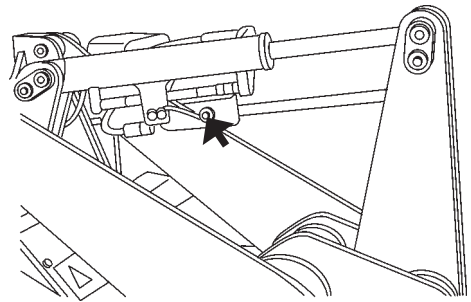

M4EJ-05-002

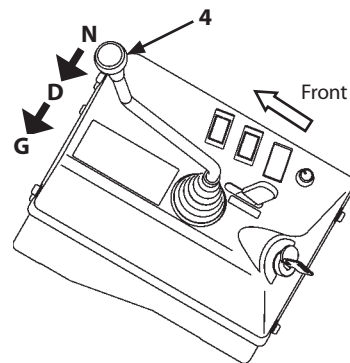

M4EK-01-007

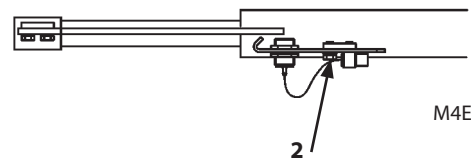
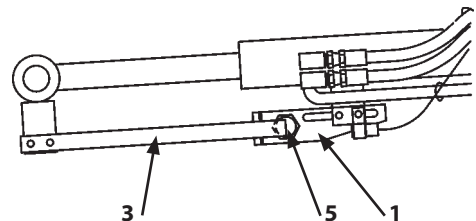

M4EJ-05-003

## OPERATING THE MACHINE

---

### Before Operation

**⚠ WARNING:** Be sure to install only authorized buckets and other work tools on the front attachment. Never modify or increase the capacity of the bucket or other work tools without first receiving authorization. Do not overload the machine by installing additional counterweights. Failure to do so may result in personal injury and/or machine trouble.

### Precautions for Operation

**⚠ WARNING:** Confirm work site safety before starting operation. Especially be sure to observe the points below:

- Use the machine equipped with FOPS and ROPS if the machine is to be operated in the areas where the possibility of falling stones exists.
- If operation on excessively soft ground is required, operated the machine only after reinforcing the ground.
- Be sure to wear close fitting clothing and safety equipment appropriate for the job, such as a hard hat, etc. When operating the machine.
- Clear all persons and obstacles away from the area of operation and machine movement. Always be aware of the area around the machine while operating.

### Ensure Safety When Operating on Road Shoulders

**⚠ CAUTION:** Reinforce the ground before operating the machine on soft road shoulders.

## OPERATING THE MACHINE

---

### Avoid Overloading

**⚠ WARNING:** Do not penetrate the bucket into piles of soil and/or gravel at fast travel speed to avoid accidents. Avoid excavating or scooping loads when the machine is articulated, which could possibly cause the machine to turn over.

### Avoid Rapid Steering Changes and/or Sudden Braking

**⚠ WARNING:** Always maintain a flat work site surface. Avoid rapid steering changes and sudden braking while raising the lift arm with the bucket loaded to prevent the machine from turning over.

## OPERATING THE MACHINE

### Excavation

#### Loading Accumulated Soil

Scoop load while traveling forward as described below. As load increases the wheels begin to slip, slightly raise the bucket to reduce the load.

1. Level the bucket with the surface of the ground. Penetrate the bucket into the accumulated soil while traveling forward.
2. After the bucket has sufficiently penetrated the soil, raise the lift arm while traveling forward further and occasionally tilt the bucket back to fill the bucket.
3. If it is difficult to penetrate the soil with the bucket, move the bucket back and forth and the bucket teeth up and down.
4. Drive the machine with the bucket tilted backward fully and held at the lowest possible position.



M4EK-05-001



M4EK-05-002



M4EK-05-003

**IMPORTANT:** Avoid operating the machine with the front wheels raised off the ground. Machine traction force is reduced and excessive loads are applied to the undercarriage.

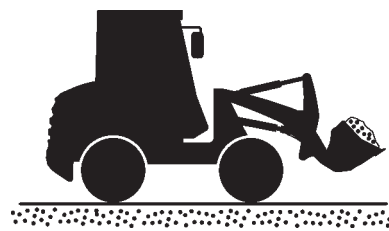

M4EK-05-004

## OPERATING THE MACHINE

---

### Digging and Loading Level Ground

**IMPORTANT:** While excavating with the bucket or fork, never apply excessive force to the tooth tips with the bucket or fork tilted more than 10 degrees. This may result in cracking or damaging the work tools.

Slightly position the bucket teeth downward (0 to 10 degrees) and dig the ground while traveling forward as described below. Always take care not to apply loads to only one side of the bucket.

1. Position the bucket teeth slightly downward.
2. While traveling forward, tilt the bucket so that the ground surface is gradually separated.
3. Adjust the digging depth by operating the lift arm.
4. Carry material with the bucket tilted backward fully and held at the lowest possible position.



M4EK-05-005



M4EK-05-006

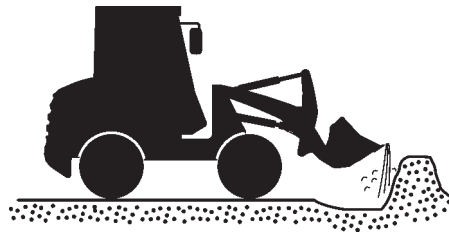

M4EK-05-007

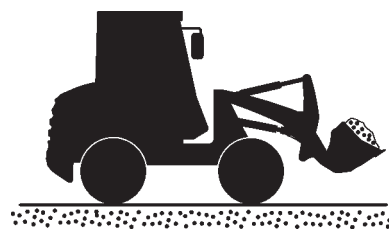

M4EK-05-008

## OPERATING THE MACHINE

---

### Grading

**IMPORTANT:** Be sure to perform grading work while traveling in reverse. If grading work is performed by traveling forward, severe loads are applied to the front attachment, possibly creating cracks or damage to the front attachment.

1. After filling soil into the bucket, dump the bucket gradually to disperse soil while traveling in reverse.
2. Lower the bucket teeth tips onto the ground. Grade and level the ground surface while traveling in reverse with the bucket teeth tips dragging.
3. After filling the bucket with a load such as soil, position the bucket level with the ground surface. Finish the ground surface utilizing the bucket weight. At this time, travel in reverse with the lift arm held in the FLOAT position.



M4EK-05-009



M4EK-05-010.



M4EK-05-011

## OPERATING THE MACHINE

---

### Loading

**IMPORTANT:** Always maintain a clean travel surface. Cleaning of materials such as soil spilled on the driving surface will reduce wear and/or damage on tires.

**IMPORTANT:** When carrying loads in the bucket, pay attention to the travel surface conditions. Travel at such speed so that the load will not spill out of the bucket, while positioning the bucket at the lowest possible height.

**IMPORTANT:** Refrain from banging the bucket with the bucket stopper as much as possible when removing stuck material, like clay, from the bucket. Failure to do so may result in damage to the front attachment. Remove material stuck to the bucket by washing with water.

Loading is dumping the handling material onto a truck or into a hopper. Loading work is performed in either the load and carrying method or loader and dump truck method. Select either method depending on the work site conditions while taking the merits in cost and safety into account.

#### Load and Carrying Method

**WARNING:** Be sure to provide tire stopper (1) in front of the dumping port.

**WARNING:** Before raising the lift arm, slightly tilt the bucket back and forth to stabilize the load in the bucket to avoid personal injury or damage to the machine due to material loss.

**WARNING:** When approaching the machine to a hopper with the lift arm raised to a high enough position, travel slowly. Never rapidly operate the machine while approaching a hopper to prevent turning over.

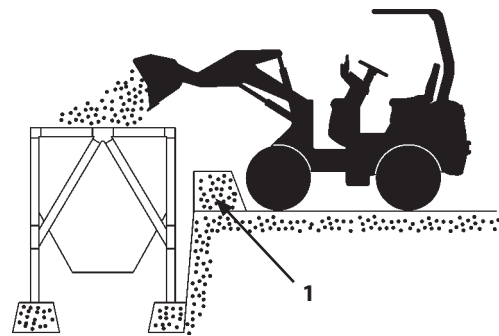

M4EJ-05-015

A wheel loader performs work process of loading, carrying, and dumping in sequence. Generally, when the carrying distance is 30 to 100 m, this method is employed. Make an upgrade slope of approx. 3 ° around a hopper when dumping into the hopper. Be sure to provide a level area 10 m apart from the hopper and tire stopper (1) at the hopper edge. Reduction in travel speed will assist operator's braking effort.

## OPERATING THE MACHINE

### Loader and Dump Truck Combination Method

A loader carries out loading and carrying and dumping is carried out by a dump truck. Either V- or I-shape loading method is employed in this method. Depending on the work site conditions encountered and matching with available trucks, select the most efficient method.

#### WARNING:

- **Always maintain a level work site surface. Avoid rapid swing and/or sudden braking while raising the lift arm with the bucket loaded to prevent the machine from tipping over.**
- **Do not penetrate the bucket into a loading face at fast travel speeds, possibly resulting in an accident.**

### V-Shape Loading

1. Park a dump truck in a spot located at approx. 60° angle toward the loading face. After loading material, travel the wheel loader in reverse and turns its direction so that the wheel loader faces the parked dump truck at a right angle. Then, travel forward to carry material onto the dump truck.
2. Position the wheel loader so that the material can be loaded around the center of the dump body. In case the dump body is longer than twice the bucket width, load from the front to rear position of the dump body in order.
3. Before raising the lift arm to the maximum height with the bucket full, lightly tap the bucket on the ground to stabilize the material in the bucket to prevent the material from spilling off the backside of the bucket.

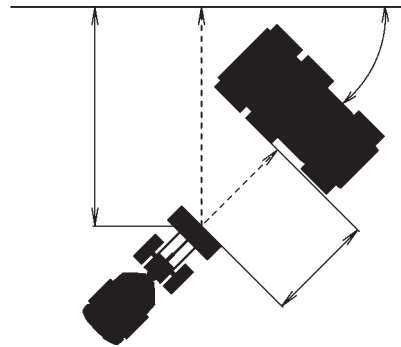

M4EJ-05-016

### I-Shape Loading

Park a dump truck in a direction parallel to the loading face. After loading material into the bucket, travel the wheel loader straight in reverse. Then, move a dump truck to a spot between the loading face and the wheel loader. Travel the wheel loader forward to load material onto the dump body. Loading times become shorter using this loading method, reducing the total working cycle time and increasing work efficiency. Position the machine down the wind as much as possible. The engine will not only inhale as little dust as possible but also operator's eyes will be protected from being contaminated.

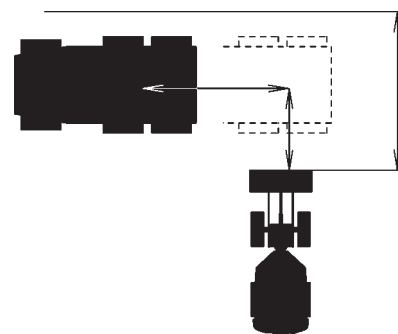

M4EJ-05-017



---

## OPERATING THE MACHINE

---

### Dozing

Dozing stands for a working method performed by a wheel loader using the wheel loader bucket in place of a bulldozer blade. This operation method is employed when reclaiming land or dumping material into a hopper that is below ground level. Set the bucket bottom parallel with the ground surface and move the wheel loader forward.



M4EJ-05-018

**IMPORTANT:** Never attempt to forcibly push piled material higher than the bucket capacity. Premature wear of the tires due to slipping and/or waste of fuel may result.

**IMPORTANT:** Do not perform dozing with the bucket dumped. Abnormal excessive stress will be increased on the front attachment, and the lever can bend, causing problems with the geometry.

**IMPORTANT:** Never apply great traction force to the cutting edge with the cutting edge tilted forward more than 10°. Failure to obey so may result in damage such as cracks to the working tools and front attachment.

### Scooping

- ⚠ WARNING:** Do not allow the machine to engage in piling up material on a soft ground. It is important to be aware that steering operation on soft ground may easily cause the machine to tip over.
- ⚠ WARNING:** When piling up material with this machine, do not operate the machine in too steep an incline, as the counterweight can come in contact with the ground. The machine may become unstable, possibly causing the machine to turnover. In addition, impact loads to be applied to the counterweight may cause the mounting bolts to become loose and/or to break.



M4EJ-05-019

## OPERATING THE MACHINE

---

### Removing Snow

**CAUTION:** Remove snow in the same method as employed in general loading work. However, pay attention to slippage of tires and obstacles covered with snow.

Precautions for removing snow

- Avoid sudden starting and stopping as well as rapid steering of the machine.
- Use tire chains on all four wheels.
- Pay attention to the presence of the utility facilities such as a fire hydrant, a manhole, edge stones, roadside drains, etc.

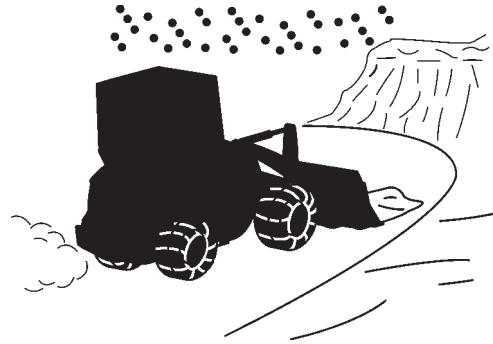

M4EJ-05-020

### Lifting Wheel Loader

**WARNING:** Be sure to use the specified lifting tools (option) and set the articulation lock bar in the LOCK position. Never allow any person to ride on the machine to be lifted. Never allow any person to enter below the lifted machine. Before fully lifting the machine above the ground, check that the hooks are securely attached to the machine and the machine is well balanced while lifting the machine slightly above the ground. Refer to the "LIFTING MACHINE" in the TRANSPORTING section.

Lifting work of the machine may become necessary when loading the machine onto a ship or truck for repairing and/or transporting.

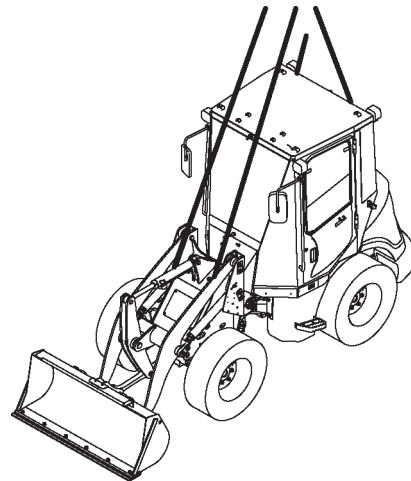

M4EJ-05-021

## OPERATING THE MACHINE

### Precautions for After Operation

1. After finishing operation, move the machine to firm, level ground where no possibility of falling stones, ground collapse, or floods are present. Park the machine referring to the "PARKING THE MACHINE" in the "DRIVING THE MACHINE" section.
2. Refill the fuel tank.
3. Clean the machine.

**CAUTION:** Wash the machine immediately after operation and then coat rust-preventive oil to protect the machine from rusting. If the machine continues to be used with rust developing, oil leaks may occur.

4. Maintenance for long term machine storage after engaging in snow removal  
Anti-freeze agents such as salt (sodium chloride or calcium chloride) are scattered on snow roads. When the machine is stored for a long time after engaging in snow removal work, perform the following maintenance to protect the machine from being corroded and/or damaged by salt.
  - 4.1 Clean the machine thoroughly. Clean each cylinder rod (plated areas) and the radiator with extra care.

**IMPORTANT:** Take care not to spray water directly to electrical parts except for kinds of lights such as the headlights, work lights, and turn signal lights.

- 4.2 After positioning the machine for storage, carefully coat each cylinder rod (plated areas) and the control valve spools with rust-preventive oil.
- 4.3 Lubricate all pins while referring to A Greasing Section in the Maintenance Guide List.

**CAUTION:** When removing the batteries, first disconnect the ground cable from the battery terminal.

- 4.4 Remove the batteries and store them in a dry cool place. When the batteries are not removed, disconnect the ground terminal cable.

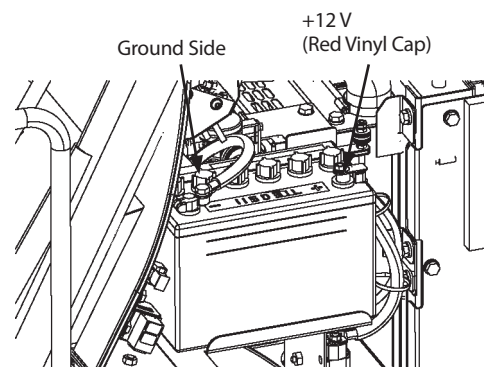

MNBC-05-001

## OPERATING THE MACHINE

---

---

### MEMO

A series of horizontal dotted lines for taking notes.

# TRANSPORTING

## Transporting by Road

When transporting the machine on public roads, be sure to first understand and follow all local regulations.

- For transporting using a trailer, check the width, height, length and weight of the trailer when the machine is loaded.
- Investigate beforehand the conditions of the route to be traveled, such as dimensional limits, weight limits, and traffic regulations. In some cases, getting approval from the authority concerned, disassembling the machine to bring it within dimensional limits or weight limits of local regulations may be necessary.

## Transporting by Trailer

Provide an appropriate trailer while referring to the weight and dimensions shown in the specifications. When transporting the machine within the weight and dimensions shown in the specifications by a trailer, it is possible to transport the machine without disassembling.

## Loading/Unloading on Trailer

**⚠ WARNING:** Be sure to use a loading dock or a ramp for loading/unloading.

Always load and unload the machine on a firm, level surface.

### Ramp/Loading Dock:

1. Before loading, thoroughly clean the ramps, loading dock and flatbed. Dirty ramps, loading docks, and flatbeds with oil, mud, or ice on them are slippery and dangerous.
2. Place blocks (1) against the trailer wheels so that the trailer does not move while using a ramp or loading dock.
3. Ramps must be sufficient in width, length, and strength. Be sure that the incline of the ramp is less than 15 degrees.
4. Loading docks must be sufficient in width and strength to support the machine and have an incline of less than 15 degrees.

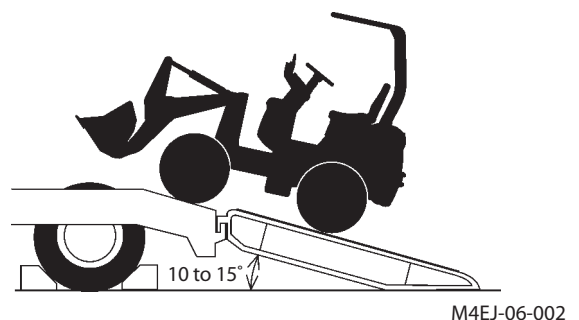
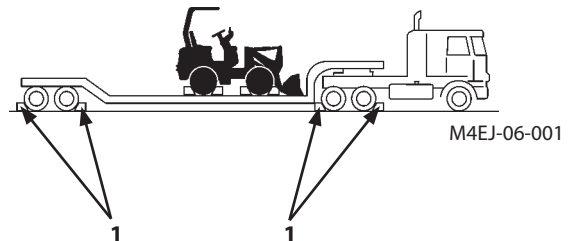

## TRANSPORTING

---

### Loading/Unloading

**⚠ CAUTION:** Pay attention to the following points:

- **Steering on a ramp is hazardous. Never attempt to steer the machine on a ramp. Personal injury or death may result due to loss of machine stability. If the travel direction must be changed on a slope, back machine to flat ground. Then, after changing the travel direction, begin to move again.**

### Loading

1. Load the machine so that the machine width center aligns with the trailer deck width center.
2. Slowly drive the machine on the ramp.
3. Lower the bucket onto the trailer deck.
4. Stop the engine. Remove the key from the key switch.
5. Operate the loader control lever several strokes to relieve pressure in the cylinders.
6. Place the loader control lever lock in the LOCK position.
7. Securely close the windows and cab door to protect the cab from rain. Put a cover over the opening of the exhaust pipe.
8. Install the articulation lock bar (1) to prevent the machine from articulating.

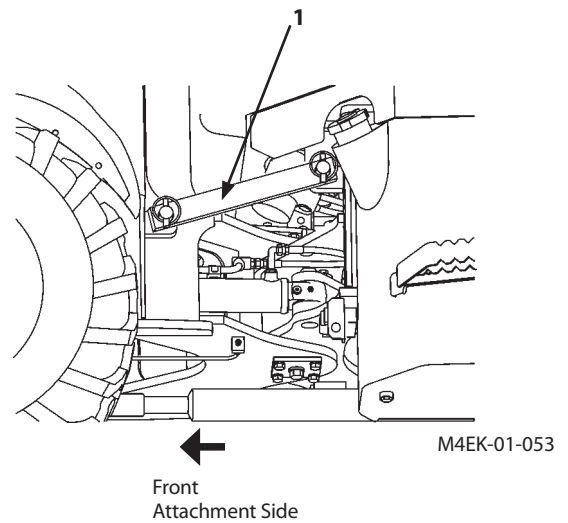

## TRANSPORTING

### Transporting

- CAUTION:** Securely fasten the machine to the trailer flatbed with appropriate accessories (wire ropes/ chains, tighteners.)  
Do not use the optional lifting tools.

The machine may move back and forth and/or laterally during transportation.

1. Apply the parking brake. Slowly rest the bucket on the trailer deck or load-carrying platform.
2. Chock securely (1) behind each tire to fasten the machine in position.
3. Securely fasten the machine to the truck or trailer platform using appropriate accessories (wire ropes/ chains, tighteners...)
4. Respect following safety way of fastening using tie down points:

**NOTE:** When transporting the machine, it is necessary to cover the exhaust pipe to prevent entry of anything into the exhaust system.

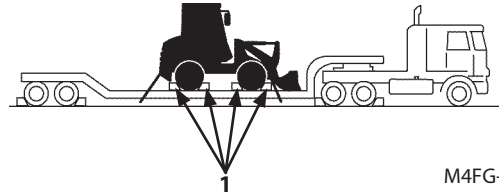

M4FG-06-001

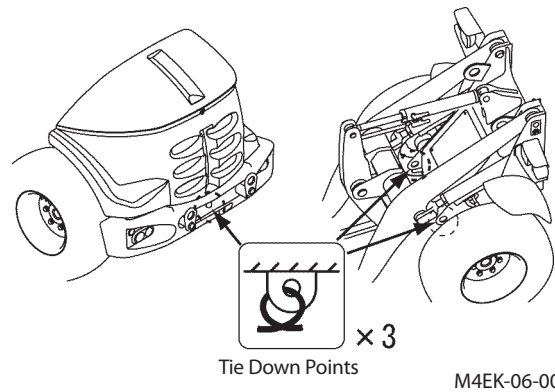

M4EK-06-004\_E

## TRANSPORTING

---

### **Transporting Wheel Loader (Urgent Situation)**

The following procedures shall only be applied to cases when urgently moving the wheel loader a short distance is required. When required to transport the wheel loader long distance, use a trailer.



## TRANSPORTING

### Precautions for Towing

**⚠ WARNING:** Never attempt to tow the machine if the brake system is in need of repair. Ask your nearest authorized dealer to repair the machine. Operate the machine only after repairs is completed.

Avoid towing the machine as much as possible. If the machine is to be unavoidably towed, beware of the following points.

**IMPORTANT:** Do not tow the machine with the parking brake applied. Damage to the parking brake may result.

- When the engine is operable:  
Keep the engine running to maintain the steering and brake systems operable and then, release the parking brake.
- If the engine is inoperable:  
It is possible for the machine to be towed in either (a) or (b) of the following methods.
  - (a) Remove both front and rear propeller shafts. (Refer to the "Removal of Propeller Shafts" on page 6-6.)
  - (b) Relieve the HST hydraulic pressure. (Refer to the "Relieving HST Oil Pressure" on page 6-7.) As it is impossible for the parking brake to be released, manually release the parking brake. (Refer to the "Releasing Parking Brake" on page 6-8.)

In case the bucket is being rested on the ground, raise the bucket above the ground following the procedures below.

1. Place loader control lever (1) in FLOAT position (c).
2. Using a jack or a crane, lift the bucket or the lift arm.
3. Move loader control lever (1) to NEUTRAL position (N) and loader control lever lock (2) to LOCK position (3) to maintain the bucket in position above the ground.

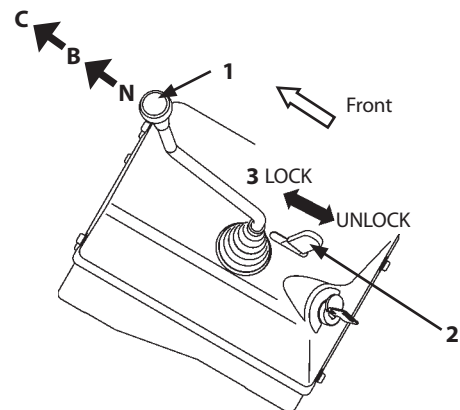

M4EK-06-001

## TRANSPORTING

### Removal of Propeller Shafts

**⚠ WARNING:** After removing the propeller shafts, the machine becomes impossible to stop even if the brake system is activated, possibly resulting in personal injury or death. Before removing or installing the propeller shafts, chock the tires.

The propeller shafts are removed only when the machine must be towed with the engine inoperable.

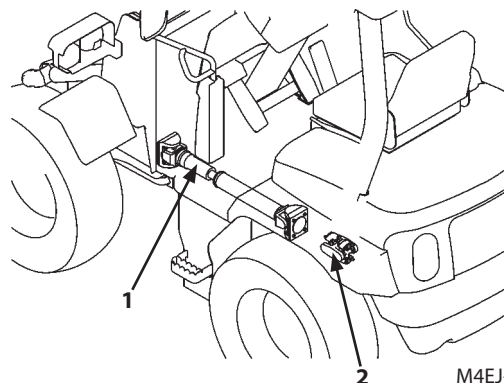

### Procedures

**⚠ WARNING:**

- Before removing the propeller shafts, chock the tires to prevent the machine from moving.
- Before operating the machine again after reinstalling the propeller shafts, have the machine checked by your nearest authorized dealer.

1. Remove front propeller shaft mounting bolts (3) (8 used) to remove front propeller shaft (1) from the front axle and the transmission.
2. Remove rear propeller shaft mounting bolts (4) (8 used) to remove rear propeller shaft (2) from the rear axle and the transmission.
3. After towing the machine, reinstall front propeller shaft (1) and rear propeller shaft (2) to their original positions. Refer to "Nuts and Bolts to be Retightened" in the Maintenance section for the tightening torque values of bolts (3) and (4).

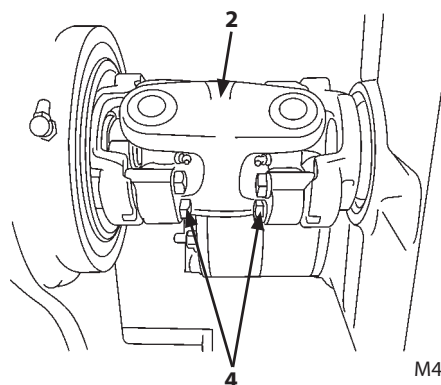
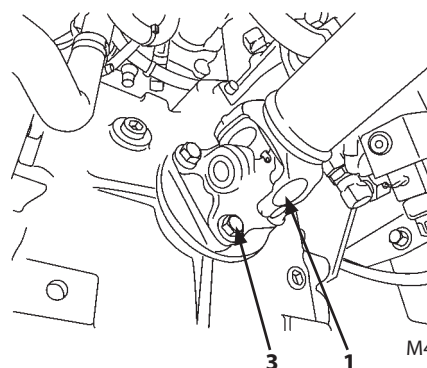
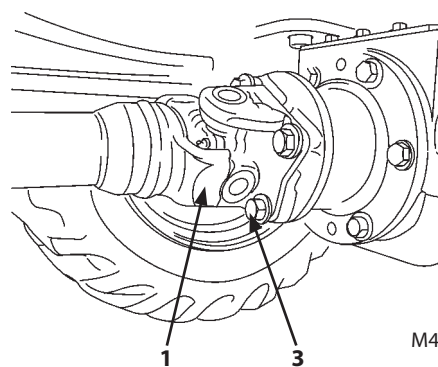

## TRANSPORTING

### Relieving HST Hydraulic Pressure

**CAUTION:** Do not tow the machine at travel speed faster than 2 km/h and in a distance longer than 1 km (0.6 mile). The HST hydraulic pressure must be reset to the original set pressure after towing is complete. Contact your nearest authorized dealer and have the machine inspected and serviced.

### Procedures

The HST hydraulic pressure is manually relieved only when the machine must be towed with the engine inoperable.

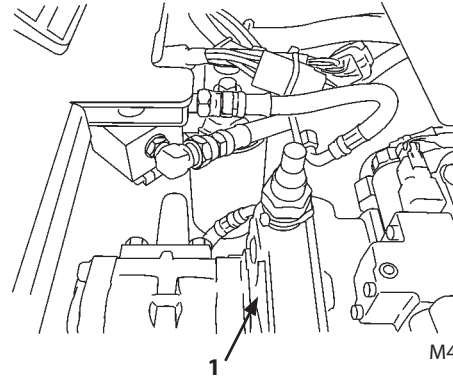

M4EJ-06-007

### WARNING:

- Before relieving the HST hydraulic pressure, chock the tires to prevent the machine from moving.
  - Before operating the machine again after resetting the HST hydraulic pressure, have the HST system readjusted by your nearest authorized dealer.
1. If required to tow the machine with the engine inoperable, the hydraulic pressure in the HST pump/motor closed circuit must be relieved.
  2. Remove the floor mat and the maintenance access cover from the base of the operator's seat. Wait for HST pump (1) to cool until it becomes touchable with a bare hand.
  3. Remove caps from two high pressure relief valves on HST pump (1). Loosen lock nuts (2). Tighten adjust screws (hexagon socket head) (3) until the screw head becomes flush with the top surface of lock nuts (2).
  4. Tighten lock nuts (2).
  5. After towing is complete, return adjust screws (hexagon socket head) (3) to their original position and secure with lock nuts (2).

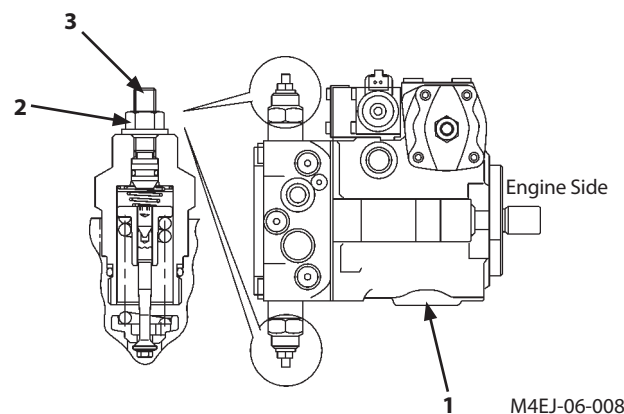

M4EJ-06-008

## TRANSPORTING

### Releasing Parking Brake

**⚠ WARNING:** Once the parking brake is released, the machine becomes impossible to stop with the parking brake system, possibly resulting in personal injury or death. Before releasing the parking brake, securely chock the tires.

**⚠ CAUTION:** As soon as towing operation is complete, connect the parking brake. Moving the machine by means of towing shall be made in a short distance until the machine reaches an appropriate location for inspection and/or maintenance. Do not tow the machine for a long distance.

Manually releasing the parking brake should only be done when the parking brake switch becomes inoperable due to any abnormality or failure in the brake system such as a pump.

### Procedures

**⚠ WARNING:**

- Once the parking brake is manually released, the machine braking system is completely deactivated.
- Before releasing the parking brake manually, securely chock all tires to prevent the machine from moving.
- Before operating the machine again after releasing the parking brake manually, have the parking brake readjusted by your nearest authorized dealer.

1. Remove plug (1) from the brake cover center.
2. Remove brake release bolt (2) from the brake cover.
3. Install brake release bolt (2) in plug (1) hole.
4. Tighten brake release bolt (2) to pull out parking brake piston (3).
5. After the head of brake release bolt (2) comes in contact with the brake cover, tighten brake release bolt (2) over 2 more turns to release the parking brake.

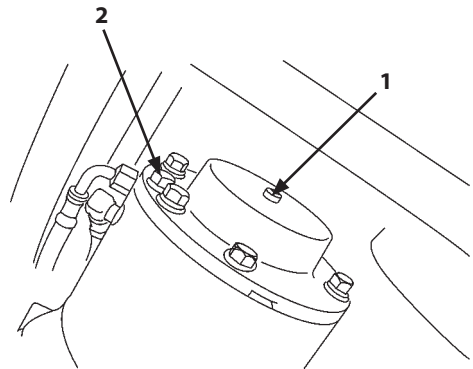

M4EJ-06-005

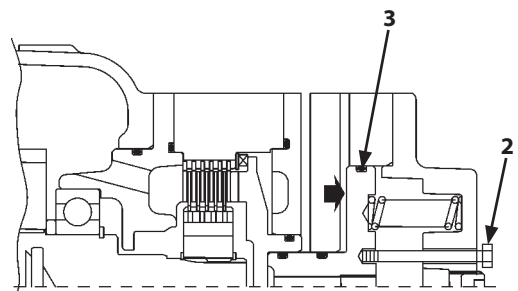

M4EJ-06-006

## TRANSPORTING

### Towing Method

**⚠ CAUTION:** Use wire rope having the strength more than approx. 150 % of the machine weight.

- Towing from the front side of the machine;

When using wire ropes, be sure to attach wire ropes to the front frame. Always use soft material at the corners between the front frame and wire ropes to prevent damage to wire ropes.

- Towing from the rear side of the machine;

Be sure to attach wire ropes to the drawbar pin. Always use the lock pin after completely inserting the drawbar pin to prevent the wire rope from coming off.

- Do not use the optional lifting tools for towing.

Attach wire ropes to the machine as illustrated when the machine must be unavoidably towed, such cases when the machine cannot be removed from soft ground under its own power.

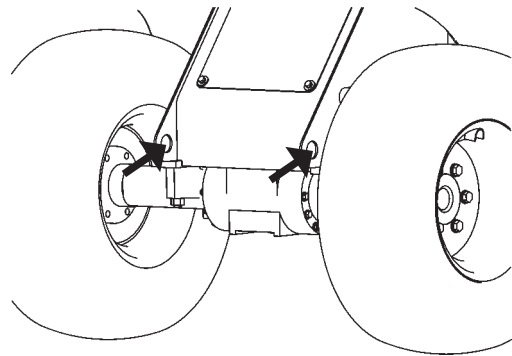

M4EK-06-002

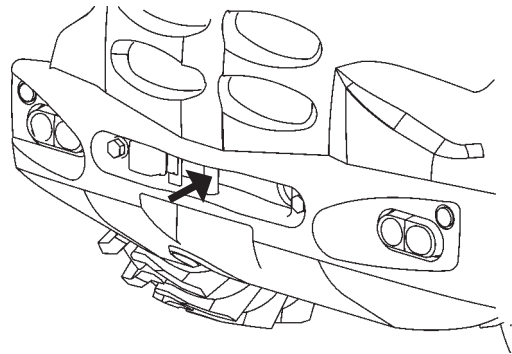

M4EK-06-003

# TRANSPORTING

## Lifting Machine

**⚠ WARNING:** Pay attention to the following points:

- The lifting tools are option. Install specific lifting tools at your nearest authorized dealer.
- Use lifting cables and other lifting tools free from any damage and/or aging, and having sufficient strength.
- Use lifting points as shown in figure.
- Consult your nearest authorized dealer for correct lifting procedures, and size and types of lifting cable and tools.
- Before lifting the machine, move the load-handling lever lock to the LOCK position to prevent the machine from moving unexpectedly.
- Rigidly secure the front and rear frames using the articulation lock bar so that the machine front and rear frames can not articulate.
- If the machine is incorrectly lifted or if lifting wire ropes are incorrectly attached to the machine, the machine may move when lifted, possibly resulting in an accident and/or damage to the machine.
- Never apply impact loads to the lifting cables and tools.
- Do not allow anyone to enter the area under the lifted machine.

### Lifting

1. Position the front attachment as illustrated to the right.
2. Move the loader control lever lock to the LOCK position.
3. Rigidly secure the front and rear frames using the articulation lock bar.
4. Stop the engine. Remove the key from the key switch.
5. Use cables long enough so that the cables come in contact with the machine chassis when the machine is lifted. Cover the cables with cloth as needed to protect the machine from being damaged. Be sure to use the specified lifting tools.
6. Set a crane in an appropriate position.
7. Attach the cable to the front attachment and the lifting tools.

**🔩 NOTE:** The rear lifting tools are optional hooks to be installed for the lifting purpose only. The hook must be securely tighten with mounting bolts and washers to the specified torque [423 to 460 N-m].

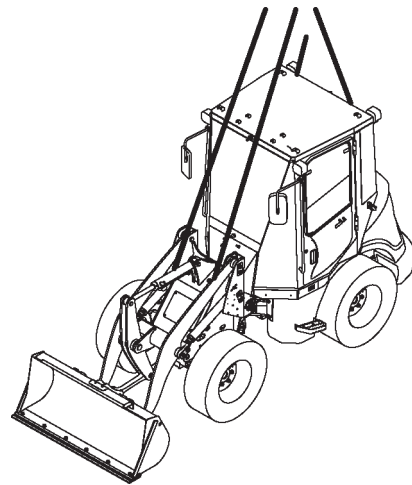

M4EJ-05-021

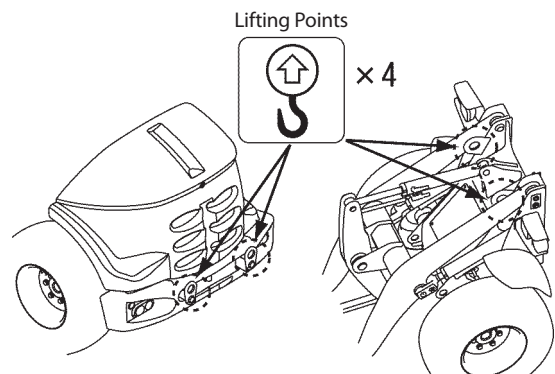

M4EK-06-005\_E

## MAINTENANCE

---

### Correct Maintenance and Inspection Procedures

Learn how to service your machine correctly. Follow the correct maintenance and inspection procedures shown in this manual. Refer to page 3-1 for walk around inspection list.

Inspect machine daily before starting.

- Check controls and instruments.
- Check coolant, fuel and oil levels.
- Check for leaks, kinked, frayed or damaged hoses and lines.
- Walk around machine checking general appearance, noise, heat, etc.
- Check for loose or missing parts.

If there is any problem with your machine, repair it before operating or contact your authorized dealer.

#### IMPORTANT:

- **Use only recommended fuel and lubricants.**
- **Be sure to use only genuine Hitachi parts. Failure to do so may result in serious injury or death and/or machine breakdown.**
- **Use only genuine Hitachi parts.**
- **Failure to use recommended fuel, lubricants, and genuine Hitachi parts will result in loss of Hitachi product warranty.**
- **Never adjust engine governor or hydraulic system relief valve.**
- **Protect electrical parts from water and steam.**
- **Never disassemble electrical components such as main controller, sensors, etc.**



SA-005

## MAINTENANCE

---

### Check the Hour Meter Regularly

- Intervals on the periodic maintenance chart are for operating in normal conditions. If you operate your machine in more adverse conditions, you should service it at SHORTER INTERVALS.
- Lubricate, make service checks and adjustments at intervals shown on periodic maintenance guide table (see page 7-4).

### Use Correct Fuels and Lubricants

**IMPORTANT:** Always use recommended fuels and lubricants.

**Failure to do so will result in machine damage and loss of Hitachi product warranty.**



# MAINTENANCE

## Layout

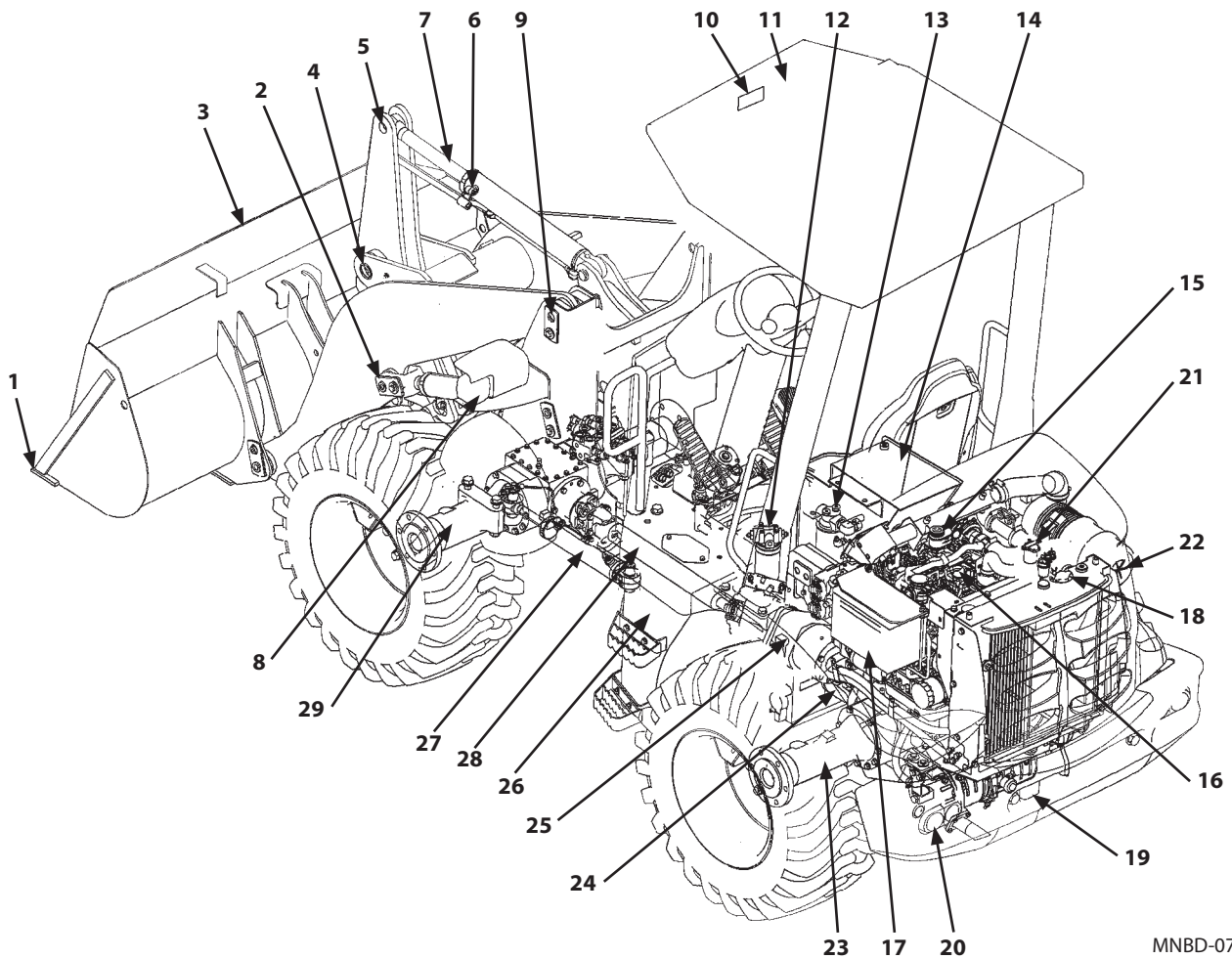

MNBD-07-001

- |                                       |                            |
|---------------------------------------|----------------------------|
| 1- Cutting edge                       | 16- Engine                 |
| 2- Lift arm cylinder rod pin          | 17- Battery                |
| 3- Bucket                             | 18- Radiator/Oil cooler    |
| 4- Bell crank pin                     | 19- Backup light           |
| 5- Bucket cylinder rod pin            | 20- Rear combination light |
| 6- Bucket auto-leveler                | 21- Fuel filter            |
| 7- Bucket cylinder                    | 22- Air cleaner            |
| 8- Head light/Front combination light | 23- Rear axle              |
| 9- Lift arm pin                       | 24- Rear propeller shaft   |
| 10- Rear view mirror                  | 25- Transmission           |
| 11- ROPS Canopy                       | 26- Fuel tank              |
| 12- HST oil filter                    | 27- Steering cylinder      |
| 13- Return filter                     | 28- Front propeller shaft  |
| 14- Hydraulic oil tank/Suction filter | 29- Front axle             |
| 15- Brake oil tank                    |                            |

# MAINTENANCE

## Maintenance Guide Table

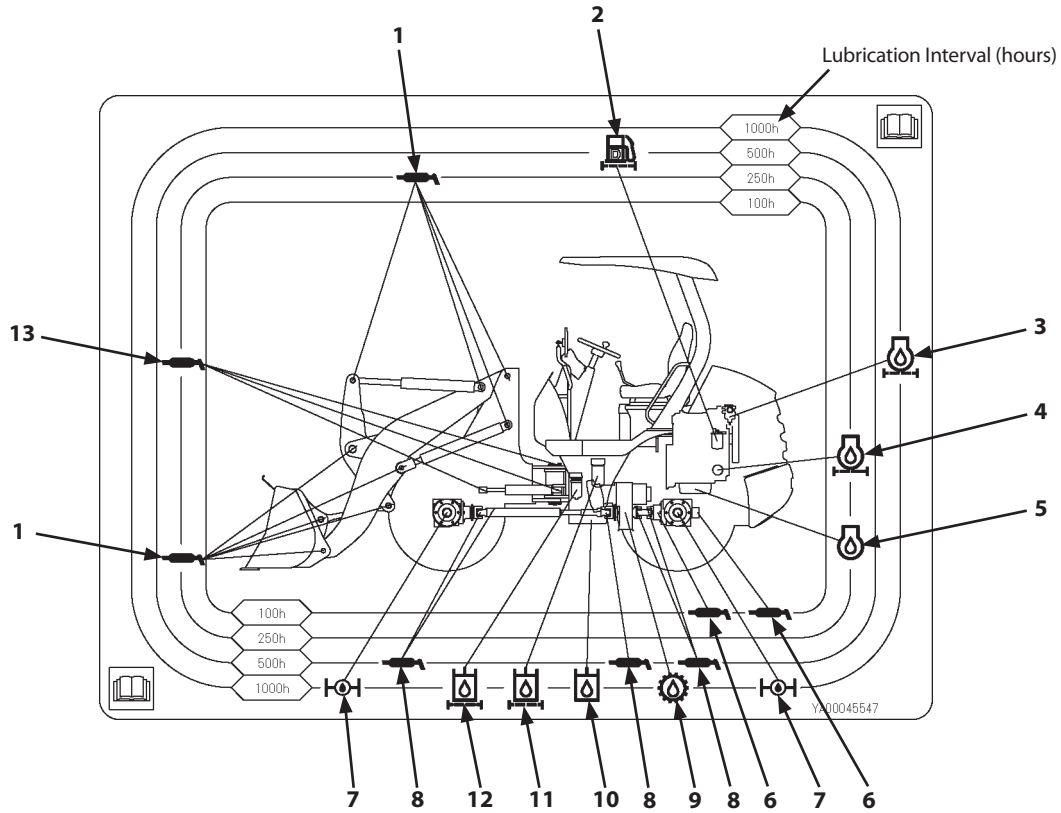

MNBC-07-001

Item	Page	Item	Page
1 Grease (Front Joint Pins)	7-18	8 Grease (Propeller Shaft)	7-21
2 Main Fuel Filter	7-47	9 Transmission Oil	7-26
3 Oil Separator (Blow-by Gases)	7-25	10 Hydraulic Oil	7-33
4 Engine Oil Filter	7-24	11 Hydraulic Oil Filter (Return)	7-38
5 Engine Oil	7-23	12 HST Oil Filter	7-36
6 Grease (Axle Support Pin)	7-20	13 Grease (Frame Center Hinge Pin)	7-20
7 Axle Oil (Final reduction gear, differential)	7-27		

## MAINTENANCE

### Preparations for Inspection and Maintenance

**CAUTION:** If the machine is unexpectedly moved, a serious accident may result. Be sure to apply the parking brake when parking the machine.

Unless especially specified, park the machine by following the procedures below before beginning the inspection and/or maintenance work.

1. Park the machine on solid level surface.
2. Lower the working tools such as the bucket to the ground.
3. Place forward/reverse selector lever (1) in neutral and place neutral lever lock (2) to LOCK position (3).
4. Apply the parking brake [Turn parking brake switch (4) ON.]
5. Chock the tires.
6. Turn the key switch (5) OFF and stop the engine. Remove the key from the switch. Fully move loader control lever (6) 3 to 4 strokes to release residual pressure in the hydraulic system.
7. Be sure to place loader control lever lock (7) in the LOCK position (8).
8. Begin to work only after attaching a "UNDER INSPECTION/MAINTENANCE" tag in a highly visible place such as on the cab door or loader control lever (6).

**WARNING:** Never attempt to maintain the machine when the engine is running in order to prevent the accident. If the engine must be run while working, do the following.

- One person should take the operator's seat to be ready to stop the engine any time while communicating with other workers.
- When working around moving parts is unavoidable, pay special attention to ensure that hands, feet, and clothing do not become entangled.
- If parts or tools are dropped or inserted into the fan or the belt, they may fly off or be cut off. Do not drop or insert parts and tools into the moving parts.
- Move loader control lever lock (7) to lock position (8) so that the front attachment will not move.
- Never touch the control levers and pedals. If operating the control levers or pedals is unavoidable, signal co-workers to move to a safe place.



M4EK-07-002

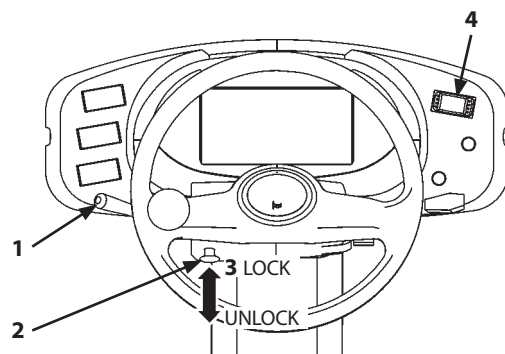

MNBC-04-002

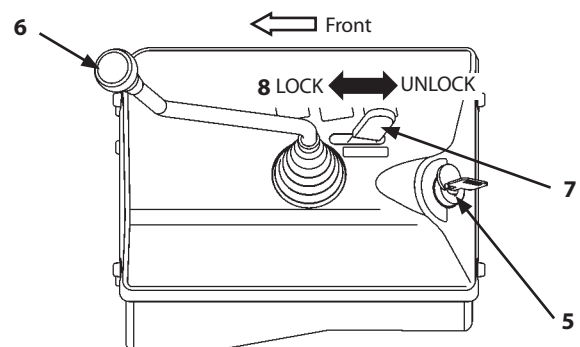

M4EK-01-061

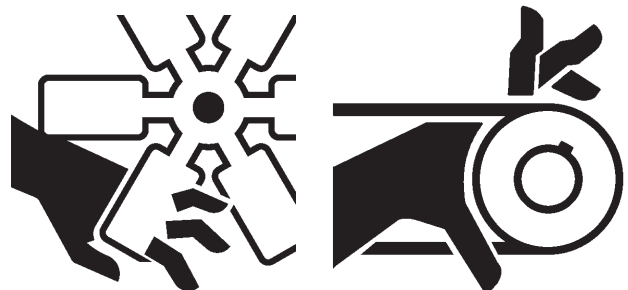

SA-2294

SA-026

## MAINTENANCE

### Lock Frames

**⚠ CAUTION:** Before beginning to work near the frame axle, install articulation lock bar (1) to securely lock and prohibit movement between the front and rear frames (3) and (4). Avoid accidents due to unexpected movement of the machine.

1. Align the front and rear frame (3) and (4) centers with each other.
2. Remove lock pin (2) and remove articulation lock bar (1) from the hole on front frame (3).
3. Install one end of articulation lock bar (1) into the hole on rear frame (4). Secure articulation lock bar (1) in position with lock pin (2).

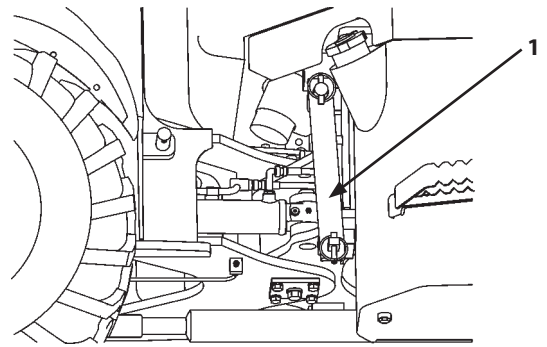

M4EK-01-052

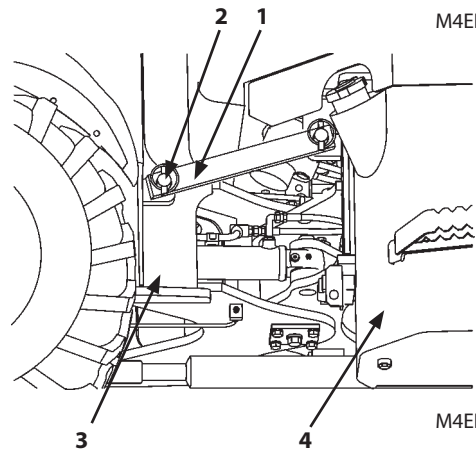

M4EK-01-053

## MAINTENANCE

### Engine Hood

**⚠ WARNING:** Open/close engine hood (1) only after stopping the engine. Failure to do so may create a very dangerous situation such as entanglement. Before traveling the machine, check that engine hood (1) does not open.

#### Opening/Closing of Engine Hood

- Canopy equipped machine
  1. Press lock key (2) to unlock engine hood (1).
  2. While supporting engine hood (1), slowly raise the engine hood.
  3. When closing engine hood (1), slowly lower the engine hood while supporting the engine hood until a click sound is heard.

**✎ NOTE:** Engine hood (1) can be locked with a key.

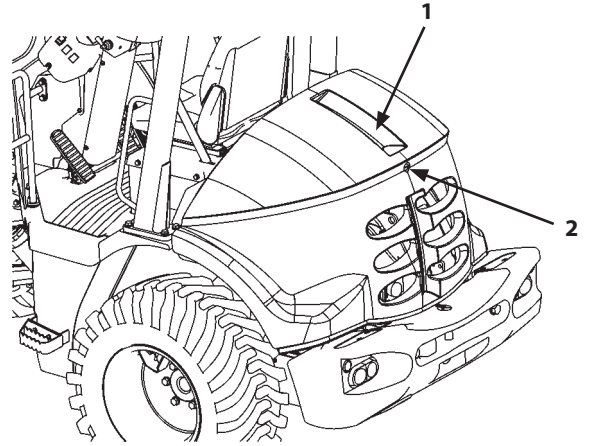

M4ER-01-004

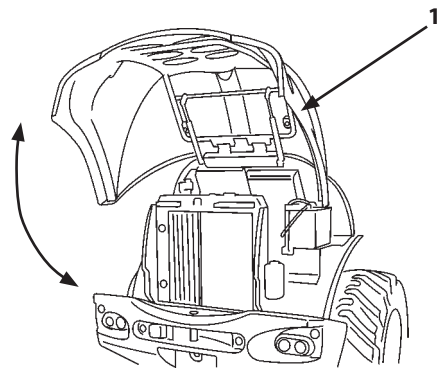

M4EK-01-056

## MAINTENANCE

---

### Periodic Replacement of Parts

To ensure safe operation, be sure to conduct periodic inspection of the machine. In addition, the parts listed below, if defective, may pose serious safety/fire hazards. It is very difficult to gauge the extent of deterioration, fatigue, or weakening of the parts listed below simply by visual inspection alone. For this reason, replace these parts at the intervals shown in the table below. However, if any of these parts are found to be defective, replace before starting operation, regardless of the interval.

Also, when replacing hoses, check the clamps for deformation, cracks, or other deterioration, and replace as necessary.

Be sure to perform periodic inspection of all hoses, as shown below, and replace or retighten any defective parts found, as necessary.

Consult your authorized dealer for correct replacement.

System/Equipment		Replacement Part	Interval
Engine	Fuel Tank	Hose	Every 2 years
Brake system	Brake valve	Various seals (Rubber parts)	Every 1 year
	Wet brake	Piston D-ring	Every 4 years
	Brake piping	Hose	Every 2 years
	Stop light	Switch	Every 2 years
Steering system	Steering piping	Hose	Every 2 years
	Steering cylinder	Various seals (Rubber parts)	Every 4 years
	Steering valve	Various seals (Rubber parts)	Every 2 years
Hydraulic System	Pump	Suction hose Delivery hose	Every 4 years
	Working system	Bucket cylinder line hoses Lift arm cylinder line hose Hydraulic oil tank return hose Hydraulic oil cooler line hose	Every 4 years
Operator's Seat	Seat belt	Seat belt	Every 3 years

 **NOTE:** When replacing hoses, replace O-rings, gaskets used for them at the same time.

## MAINTENANCE

### Maintenance Guide

Perform maintenance of items at the intervals shown by the shadowed areas in the table below.

#### A. Greasing

Parts	Quantity	Intervals (Hours)					
		10 Daily	50 -	100 1 Month	250 3 Months	500 6 Months	1000 1 Year
Bucket pin	2	★			★★		
Bucket link pin	2	★			★★		
Bucket cylinder pin	1	★			★★		
Bucket cylinder rod pin	1	★			★★		
Bell crank pin	1	★			★★		
Lift arm cylinder rod pin	2	★			★★		
Lift arm cylinder pin	2	★			★★		
Lift arm pivot pin	2	★			★★		
Steering cylinder pin	1	★			★★		
Steering cylinder rod pin	1	★			★★		
Frame center hinge pin	1				★★		
Rear axle support pin	2						
Front propeller shaft universal	1					★★★	
Front propeller shaft spline	1					★★★	
Rear propeller shaft universal	2					★★★	

- ★: Add grease daily during first 50 hours of operation. In case the machine is engaged in excavation in mud, water or snow, add grease after each work shift.
- ★★: After 50 hours of operation, add grease every 250 hours or every 3 months of operation. Shorten greasing intervals when the machine is operated under severe working conditions or when the machine is continuously operated for a long period of time.
- ★★★: Shorten greasing intervals when the machine is operated under severe working conditions or when the machine is continuously operated for a long period of time.

## MAINTENANCE

### B. Engine

**IMPORTANT:** Be sure to use the specified oil. Change oil at the exactly specified intervals. If unspecified oil is used, or the oil change intervals are arbitrarily extended, serious engine failure or damage may result.

Parts		Quantity	Intervals (Hours)					
			10	50	100	250	500	1000
			Daily	-	1 Month	3 Months	6 Months	1 Year
1. Engine oil	Oil level check	-						
2. Engine oil	Change	5.6 L			★			
3. Engine oil filter	Replace	1			★	★★		
4. Oil Separator (Blow-by Gases)	Replace	1						

★: Only first time at every 100 hours or 1 month.

★★: Replace the engine oil filter when changing engine oil.

### C. Power Train

**IMPORTANT:** Be sure to use the specified oil. Change oil at the exact specified intervals. If unspecified oil is used, or the oil change intervals are arbitrarily extended, serious transmission and/or axle failure or damage may result.

Parts		Quantity	Intervals (Hours)					
			10	50	100	250	500	1000
			Daily	-	1 Month	3 Months	6 Months	1 Year
1. Change transmission oil		1.5 L				★		
2. Axle oil	Change (Front/Rear)	4.5 L				★		
3. Clean transmission air breather		1						
4. Check oil leaks around axle and/ or cover		-						
5. Clean axle housing air breather		1 each in front and rear						

★: Only first time at every 250 hours or 3 months.



## MAINTENANCE

### D. Hydraulic System

**IMPORTANT: Be sure to use the specified oil. Change oil at the exact specified intervals. If unspecified oil is used, or the oil change intervals are arbitrarily extended, serious hydraulic system failure or damage may result.**

Parts	Quantity	Intervals (Hours)					
		10	50	100	250	500	1000
		Daily	-	1 Month	3 Months	6 Months	1 Year
1. Check oil level in hydraulic oil tank	-						
2. Change hydraulic oil/Clean hydraulic oil tank	38 L						
3. Clean suction filter	1	(When changing hydraulic oil)					
4. Replace HST oil filter element	1			★			
5. Replace return filter	1			★			
6.	Check hoses and lines for leaks and tightness	-					
	Check hoses and lines for cracks and bends	-					

★: Only first time at every 100 hours or 1 month.

### E. Fuel System

**IMPORTANT: Be sure to use the specified oil. Engine failure or damage may result.**

Parts	Quantity	Intervals (Hours)					
		10	50	100	250	500	1000
		Daily	-	1 Month	3 Months	6 Months	1 Year
1. Check fuel level in fuel tank	-						
2. Drain water/sediment from fuel tank	1						
3. Check fuel filter and drain water	1						
4. Clean and replace fuel filter element	1			★			
5. Clean water separator screen	1						
6.	Check fuel hoses for leaks and cracks	-					
	Check hoses for cracks and bends	-					

★: Clean the element after 100 hours or 1 month of operation.

### F. Air Cleaner

Parts	Quantity	Intervals (Hours)						
		10	50	100	250	500	1000	
		Daily	-	1 Month	3 Months	6 Months	1 Year	
1. Air cleaner element	Clean	1	When indicator (eye-inspection type) comes ON					
	Replace	1	After cleaning 6 times or once per year					

## MAINTENANCE

### G. Cooling System

**IMPORTANT:** Be sure to use the specified LLC. Change LLC at the exact specified intervals. If unspecified LLC is used, or the LLC change intervals are arbitrarily extended, serious engine failure or damage may result.

Parts	Quantity	Intervals (Hours)					
		10	50	100	250	500	1000
		Daily	-	1 Month	3 Months	6 Months	1 Year
1. Check coolant level	-						
2. Check drive belt	-						
3. Check drive belt tension	-						
4. Adjust Drive belt tension	-						
5. Change coolant	4.5 L						
6. Clean radiator and oil cooler	-				(Or when clogged)		

### H. Electrical System

Parts	Quantity	Intervals (Hours)					
		10	50	100	250	500	1000
		Daily	-	1 Month	3 Months	6 Months	1 Year
1. Check monitor for malfunction and all instruments for inoperativeness	-						
2. Check all lights for abnormality in lightning and/or blinking	-						
3. Check horn, backup buzzer and backup light for malfunction	-						
4. Check electrical circuits and fuses for abnormality	-						
5. Check electrolyte level	1						
6. Check electrolyte specific gravity	1						

### I. Brake System

**IMPORTANT:** Be sure to use the specified oil (mineral oil). Change oil at the exact specified intervals. If an unspecified oil (vegetable oil) is used, or the oil change intervals are arbitrarily extended, serious brake failure or damage may result.

Parts	Quantity	Intervals (Hours)					
		10	50	100	250	500	1000
		Daily	-	1 Month	3 Months	6 Months	1 Year
1. Check brake oil level	-		Indicator comes ON				
2. Check right and left brake interlock control performance	-						
3. Check parking brake force	-						
4. Check brake discs (service and parking for abnormality)	-						
5. Change brake oil	0.35 L						

## MAINTENANCE

### J. Tire

Parts		Quantity	Intervals (Hours)					
			10	50	100	250	500	1000
			Daily	-	1 Month	3 Months	6 Months	1 Year
1. Adjust tire pressure	Check	4						
	Adjust	4	As needed					
2. Check tires for damage	Check	4						
3. Check wheel bolt tightening torque	Retighten	4		★				

★: Only first 50 hours

### K. Air Conditioner

Parts		Quantity	Intervals (Hours)					
			10	50	100	250	500	1000
			Daily	-	1 Month	3 Months	6 Months	1 Year
Air Conditioner	1. Circulation air filter	Cleaning				★		
		Replace		Every 6 months				
	2. Check air conditioner unit	-	Every 6 months					
	3. Check pipelines	-	Every 6 months					
	4. Check air conditioner condenser	1	Every 6 months					
	5. Check air conditioner drive belt	1	Every 6 months					
	6. Check refrigerant quantity	1	Every 6 months					
	7. Check compressor and pulley	1	Once a Year					
8. Check switch operation	-	Once a Year						

★: Clean the element after 250 hours or 1 month of operation.  
When the machine is operated in dusty work site, shorten intervals of cleaning and/or replacement.

Parts		Quantity	Intervals (Hours)					
			10	50	100	250	500	1000
			Daily	-	1 Month	3 Months	6 Months	1 Year
Air Conditioner	1. Check Air Conditioner for Damage		-	Every 6 months				
	2. Check Heater piping		-	Every 6 months				
	3. Circulation air filter	Cleaning					★	
		Replace		Every 6 months				
	4. Check air conditioner unit		-	Every 6 months				
	5. Check pipelines		-	Every 6 months				
	6. Check air conditioner condenser		1	Every 6 months				
	7. Check air conditioner drive belt		1	Every 6 months				
	8. Check refrigerant quantity		1	Every 6 months				
	9. Check compressor and pulley		1	Once a Year				
10. Check switch operation		-	Once a Year					

## MAINTENANCE

### L. Miscellaneous

Parts	Quantity	Intervals (Hours)					
		10 Daily	50 -	100 1 Month	250 3 Months	500 6 Months	1000 1 Year
1. Check bucket bolt-on-cutting edge for tightness and/or wear	-						
2. Check and replace seat belt	1		Every 4 years (Replace)				
3. Check canopy/cab damage and bolt tightness	-						
4. Check windshield washer fluid level	-						
5. Check play amount in steering wheel stroke	-						
6. Check accelerator pedal operation, and exhaust gas color and noise	-						
7. Check rear view mirror and inside rear view mirror for damage and tightness	-						
8. Check steps and hand rails for damage and tightness	-						
9. Clean engine compartment and hood	-						
10. Check and adjust valve clearance*	-						
11. Check sound absorbing mat around engine for damage	-						
12. Check fuel injection timing*	-						★★
13. Check engine compression pressure*	-						★★
14. Check and clean starter and alternator*	-						
15. Retighten front axle and rear axle support mounting bolts	-		★				

 **NOTE:** Contact your nearest authorized dealer for maintenance of items with mark (\*)

★: Only first 50 hours

★★: Every 1000 hours or 1 year whichever come first

## MAINTENANCE

### Kind of Oils

#### Grease

Kind of Grease	Lithium Grease	
Application	Front Joint Pins, etc.	
Air Temperature	-20 to 45 °C (-4 to 113 °F)	
Recommended Product	Hitachi Genuine Grease NLGI EP-2	
Alternative Products	Specification	NLGI 2 EP

#### IMPORTANT:

- **Hitachi Genuine Greases are specially designed and tested to provide optimum performance for Hitachi construction machinery, hence we recommend to use Hitachi Genuine Greases.**
- **Do not use greases which do not meet the above specification or requirements. Use of unsuitable grease may lead to damage which is excluded from Hitachi Warranty Policy.**

#### Engine Oil

Kind of Oil	Engine Oil	
Application	Engine Crank Case	
Air Temperature	-20 to 45 °C (-4 to 113 °F)	
Recommended Product	HITACHI	Hitachi Genuine Engine Oil 10W-40 DH-2
Alternative Products	Specification	JASO DH-2 10W-40

**IMPORTANT: Do not use oils which do not meet the above specification or requirements. Use of unsuitable oil may lead to engine damage which is excluded from Hitachi Warranty Policy.**

 **NOTE:** The machine shipped from factory is filled with engine oil marked with \*. Be careful that oil change intervals will differ according to the standard employed.

#### Transmission Oil

Kind of Oil	Transmission Oil	
Application	Transmission	
Air Temperature	-20 to 40 °C (-4 to 104 °F)	
Recommended Product	JXTG Nippon Oil & Energy	* HDS-3 10W FARM GEAR B
Alternative Products	Specification	Engine Oil 10W Class

 **NOTE:** The machine shipped from factory is filled with transmission oil marked with \*.

#### Brake Oil

Kind of Oil	Torque Converter Oil	
Application	Brake System	
Recommended Product	Idemitsu Kosan	* DAPHNE TORQUE OIL B
Alternative Products	Specification	SAE 5W (Mineral Oil)

 **NOTE:** The machine shipped from the factory is filled with the oil marked with \*. Use the same oil (mineral oil). Use of other oil (vegetable oil) may cause the failure and/or malfunction of the brake.

## MAINTENANCE

### Axle Oil

Kind of Oil		Axle Oil	
Application		Axle	
Recommended Product	Hitachi	High Gear Oil	
		TKTT15150-4th	

#### IMPORTANT:

- **Hitachi Genuine Axle Oils are specially designed and tested to provide optimum performance for Hitachi construction machinery, hence we recommend to use Hitachi Genuine Axle Oils. If other oil is used, which may lead to damage on the machine.**
- **Do not use oils which do not meet the above specification or requirements. Use of unsuitable oil may lead to damage which is excluded from Hitachi Warranty Policy.**

### Hydraulic Oil

Kind of Oil		Hydraulic Oil	
Application		Hydraulic System	
Air Temperature		-20 to 40 °C (-4 to 104 °F)	
Change Interval		1000 hours	*
Recommended Product	Hitachi	Super EX 46HN	-
Alternative Product		-	JCMAS HK VG46W

 **NOTE:** \* A different interval of oil change may be required for Alternative Products. For details, contact your authorized dealer.

#### IMPORTANT:

- **Hitachi Genuine Hydraulic Oils are specially designed and tested to provide optimum performance for the machine, hence we recommend to use Hitachi Genuine Hydraulic Oils.**
- **Do not use oils which do not meet the above specification or requirements. Use of unsuitable oil may lead to damage which is excluded from Hitachi Warranty Policy.**

### Long-Life Coolant

Kind of Coolant	Long-Life Coolant
Application	Radiator
Standard	ASTMD-6210
Manufacturer/Recommended Products	Hitachi Genuine Long Life Coolant

## MAINTENANCE

### List of Consumable Parts

#### 1. Filter Elements

	Part No.
Engine Oil Filter	4454527
Fuel Main Filter	YA00046445
Oil Separator Element (Blow-by Gases)	YA00046446
Air Cleaner Element (outer)	3050211113
Air Cleaner Element (inner)	3050211112
Suction Filter	62J7812112
Return Filter	3367813111
HST Oil Filter	4630525

#### 2. Drive Belts

	Part No.
Cooling Fan Drive Belt	YA00047449
Air Conditioner Compressor Drive Belt	62J1712113

#### 3. Bucket Parts

		Part No.	Quantity
Cutting Edge	Edge	3038119111	1
	Bolt	3218119112	7
	Washer	J222016	7
	Nut	J950016	7

#### 4. Combination Light and Other Light

			Part No.
Front Combination Light	Front Combination Light Assembly		3011365315
	Head Light Assembly		3011365311
	Bulb	Head Light (12V 55W)	3231219819
		Clearance Light (12V 5W)	3221319814
	Turn Signal Light (12V 21W)	3011369814	
Rear Combination Light	Rear Combination Light Assembly		3021215312
	Bulb	Tail/Brake Light (12V 21W/5W)	3021219812
		Turn Signal Light (12V 21W)	3011369814
Backup Light	Backup Light Assembly		62J1215312
	Bulb (12V 21W)		62J1219812
Work Light	Work Light Assembly (LED)		YA00027159

#### 5. Slow Blow Fuses

	Part No.
65A	3231265114

 **NOTE:** The part numbers are subject to change without notice. Refer to the parts catalog.

## MAINTENANCE

### A. Greasing

**CAUTION:** Apply the parking brake and hold the front and rear frames rigidly with the articulation lock bar.

**NOTE:** During break-in operation more than 50 hours until initial operational break-in is finished, grease the machine every day. In case excavations are performed in mud, water or snow, grease the machine after operation is complete.

**NOTE:** Add high quality grease through the grease fittings. After removing contamination around the grease fitting, add grease. After greasing, thoroughly wipe off old grease that was pushed out from the seals.

Bucket Link (1) [Each 1 point on the right and left sides]

--- every 250 hours or 3 months  
[Daily during first 50 hours]

Bucket Link Pins (2) and (3) [1 point on each pin]

--- every 250 hours or 3 months  
[Daily during first 50 hours]

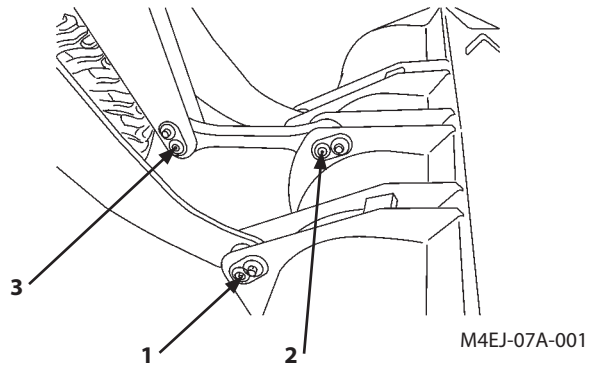

Bucket Cylinder Pin (4) [1 point]

--- every 250 hours or 3 months  
[Daily during first 50 hours]

Bucket Cylinder Rod Pin (5) [1 point]

--- every 250 hours or 3 months  
[Daily during first 50 hours]

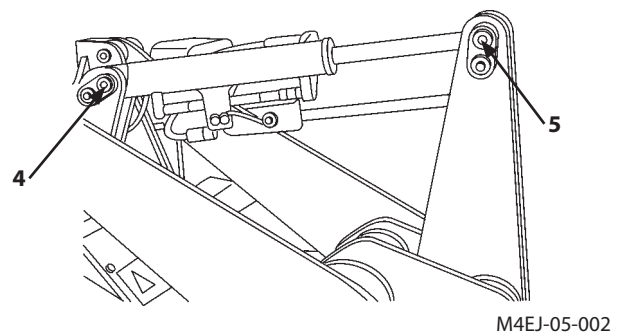



## MAINTENANCE

Bell Crank Pin (6) [1 point]

--- every 250 hours or 3 months  
[Daily during first 50 hours]

Lift Arm Cylinder Rod Pins (7) [Each 1 point on the right and left sides]

--- every 250 hours or 3 months  
[Daily during first 50 hours]

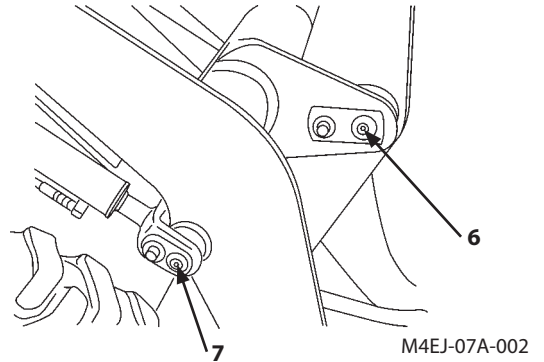

Lift Arm Cylinder Pins (8) [Each 1 point on the right and left sides]

--- every 250 hours or 3 months  
[Daily during first 50 hours]

Lift Arm Pivot Pins (9) [Each 1 point on the right and left sides]

--- every 250 hours or 3 months  
[Daily during first 50 hours]

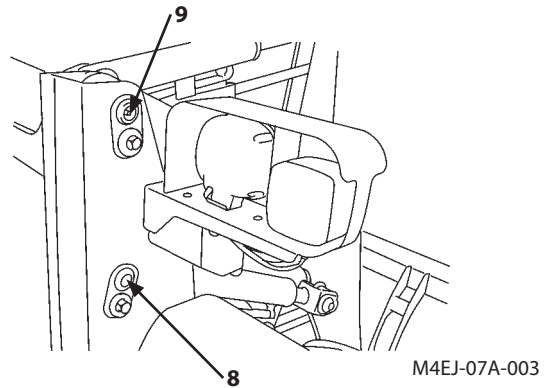

Steering Cylinder Rod Pin (10) [1 point]

--- every 250 hours or 3 months  
[Daily during first 50 hours]

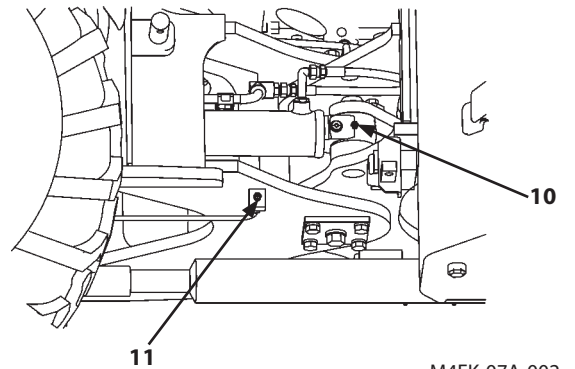

Steering Cylinder Pin (11) [1 point]

--- every 250 hours or 3 months  
[Daily during first 50 hours]

## MAINTENANCE

---

Frame Center Hinge Pin (12) [1 point]  
--- every 250 hours or 3 months

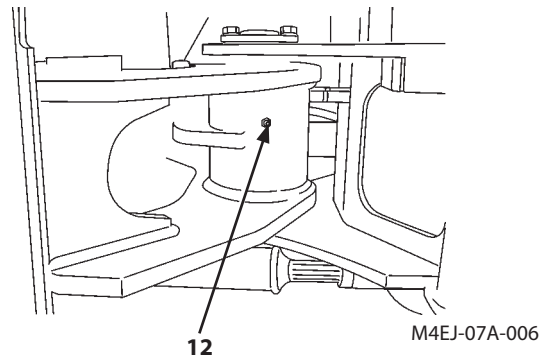

Rear Axle Support Pins (13: Front Pin, 14: Rear Pin) (Each 1 point on the front and rear pins)  
---every 100 hours or 1 month

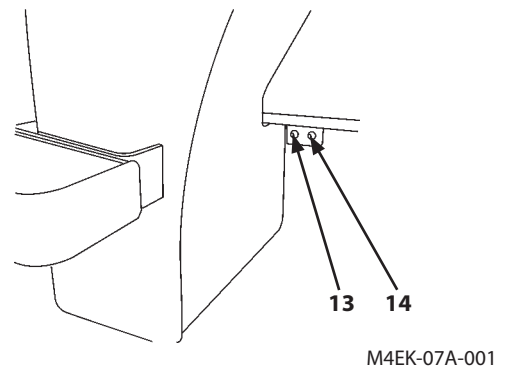

## MAINTENANCE

---

Front Propeller Shaft Universal (15) [1 point]  
--- every 500 hours or 6 months

 **NOTE:** When the machine is continuously operated under severe conditions for a long time, shorten the greasing intervals. In case the machine is operated in mud and/or water, grease the machine after operation is complete.

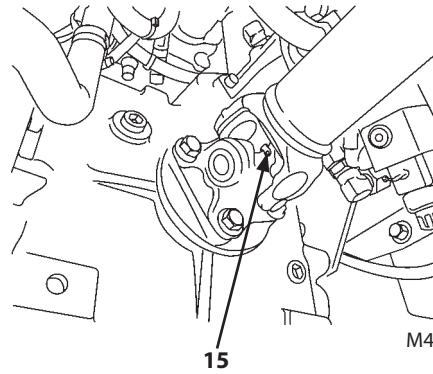

M4EJ-07A-010

Front Propeller Shaft Spline (16) [1 point]  
--- every 500 hours or 6 months

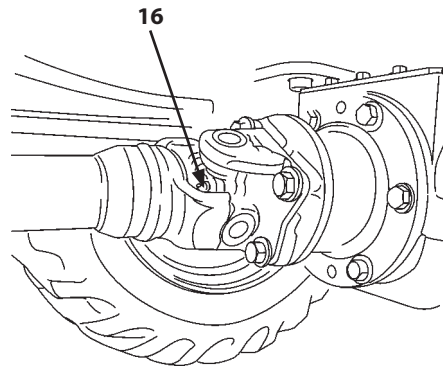

M4EJ-07A-009

Rear Propeller Shaft Universal (17) [2 point]  
--- every 500 hours or 6 months

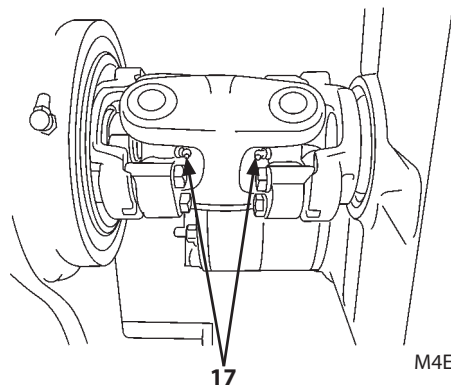

M4EJ-07A-011

## MAINTENANCE

### B. Engine

#### **1** Check Engine Oil Level --- every 10 hours (before starting the engine)

Check the oil level before starting the engine. Remove dipstick (1). Check for mixing of foreign matter or contamination in the oil. Wipe oil off the dipstick with a clean cloth. Reinsert dipstick (1) and remove it again. Read level. Oil level must be within the specified range on dipstick (1). If necessary, add the recommended engine oil via oil filler (2). Recheck oil level after adding the oil.

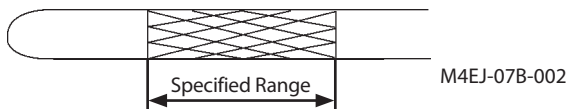

**NOTE:** Before refilling oil or checking the oil level, be sure the machine is level. When checking the oil level after operating the machine, first stop the engine. Wait for more than 15 minutes. Then check the oil level. (This means that the oil level has become stabilized after all oil was delivered to respective lubrication area returns to the oil pan.) In case the oil color changes, severe contamination, and/or mixing of foreign matter is found, change the oil.

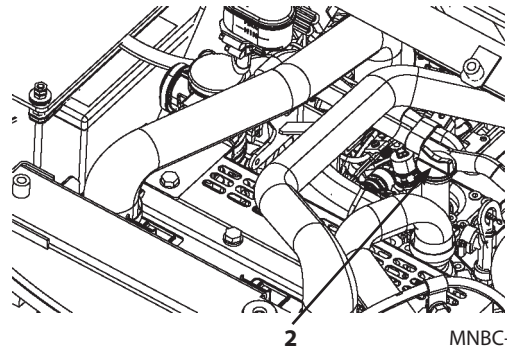
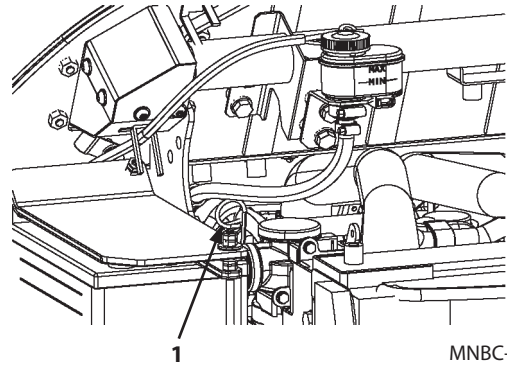

## MAINTENANCE

### 2 Change Engine Oil

--- every 250 hours or 3 months (Only first time at 100 hours or 1 month)

This interval applies only when ultra low sulfur diesel fuel (ULSD) is not used. If ULSD is used (with less than % 0.05 ppm), the oil change interval can be extended to 500 hours.

**⚠ WARNING: Immediately after the machine was operated, all engine parts are hot. Wait for the engine to cool before starting any maintenance work. Failure to do so may cause severe burns.**

**IMPORTANT: Improper disposition of waste oil can threaten the earth environment or ecology. Dispose of the waste oil in accordance with the local regulation and/or law. Be sure to replace the engine oil filter when changing engine oil at the same time.**

1. Park the machine following the same procedures as described on page 7-5 for preparation of inspection/maintenance work.
2. Clean the areas around the drain plug and the oil filter.
3. Arrange 7.6 liter -capacity container to receive the drain oil.
4. Remove drain plug (3) provided behind the rear axle (on the left side of the base machine) to allow oil to drain.
5. Drain oil from the oil filter cartridge.
6. Allow oil to drain through lean cloth to check if any foreign matters such as metal pieces are not included in the oil.
7. Install new oil filter.
8. Securely tighten drain plug (3).
9. Remove the oil filler cap. Supply the specified amount of engine oil.  
Oil refill quantity: 5.6 L
10. Check that the oil level is between the minimum and maximum level scales on the dipstick. Then, start the engine.
11. After starting the engine, check the sealing surfaces for any oil leakage.
12. Allow the engine to run at low idle speed for 5 minutes and stop the engine. About 15 minutes after, check the oil level. If necessary, add oil.

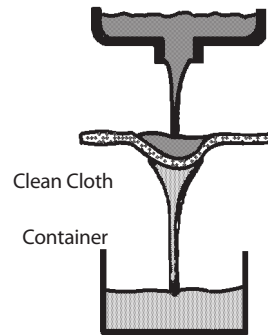

M4GB-07-020

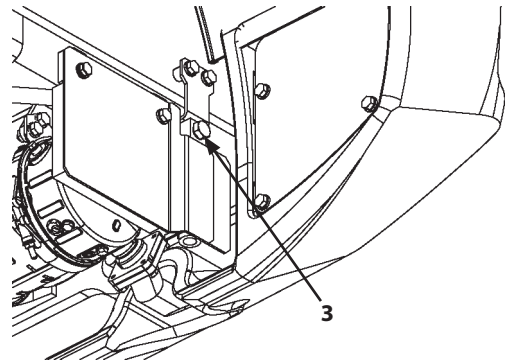

MNBC-07-004

## MAINTENANCE

### 3 Replace Engine Oil Filter

--- every 250 hours or 3 months (Only first time at 100 hours or 1 month)

**WARNING:** Immediately after the machine was operated, all engine parts are hot. Wait for the engine to cool before starting any maintenance work. Failure to do so may cause severe burns.

**NOTE:** Be sure to replace the engine oil filter when changing engine oil at the same time.

1. Park the machine following the same procedures as described on page 7-5 for reparation of inspection/maintenance work.
2. Clean the area around the oil filter.
3. Before removing oil filter (1), loosen drain plug (2) to drain oil from the oil filter. The oil is drained through the drain hose. After draining the oil, tighten the drain plug.
4. Remove the spin-on type element from the filter head with a filter wrench.

#### IMPORTANT:

- Take care not to allow foreign matter such as dirt to enter the oil filter.
- Be careful not to damage the oil filter when removing or installing the filter.
- Never reuse the oil filter.

5. Fill the oil filter with clean engine oil.
6. After coating new oil filter gasket with engine oil, tighten the oil filter until the gasket comes in contact with the sealing surface. Take care that if the oil filter is overly tightened, the oil filter may become deformed.

**NOTE:** Install the oil filter with care so that the gasket is not damaged due to twisting. Check for any oil leakage at the filter mounting area.

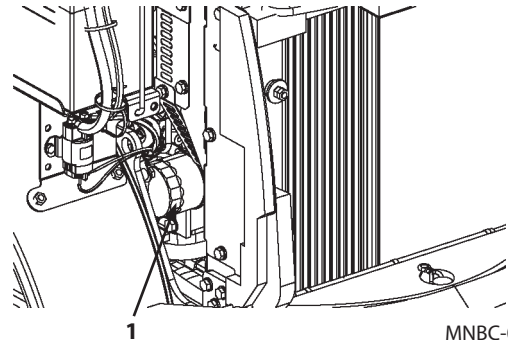

MNBC-07-005

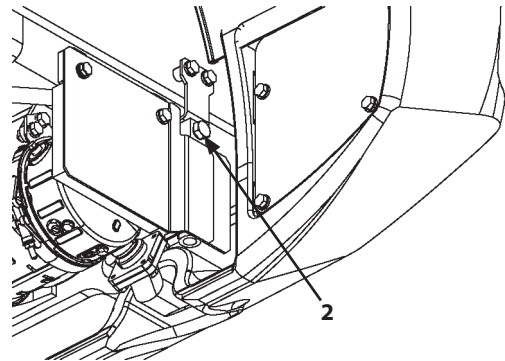

MNBC-07-004

## MAINTENANCE

### 4 Oil Separator Element (Blow-by Gases)

--- every 1000 hours or 1 year

**⚠ WARNING: Engine oil may be hot just after operation. Wait for oil to cool before starting work. Failure to do so may result in a burn.**

1. Park the machine according to Preparations for Inspection and Maintenance (7-5).
2. Clean the area around where oil separator (1) is mounted.
3. Remove separator case (2).
4. When separator case (2) is removed, element (3) is exposed. Remove it by hand. When doing so, make sure there are no problems like cracks in separator case (2) or inside the body of oil separator (4).
5. Replace the element with a new one and install separator case (2).

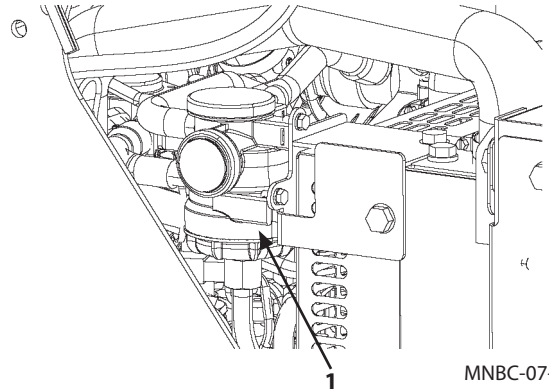

MNBC-07-021

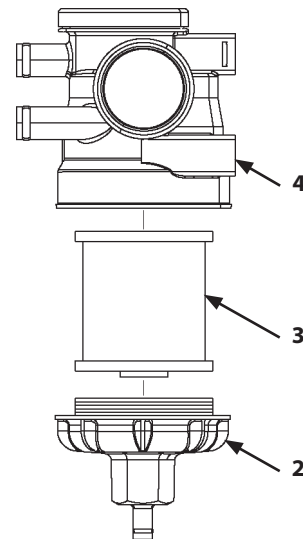

MNBC-07-022

## MAINTENANCE

### C. Power Train

- 1** Change Transmission Oil  
--- every 1000 hours or 1 year (Only first time at 250 hours or 3 months)

**⚠ WARNING:** Unexpected movement of the machine may cause serious accident. When parking the machine, place Forward/Reverse lever (1) in neutral and neutral lever lock (2) in the lock position. Then, apply parking brake (3) and stop the engine.

**⚠ WARNING:** Pay attention to the following points.

- Immediately after the machine has been operated, all engine parts will be hot. Wait for the engine to cool before starting any maintenance work. Failure to do so may cause severe burns.
- Secure the front and rear frames with articulation lock bar (4).

**IMPORTANT:** Do not use transmission oils other than those listed in the table for "Kind of oils".

1. Park the machine following the same procedures as described on page 7-5 for preparation of inspection/maintenance work.
2. Install articulation lock bar (4) to the front and rear of the frames by following the procedures described on page 7-6.
3. Turn the key switch OFF to stop the engine. Leave the machine untouched for 10 minutes.
4. Clean the area around drain plug (5) and oil level plug (7).
5. Prepare a container of approximately 2 liter capacity to receive the drain oil.
6. Remove drain plug (5) from the transmission bottom to drain the oil. Dispose of the drain oil in the proper way.
7. Securely tighten drain plug (5).
8. Refill the specified amount (1.5 liters) of oil through transmission oil filler port (6).
9. Check that the oil level is at the position of oil level plug (7) hole. Refill oil as necessary.
10. Install plug and check plugs for tightness.

**🔧 NOTE:** Finally, check for any oil leakage around drain plug.

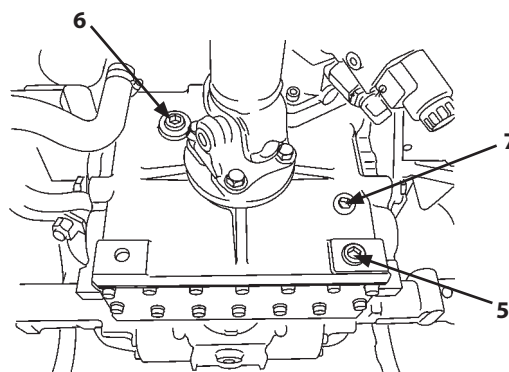
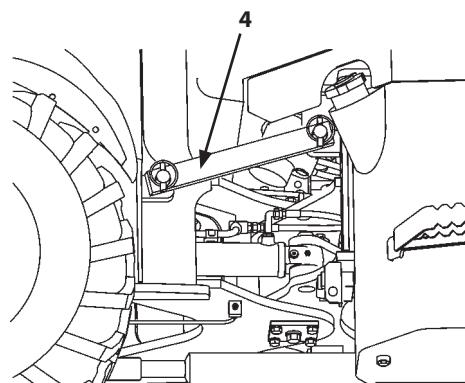
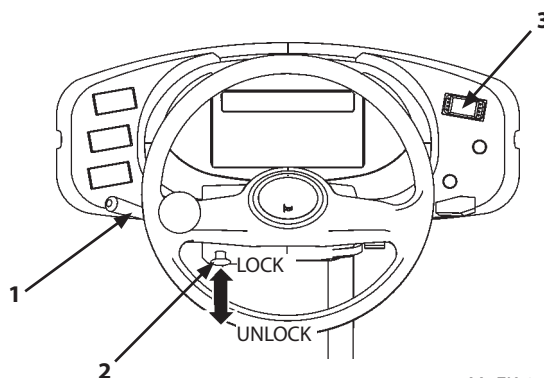



## MAINTENANCE

- 2** **Change Axle Oil**  
 --- every 1000 hours or 1 year (only first time at 250 hours or 3 months)

**⚠ WARNING:** Pay attention to the following points.

- Immediately after the machine has been operated, all engine parts will be hot. Wait for the engine to cool before starting any maintenance work. Failure to do so may cause severe burns.
- Secure the front and rear frames with articulation lock bar (4).

**IMPORTANT:** Do not use axle oils other than those listed in the table for "Kind of Oils" - "Transmission Oil".

### Change Axle Oil

1. Park the machine following the same procedures as described on page 7-5 for preparation of inspection/maintenance work.
2. Install the articulation lock bar to the front and rear of the frame following the procedures described on page 7-6.
3. Clean the area around drain plug (1) and oil level plug (2).
4. Arrange a container of approximately 9 liter capacity to receive the drain oil.
5. Remove drain plug (1) from axle bottom to drain the oil.
6. After cleaning off oil and coating drain plug (1) with LOCTITE #572 or equivalent, securely retighten the drain plug.
7. Refill the specified amount of oil through oil level plug (2) hole.

Front Axle	Rear Axle
4.5 L	4.5 L

**🔧 NOTE:** When refilling oil into the rear axle, remove the left side tire. Then, while holding the rear axle in a horizontal position, supply oil. Refer to "J. Tire" group for removal and installation of tire.

**IMPORTANT:** It takes time for oil to fully lubricate the overall front axle. After installing the plug, allow the machine to drive for several minutes. Then, stop the engine and check the axle for any oil leaks.

8. Install plug and tighten.

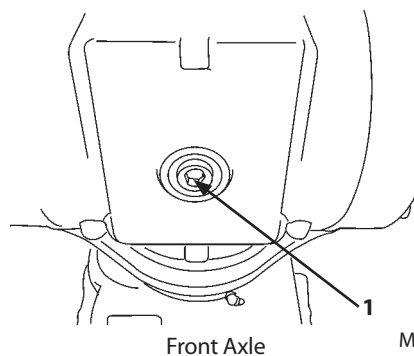

M4EJ-07C-002

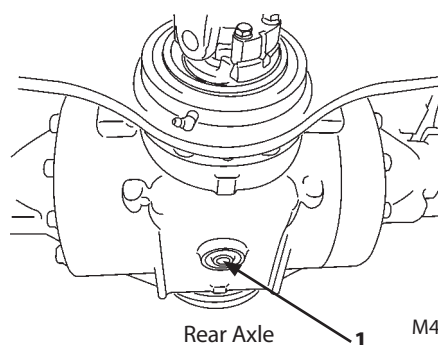

M4EJ-07C-003

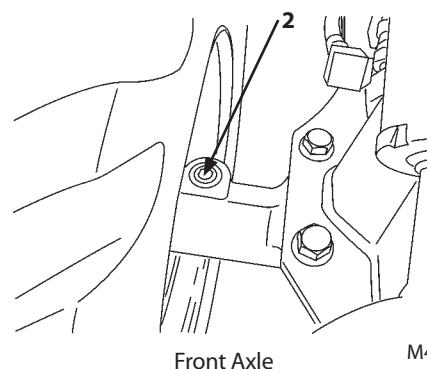

M4EJ-07C-004

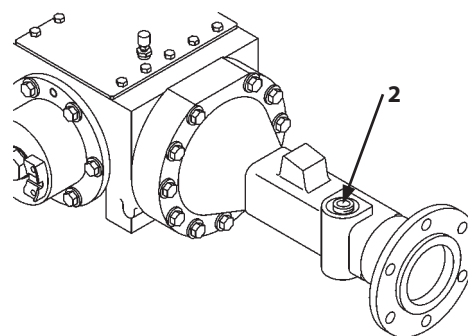

M4EJ-07C-005

## MAINTENANCE

### Check Oil Level

1. Park the machine following the same procedures as described on page 7-5 for preparation of inspection/maintenance work.
2. Install articulation lock bar (1) to the front and rear of the frame by following the procedures described on page 7-6.
3. Clean the area around oil level plugs (2).
4. Remove oil level plug (2). Clean the tip of dipstick (3) connected to oil level plug (2) with a clean cloth.

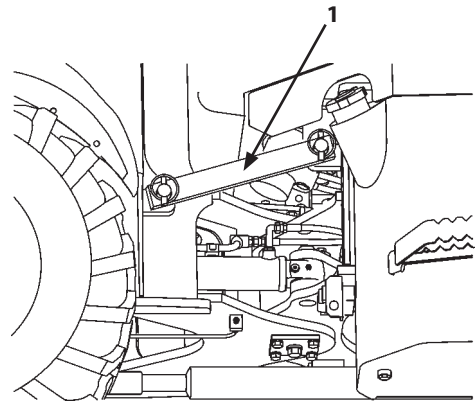

M4EK-01-053

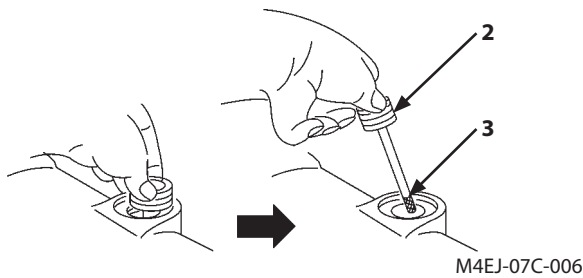

M4EJ-07C-006

5. Make the plug bottom contact to the axle seat face. When the oil level is correct, oil must adhere to the graded lines on the dipstick. Add oil as necessary.

 **NOTE:** When checking the oil level in the rear axle, remove the left side tire. Then, while holding the rear axle in a horizontal position, check the oil level. Refer to "J. Tire" group for removal and installation of tire.

6. Install plug and tighten.

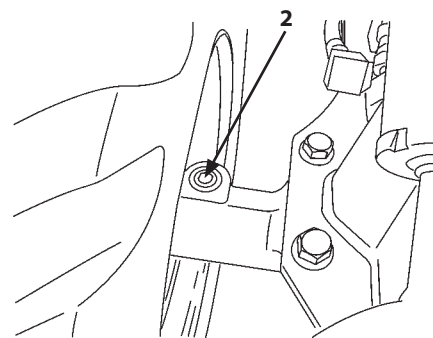

Front Axle

M4EJ-07C-004

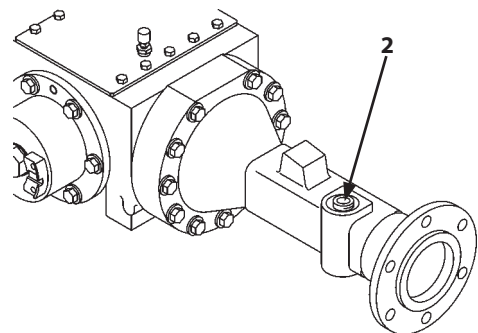

Rear Axle

M4EJ-07C-005

## MAINTENANCE

### 3 Clean Transmission Air Breather --- every 500 hours or 6 months

Air breather (1) is located at the upside of the transmission HST motor mounting section.

1. Clean the vicinity around air breather (1) before removing the air breather.
2. Put a cover on the air breather port to prevent foreign matter from entering.

**⚠ WARNING: Be sure to wear safety glasses or goggles when cleaning the air breather with compressed air.**

3. Clean air breather (1) using compressed air. If completely contaminated, wash the air breather with a cleaning solvent and reinstall it.
4. Take care not to allow foreign matter to enter into the transmission when reinstalling the air breather.

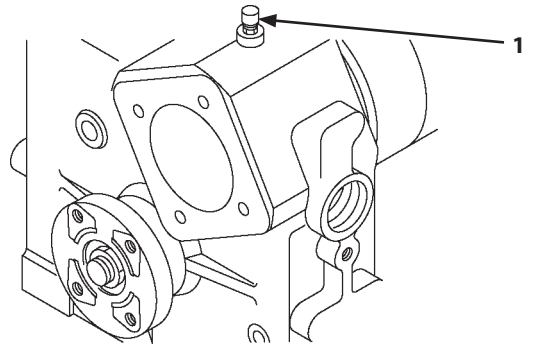

MNBD-07-002

## MAINTENANCE

### 4 Check Surrounding Areas Around Axles and Covers for Oil Leaks

--- every 1000 hours or 1 year

Check the surrounding areas around the axles and covers for oil leaks. If any oil leaks are found, check the bolts in the oil leaking area for tightness. Retighten as needed.

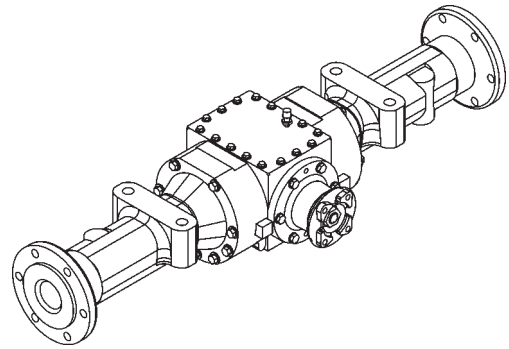

M4EJ-07C-008A

### 5 Clean Axle Housing Air Breather

--- every 500 hours or 6 months

1. Clean the vicinity of the air breather before removing the air breather.  
Open the machine front cover. Front axle air breather (1) is located at the right side. Rear axle air breather (2) is located at the left side of the base machine.
2. Put a cover on the air breather port to prevent foreign matter from entering.

**WARNING:** Be sure to wear safety glasses or goggles when cleaning the air breather with compressed air.

3. Clean the air breather using compressed air. If completely contaminated, wash the air breather with a cleaning solvent and reinstall it.
4. Take care not to allow foreign matter to enter into the axle housing when reinstalling the air breather.

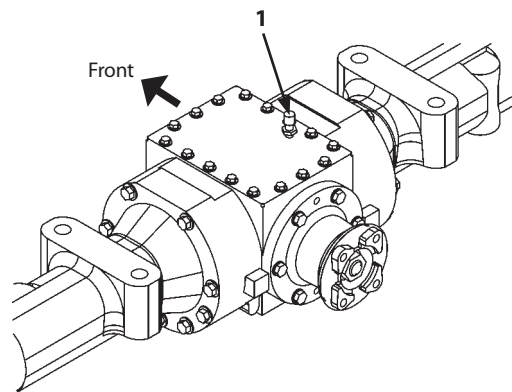

Front Axle Breather

M4EJ-07C-009A

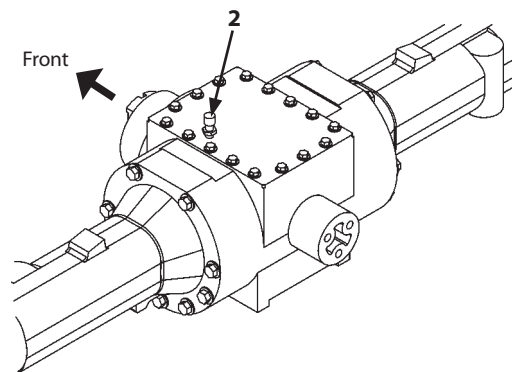

Rear Axle Breather

M4EJ-07C-010A

## MAINTENANCE

---

### D. Hydraulic System

#### Inspection and Maintenance of Hydraulic Equipment

**⚠ CAUTION:** During operation, the parts in the hydraulic system become very hot. Allow the machine to cool down before beginning inspection or maintenance.

1. Park the machine following the same procedures as described on page 7-5 for preparation of inspection/maintenance work.
2. Begin servicing hydraulic components only after components, hydraulic oil and lubricants have completely cooled, and only after releasing residual pressure.
  - 2.1. Operate all control levers several strokes to bleed off residual air pressure.
  - 2.2. Immediately after operation, all hydraulic components and hydraulic oil or lubricants are hot and highly pressurized. Begin inspection and/or maintenance work only after the machine has cooled down. Servicing heated and pressurized hydraulic components may cause plugs, screws and/or oil to fly off or escape suddenly, possibly resulting in personal injury. Keep body parts and face away from the front of plugs or screws when removing them. Hydraulic components may be pressurized even when cooled.

#### IMPORTANT:

- **When connecting hydraulic hoses and pipes, take special care to keep seal surfaces free from dirt and to avoid damaging them.**
- **Wash hoses, pipes and the tank interior including surrounding areas with washing liquid and thoroughly wipe it out before reconnecting.**
- **Only use O-rings that are free of damage or defects. Be careful not to damage them during reassembly. Do not allow high pressure hoses to twist when connecting them. The life of twisted hoses will be shortened considerably.**
- **Do not use hydraulic oils other than those listed in the table for "Kind of Oils" - "Hydraulic Oil".**
- **Never start the engine without first supplying hydraulic oil.**

## MAINTENANCE

### 1 Check Hydraulic Oil Level --- every 10 hours (daily)

**IMPORTANT:** If the oil level is not viewed in the level gauge, immediately refill hydraulic oil up to the appropriate level. Failure to do so may result in serious failure in the hydraulic system. If the oil level is higher than the level gauge, remove oil down to the appropriate level.

1. Park the machine following the same procedures as described on page 7-5 for preparation of inspection/maintenance work
2. Check oil level with level gauge (1) at the side of the hydraulic oil tank. Oil must be within the gauge.

 **NOTE:** During cold weather season, check the oil level after warming up the hydraulic oil by referring to the instructions described in the "Warm up operation" group.

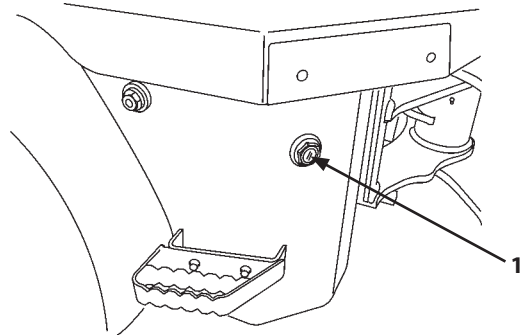

M4EK-07D-001

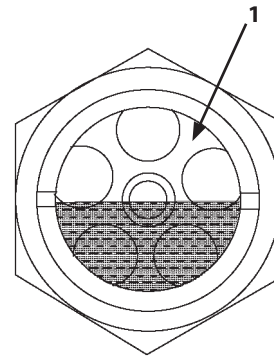

M4EJ-07D-002

## MAINTENANCE

### 2 Change Hydraulic Oil/Clean Hydraulic Oil Tank --- every 1000 hours or 1 year

#### Change/Cleaning

**⚠ WARNING:** Hydraulic oil becomes hot and pressurized during operation. Severe burns may result if skin comes in contact with escaping hydraulic oil immediately after operation. Wait for the oil to cool before starting any maintenance work.

**IMPORTANT:** Do not use hydraulic oils other than listed in the "Kind of Oils" - "Hydraulic Oil".

1. Park the machine following the same procedures as described on page 7-5 for preparation of inspection/maintenance work.
2. Install articulation lock bar (1) to the front and rear of the frames by following the procedures described on page 7-6.
3. Before changing hydraulic oil, be sure to relieve the air pressure from the hydraulic oil tank by slowly loosening oil filler port plug (2).

**IMPORTANT:** When changing hydraulic oil, take care not to allow foreign matter such as dirt, water or soil to enter the hydraulic oil tank.

4. Clean the vicinity of drain plug (4) on the bottom of hydraulic oil tank (3).
5. Arrange container of approx 40 liters to receive the drain oil.
6. Remove drain plug (4) to drain hydraulic oil.
7. Remove cleaning over (5) on the bottom of hydraulic oil tank (3). Clean the tank bottom with cleaning oil. Install the cover to the original position after leaning.
8. Securely tighten drain plug (4).

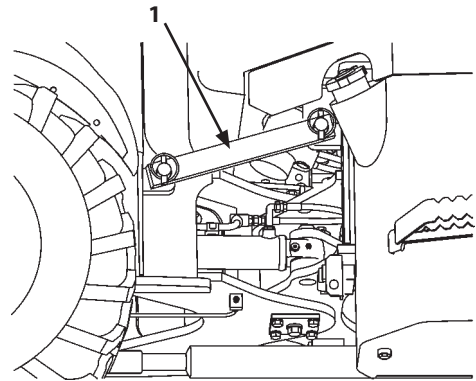

M4EK-01-053

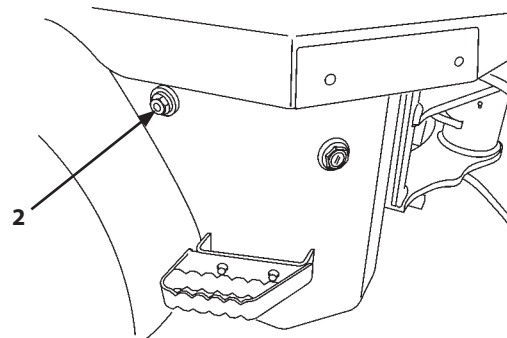

M4EK-07D-001

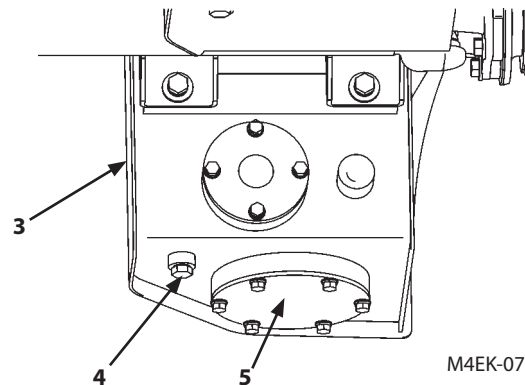

M4EK-07D-002A

## MAINTENANCE

- Remove oil filler port plug (2). Refill hydraulic oil while checking oil level with level gauge (6).  
Specified Oil Amount:

Hydraulic Oil Tank	Hydraulic System
33 L	38 L

- Install oil filler port plug (2).
- Start the engine. Slowly raise or lower the arm and tilt the bucket forward and backward. Stop the engine. Check for oil leaks. Check the oil level using level gauge (6).

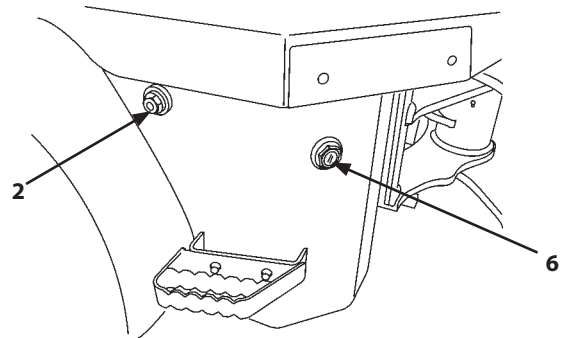

M4EK-07D-001

### Bleed Air from the Hydraulic System

After changing hydraulic oil or replacing the return filter, HST oil filter and/or suction filter, bleed air from the hydraulic system following the procedures below.

#### Procedures

- After supplying oil, start the engine. Move the bucket and lift arm cylinders several times to bleed air mixed in the hydraulic circuit.
- Rest the bucket on the ground to resume the hydraulic oil level check position.
- Stop the engine. Check the oil level. Add oil as needed.

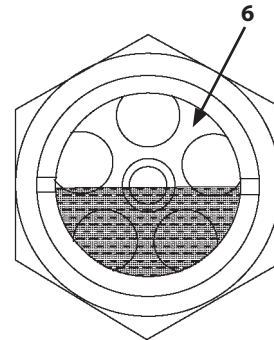

M4EJ-07D-002



## MAINTENANCE

### 3 Clean Suction Filter --- each time when hydraulic oil is changed

A suction filter is located on the bottom of the hydraulic oil tank. Clean the suction filter when changing hydraulic oil.

1. After draining hydraulic oil, remove suction hose (2) from the inside of hydraulic oil tank (1). Slowly remove suction filter (3) from hydraulic oil tank (1). Trapped debris will come from this filter.
2. Clean suction filter screen (3) with cleaning oil.
3. Remove cleaning cover (6) from the bottom of hydraulic oil tank (1). Clean the tank bottom with cleaning oil. Swab out cleaning oil with a lint free cloth. Install cleaning cover (6) in its original position after cleaning.
4. Check O-ring (4) for any kink or damage. Install suction filter (3) into hydraulic oil tank (1) with bolts (5) (4 used).
5. Connect hose (2) to suction filter (3) with hose clamps.
6. Refill hydraulic oil by the specified volume through the oil filler port while checking the oil level with oil gauge (7)
7. Start the engine. Slowly raise and lower the arm and tilt the bucket forward and backward to confirm that no abnormality is present. Stop the engine. Recheck the oil level with oil gauge (7).

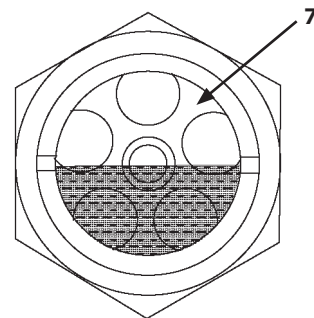
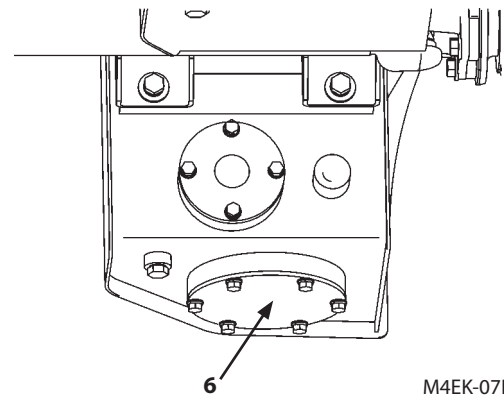
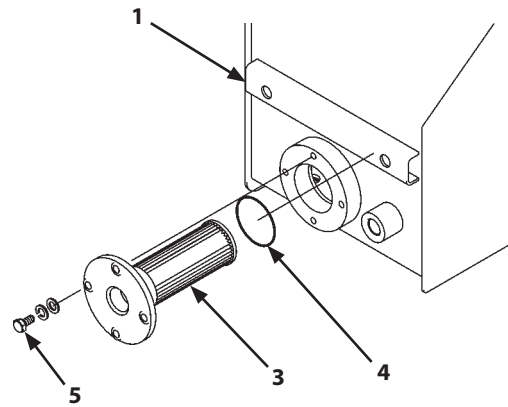
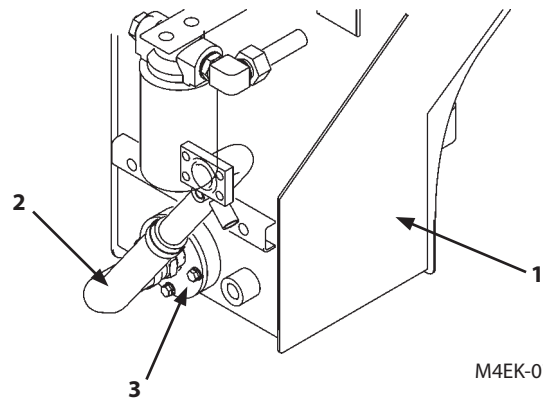

## MAINTENANCE

- 4** Replace HST Oil Filter Element  
--- every 1000 hours or 1 year (Only first time at 100 hours or 1 month)

**⚠ WARNING:** Hydraulic oil becomes hot and pressurized during operation. Severe burns may result if skin comes in contact with escaping hydraulic oil immediately after operation. Wait for the oil to cool, stop the engine, apply the parking brake and chock the tires before starting maintenance work.

The HST oil filter is located at the front-right side of the HST pump. Replace the element when changing hydraulic oil.

1. Park the machine following the same procedures as described on page 7-5 for preparation of inspection/maintenance work.
2. Install the articulation lock bar to the front and rear of the frames following the procedures described on page 7-6.
3. Before removing the filter, arrange a container and workshop towel to catch the drain oil and the element.
4. Slowly loosen oil filler port plug (1) to relieve the air pressure from the hydraulic oil tank.
5. Rotate the hexagonal section on the bottom of filter (2) counterclockwise with a wrench to remove the filter from filter head (3).

### IMPORTANT:

- Do not allow foreign matter such as dirt to enter filter (2).
- When installing or removing spin on filter (2), be careful not to damage it.
- Do not reuse the element.

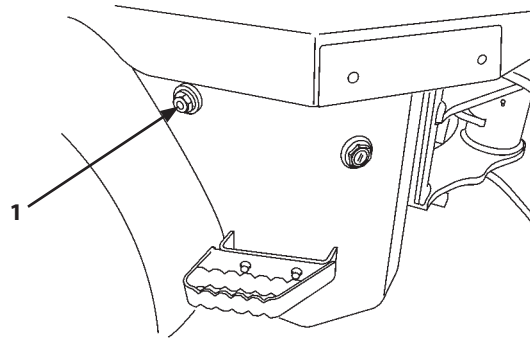

M4EK-07D-001

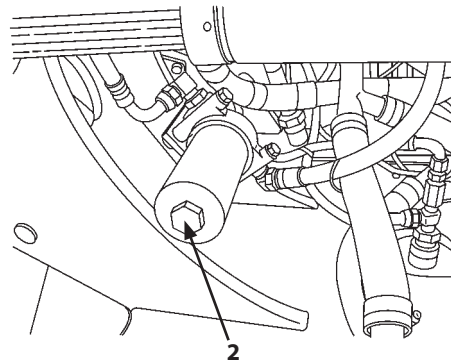

M4EJ-07D-005

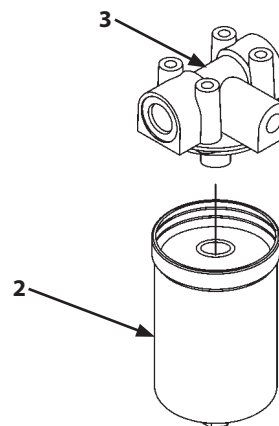

M4EJ-07D-006

## MAINTENANCE

---

6. Pour new hydraulic oil into filter (2)
7. Coat gasket (4) on new filter (2) with hydraulic oil. Install filter (2) to filter head (3) by turning the hexagonal section on the bottom of filter (2) with a wrench. After gasket (4) comes in contact with the seal surface on filter head (3), further tighten the element 3/4 turns.

 **NOTE:** When installing the filter, take care not to allow gasket (4) to break due to twisting. Check for oil leaks around the mounting surface of filter (2).

8. After replacing the filter element, bleed air from the hydraulic system and check the oil level in the hydraulic oil tank. Refer to the descriptions for "Bleed air from the hydraulic system". If the machine is operated without bleeding air from the hydraulic circuit, damage to the hydraulic pump may result.

 **NOTE:** Replace the filter at the regular intervals to keep hydraulic oil clean and extend the service life of hydraulic components.

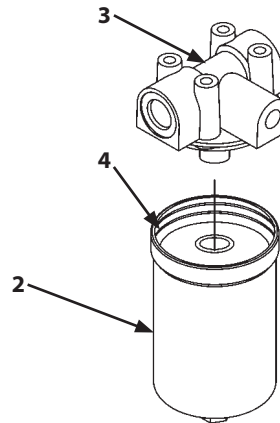

M4EJ-07D-006

## MAINTENANCE

- 5** **Replace Return Filter**  
--- every 1000 hours or 1 year (Only first time at 100 hours or 1 month)

**⚠ WARNING:** Hydraulic oil becomes hot and pressurized during operation. Severe burns may result if skin comes in contact with escaping hydraulic oil immediately after operation. Wait for oil to cool before starting any maintenance work.

Remove the maintenance access cover at the operator's seat floor. The return filter is located on the right side. Replace the filter when changing hydraulic oil.

1. Park the machine following the same procedures as described on page 7-5 for reparation of inspection/maintenance work.
2. Install the articulation lock bar to the front and rear of the frames following the procedures described on page 7-6.
3. Before removing the filter, arrange a container and workshop towel to catch the drain oil and the filter.
4. Slowly loosen oil filler port plug (1) to relieve the air pressure from the hydraulic oil tank.
5. Rotate the hexagonal section on the bottom of filter (2) counterclockwise with a wrench to remove the filter from filter head (3).

### IMPORTANT:

- Do not allow foreign matter such as dirt to enter filter (2).
- When installing or removing spin on filter (2), be careful not to damage it.
- Do not reuse the element.

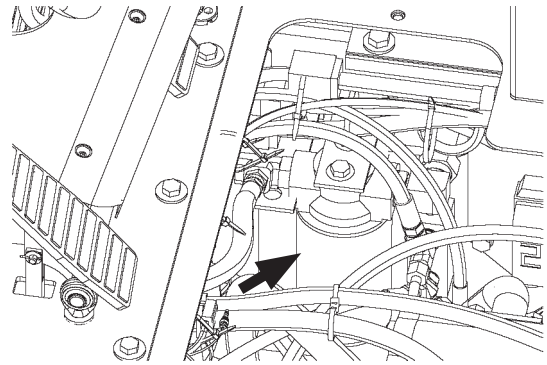

MNBC-07-017

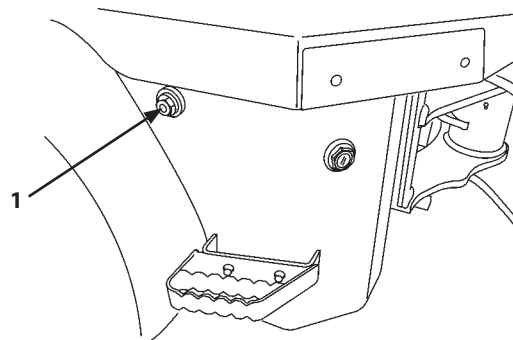

M4EK-07D-001

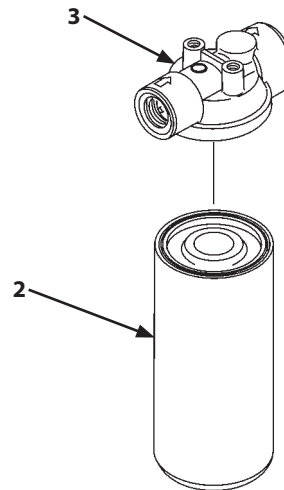

M4EJ-07D-008

## MAINTENANCE

---

6. Pour new hydraulic oil into filter (2).
7. Coat gasket (4) on new filter (2) with hydraulic oil. Install filter (2) to filter head (3) by turning the hexagonal section on the bottom of filter (2) with a wrench. After gasket (4) comes in contact with the seal surface on filter head (3), further tighten the element by 3/4 turns. Take care not to damage filter (2) as it may become deformed if overly tightened.

 **NOTE:** When installing the filter, take care not to allow gasket (4) to break due to twisting. Check for oil leaks around the mounting surface of filter (2).

8. After replacing the filter element, bleed air from the hydraulic system and check the oil level in the hydraulic oil tank. Refer to the description for "Bleed air from the hydraulic system". If the machine is operated without bleeding air from the hydraulic circuit, damage to the hydraulic pump may result.

 **NOTE:** Replace the filter at the regular intervals to keep the hydraulic oil clean and extends the service life of hydraulic component.

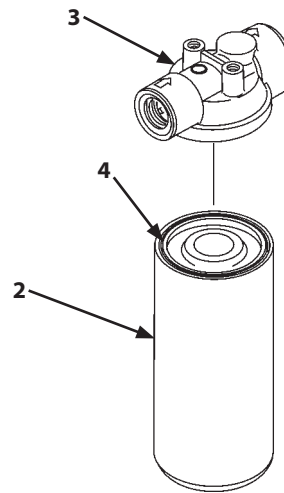

M4EJ-07D-008

## MAINTENANCE

**6** Check Hoses and Lines  
 --- every 10 hours (daily)/every 250 hours or 3 months

**⚠ WARNING:** Escaping combustible fluid can cause fires. Check for missing or loose clamps, kinked hoses, lines or hoses that rub against each other, and oil leaks. Escaping oil under pressure can penetrate the skin causing serious injury. To avoid this hazard, search for oil leaks with a piece of cardboard. Take care to protect hands and body from high-pressure fluids. If an accident occurs, see a doctor familiar with this type of injury immediately. Tighten, repair or replace any missing, loose or damaged clamps, hoses, or lines. Do not bend or strike high-pressure lines. Never reinstall bent or damaged hoses or lines.

According to the check points shown below, check hoses and lines for oil leaks and damage. If any trouble is found, replace or retighten as instructed in the table.



SA-031



SA-292

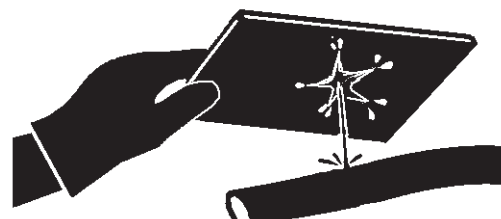

SA-044

Hoses

Interval (hours)	Check Points	Abnormalities	Remedies
Every 10 hours	Hose covers Hose ends Fittings	Leak (1) Leak (2) Leak (3)	Replace Replace Retighten or replace hose or O-ring

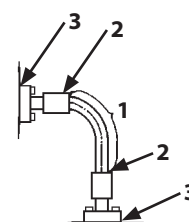

M4GB-07-053

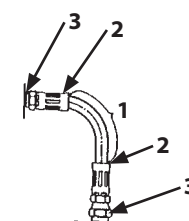

M4GB-07-054

## MAINTENANCE

Interval (hours)	Check Points	Abnormalities	Remedies
Every 250 hours	Hose covers	Crack (4)	Replace
	Hose ends	Crack (5)	Replace
	Hose covers	Exposed reinforcement (6)	Replace
	Hose ends	Blister (7)	Replace
	Hose	Bend (8), Collapse (9)	Replace
	Hose ends and Fittings	Deformation or corrosion (10)	Replace

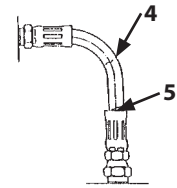

M4GB-07-055

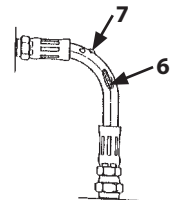

M4GB-07-056

### Lines

Interval (hours)	Check Points	Abnormalities	Remedies
Daily	Contact surfaces of flange joints	Leak (11)	Replace
	Bolts	Loose or leak (11)	Retighten or replace O-ring
	Welded surfaces on flange joints	Leak (12)	Replace
Every 250 hours	Flange joint neck	Crack (13)	Replace
	Welded surfaces on flange joints	Crack (12)	Replace
	Clamps	Missing or deformation	Replace or retighten
		Loose bolts	

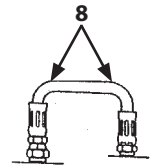

M4GB-07-057

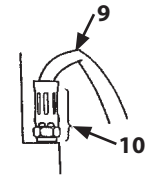

M4GB-07-058

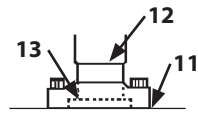

M4GB-07-059

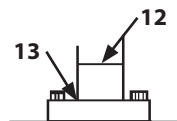

M4GB-07-060

## MAINTENANCE

### Service Recommendations for Hydraulic Fittings

#### Kinds of Hose/Line fittings

Two hydraulic fitting designs are used on this machine.

#### Flat Face O-ring Seal Fittings

An O-ring is used on the sealing surface to prevent oil leakage.

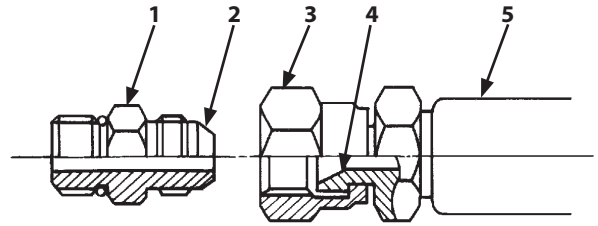

M4GB-07-062

#### 1. Metal Face Seal Fittings

Tight contact between metal flares on adaptor (1) and connector (3) of hose (5) prevents pressure oil leakage. This type of fitting is used on smaller diameter joint.

### Precautions for Use

Connect or disconnect fittings with care so as not to damage seat surfaces (2 and 4).

#### Tightening Torque

Tighten fittings to the torque values shown below

Wrench size (mm)		19	22	27
Tightening torque	N·m	29	39	93
	(kgf·m)	(3.0)	(4.0)	(9.5)



## MAINTENANCE

### E. Fuel System

- 1 **Check Fuel Level**  
--- every 10 hours (daily)

**⚠ WARNING:** Beware of fire. Fuel is flammable. Keep fuel away from fire hazards.

#### Recommended Fuel

Use only super high quality or high quality DIESEL FUEL (JIS K-2204) (ASTM D-975).

Besides, using bad quality fuel, drainage agent, fuel additives, gasoline, kerosene or alcohol refueled or mixed with specified fuel may deteriorate performance of fuel filters and cause sliding problem at lubricated contacts in the injector.

Using fuel other than ultra low-sulfur or low-sulfur diesel fuel has adverse effects on the engine and the muffler, which may result in malfunction.

**IMPORTANT:** Always fill the fuel tank with the specified diesel fuel. Failure to do so may cause engine trouble and may also make the engine difficult to start. Do not use fuel additives as these can damage the fuel system.

#### Refueling

1. Park the machine following the same procedures described on page 7-5 for preparation of inspection/maintenance work.
2. Check the fuel level with gauge (1). Remove cap (2) on the fuel tank to add fuel as necessary.
3. Fill the tank at the end of each day's operation.  
Fuel tank capacity: 45 liters  
Add fuel, and be sure that fuel tank is not overfilled.
4. Immediately after fueling, install and lock fill cap (2) to prevent vandalism and loss.

**✎ NOTE:** When fueling, do not remove strainer (3) from the filler port. Take care not to allow dirt and/or water to enter the fuel tank.

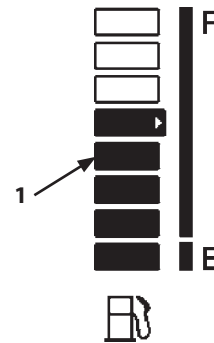

MNBC-01-028

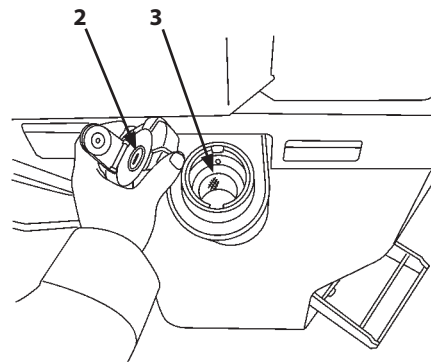

M4EJ-07E-001

## MAINTENANCE

---

### **2** Drain Water and Sediment from Fuel Tank

--- every 1000 hours or 1 year

Before starting to operate the machine, loosen drain plug (1) on the fuel tank bottom to drain water and/or sediment from the fuel tank.

Tighten plug when no more water is draining, and only fuel drainage is seen.

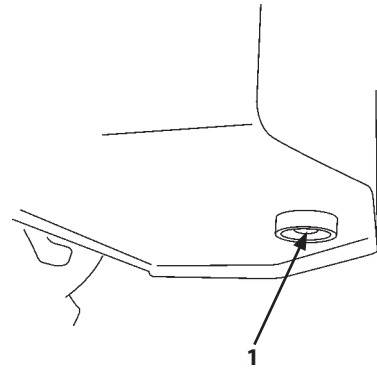

M4EK-07E-001

## MAINTENANCE

### 3 Drain Water Separator --- every 10 hours (check daily)

**IMPORTANT:** Drain water separator daily before starting operation. The engine may be damaged if you do not drain it daily.

The water separator acts to separate water from the fuel and functions via a float which rises when water accumulates. Check the float position daily and drain the accumulated water until the float goes to the bottom of the case.

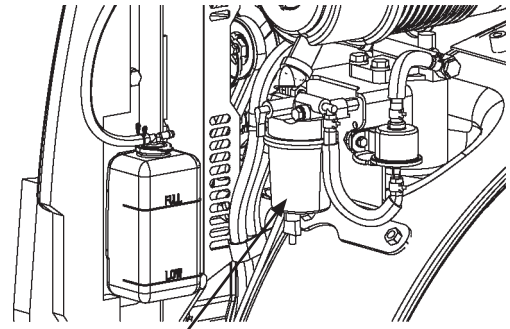

Water Separator

MNBC-07-007

#### Drain Procedure

1. Park the machine according to Preparations for Inspection and Maintenance (7-5).
2. Close fuel cock (1).
3. Place a 0.3 liter or larger container under drain plug (2).
4. Rotate drain plug (2) counterclockwise and drain the water inside until float (4) goes to the bottom of the case.

If water fails to drain properly, loosen air bleed plug (3) on the top of the water separator.

5. After draining water, securely tighten drain plug (2) and air bleed plug (3).
6. Open fuel cock (1).
7. Bleed air from the fuel system.

After draining the water separator, bleed air from the fuel supply system.

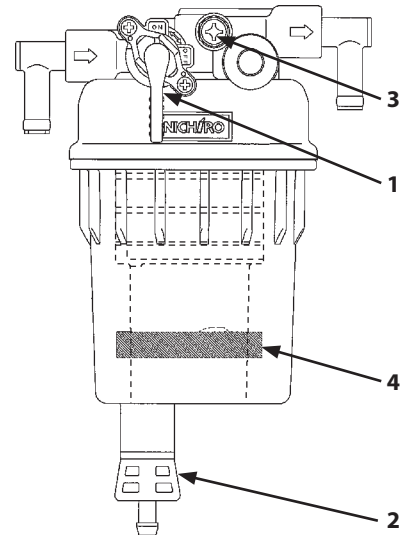

MNBC-07-018

## MAINTENANCE

---

### Bleed Air from the Fuel System

 **NOTE:** Air in the fuel system may cause the engine to become difficult to start or other engine trouble. In case the machine runs out of fuel in the fuel tank, after the fuel filter is drained, or the element is replaced, bleed air from the fuel system.

1. Turn key switch (1) to ON position (2). The electric fuel pump will operate and purge air.
2. Start the engine. Check the fuel system for fuel leaks.

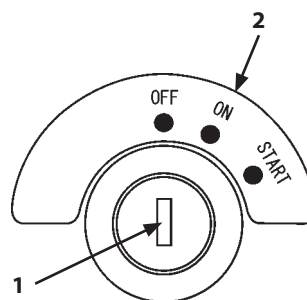

MNBC-01-013

## MAINTENANCE

### 4 Replace Main Fuel Filter Element --- Every 500 hours or 6 months

#### **CAUTION: Danger of Fire**

Fuel is dangerous as it can burn easily. Keep away from fire.

#### **IMPORTANT:**

- Only use genuine Hitachi elements for the main fuel filter element. Using a different element may adversely affect engine performance and/or shorten the engine service life. Note: any engine failure caused by using other manufacturers' elements is excluded from the Hitachi Warranty Policy.
- Take care to keep dirt and water out of the system during replacement.
- Contact a recovery specialist or your authorized dealer to dispose of old oil and filters.  
Never dump waste illegally as doing so destroys our global environment.

1. Park the machine according to Preparations for Inspection and Maintenance (7-5).
2. To provide space to work, loosen bolt (3) and lower fender (4) out of the way.
3. Close fuel cock (1).
4. Place a 1 liter or larger container under main fuel filter (2).
5. Remove main fuel filter (2) using a filter wrench.
6. Clean the mounting face of main fuel filter (2).
7. Apply a thin film of fuel to the gasket face of the new main fuel filter (2).
8. Turn main fuel filter (2) clockwise by hand until it touches the contact area.
9. Tighten a further half turn with the filter wrench.  
Tightening Torque: 20 to 24 N·m (2.0 to 2.4 kgf·m)
10. Open fuel cock (1).
11. Tighten bolt (3) again after returning fender (4) to its original position.
12. Bleed air from the fuel system.

After replacing the fuel filter element, bleed air from the fuel supply system.

(Refer to [3](#) "Bleed Air from the Hydraulic System".)

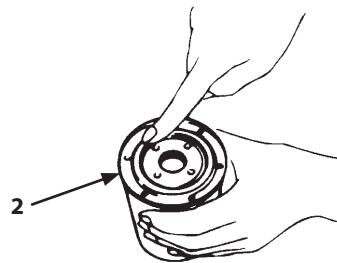
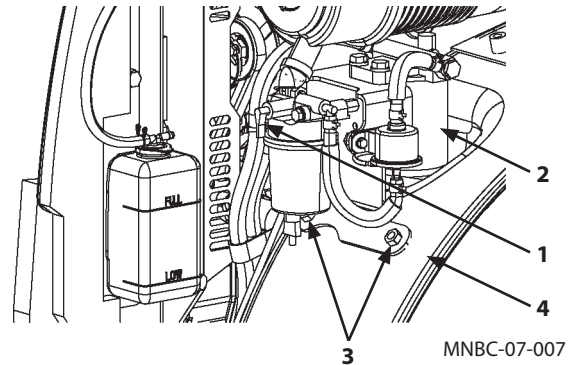

## MAINTENANCE

### 5 Clean the Water Separator --- every 500 hours or 6 months

#### **CAUTION: Danger of Fire**

Fuel is dangerous as it can burn easily. Keep away from fire.

**IMPORTANT: Contact a recovery specialist or your authorized dealer to dispose of old oil and filters.**

**Never dump waste illegally as doing so destroys our global environment.**

1. Park the machine according to Preparations for Inspection and Maintenance (7-5).
2. Close fuel cock (1).
3. Loosen air bleed plug (3) and drain plug (2). Drain fuel until no fuel flows out of the water separator.

To ensure safety and to avoid contaminating the ground, use a container to catch the fuel.

4. Use a filter wrench to remove filter cap (5) from filter head (4).
5. Wash out the inside of filter cap (5) with kerosene.
6. Clean element (7) with kerosene and blow out debris from the inside with compressed air at no higher than 0.2 MPa (2 kgf/cm<sup>2</sup>).
7. Inspect the O-ring and replace with a new one if damaged.
8. Reinstall in the reverse order. Assemble element (7) and float (6) inside filter cap (5).
9. Open fuel cock (1).
10. Bleed air from the fuel system.

After cleaning the water separator, bleed air from the fuel supply system.

(Refer to **3** "Bleed Air from the Hydraulic System".)

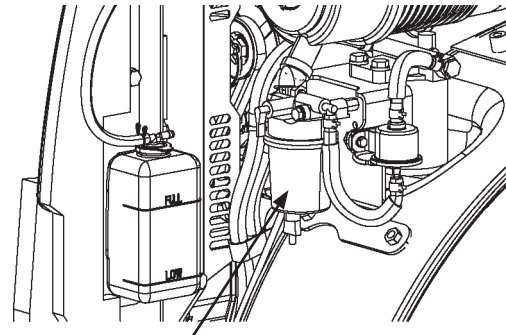

Water Separator

MNBC-07-007

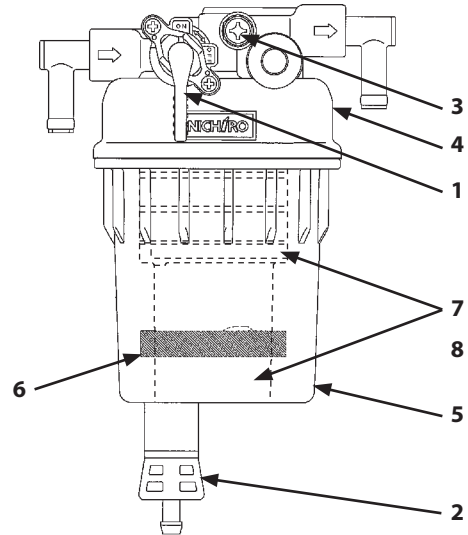

MNBC-07-018

## MAINTENANCE

**6** Check Fuel Hoses  
--- every 10 hours (daily)/250 hours or 3 months

**⚠ CAUTION:** Fuel leaks can lead to fires that may result in serious injury.  
Escaping combustible fluid can cause fires. Check for kinked hoses, hoses that rub against each other, and fuel leaks.  
**Repair or replace loose or damaged hoses. Never reinstall bent or damaged hoses.**

According to the check points shown below, check hoses and lines for oil leaks and damage. If any trouble is found, replace or retighten as instructed in the table.

Hoses

Interval (hours)	Check Points	Abnormalities	Remedies
Every 10 hours	Hose end	Leak (1)	Retighten or replace
Every 250 hours	Hose end	Crack (4)	Replace
	Hose	Bend (5), Collapse (6)	Replace
	Hose fittings	Corrosion (7)	Replace

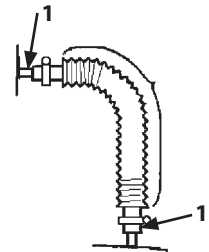

M4GB-07-071

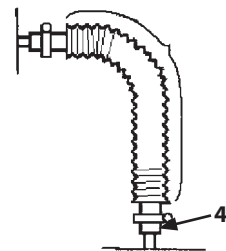

M4GB-07-072

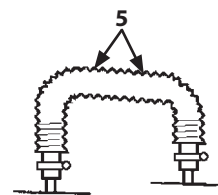

M4GB-07-073

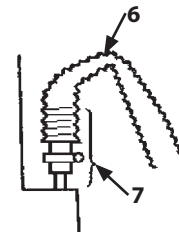

M4GB-07-074

## MAINTENANCE

### F. Air Cleaner

#### 1 Clean and Replace Air Cleaner Element

**Cleaning** --- When the visual inspection type dust indicator becomes red.

**Replacement** --- After cleaning 6 times (or every 1 year)

**CAUTION:** Wear goggles or safety glasses when using compressed air [less than 0.2 MPa (2 kgf/cm<sup>2</sup>)].

**IMPORTANT:** To clean element (2) (3), avoid bumping or striking element with other objects.

Air cleaner (1) is comprised of double elements, outer element (2) and inner element (3). Clean only outer element (2). In case severely contaminated, remove inner element (3) and clean it in the same cleaning method as the outer element. When outer element (2) has been replaced 6 times or when damaged, replace inner element (3).

1. Park the machine following the same procedures described on page 7-5 for preparation of inspection/maintenance work.
2. Loosen clip band (5) and remove dust cap (4). Clean out dust from inside the cap.
3. Remove outer element (2). Clean outer element (2) by blowing compressed air [less than 0.2 MPa (2 kgf/cm<sup>2</sup>)] from the inner side of the filter element outward. After cleaning is complete, be sure to check outer element (2) for any damage. If any damage is found, replace the element with a new one.
4. In case the air cleaner restriction indicator lights soon after cleaning outer element (2) even if the cleaning intervals are less than 6 times, replace both outer and inner elements with new ones.
5. Install dust cap (4) in the original position so that arrow marks (6) (↑TOP↑) point upward.
6. After cleaning, run the engine at low-speed and make sure clogging is not detected.

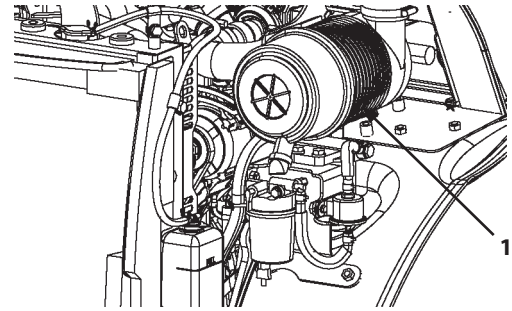

MNBC-07-008

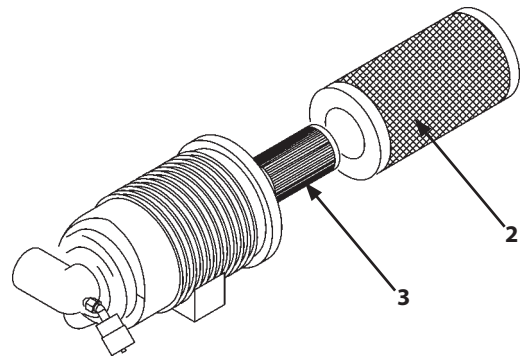

M4EK-07F-004

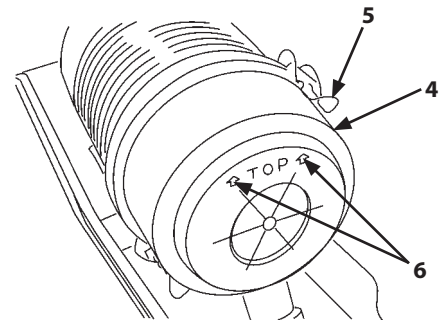

M4EJ-07F-003



## MAINTENANCE

---

### G. Cooling System

**IMPORTANT:** Use only long life coolant (LLC) described in the "Brand Names of recommended LLC". Use fresh water or normal tap water. Do not use river-water, well-water or fountain-water which would have an adverse effect to the engine and radiator so that the cylinder liner would become corroded.

 **NOTE:** The machine shipped from the factory is filled with coolant mixed with LLC. In this case, the coolant is usable through the year. Change the coolant at the earliest specified interval.

#### Kinds of Antifreeze

Two types of antifreeze, normal antifreeze and long life coolant (LLC), are available.

- Use long life coolant (LLC). Long life coolant (LLC) is usable through the year. Change coolant only after cleaning the cooling system.

When adding long life coolant (LLC), supply the same brand and same mixture ratio of LLC as already used in the machine.

Cylinder Liner



M4GB-07-156

## MAINTENANCE

---

### Precautions for Handling Long Life Coolant (LLC)

 **WARNING:** Long life coolant (LLC) is poisonous.

- If ingested by mistake, induce vomiting and get emergency medical attention immediately.
- If antifreeze is accidentally splashed into eyes, freely flush with water and get emergency medical attention.
- When storing LLC, be sure to keep it in a clearly marked container with a tight lid. Always keep LLC out of the reach of children.
- Be careful of fire hazards. LLC is specified as a dangerous substance in the fire protection law.
- When disposing of LLC, be sure to comply with all local regulations.

 **NOTE:** The LLC mixture ratio filled for the machines shipped from the factory is 50 %. In case a machine destination is nominated as a cold weather district, the mixture ratio is increased to 50 %.

Air temperature	Mixture ratio (%)	Total capacity: 6.5 L	
		LLC	Soft water
-15 °C (5 °F) or higher	30	2.0 L	4.5 L
-20 °C (-4 °F) or higher	35	2.3 L	4.2 L
-25 °C (-13 °F) or higher	40	2.6 L	3.9 L
-35 °C (-31 °F) or higher	50	3.3 L	3.2 L

## MAINTENANCE

### 1 Check Coolant Level --- every 10 hours (daily)

**⚠ WARNING:** Do not remove cap (4) until the coolant temperature in the radiator has cooled. Hot steam and coolant may spout out, possibly causing severe burns. After the coolant temperature cools, slowly loosen cap (4) to release the inside air pressure before removing cap (4).

Check the coolant level at reservoir tank (1). The normal coolant level is between the FULL (2) and LOW (3) marks on the side surface of reservoir tank (1).

In case no coolant is present in reservoir tank (1), add the coolant mixture via the cap hole on reservoir tank (1).

- When refilling long life coolant (LLC), use the same brand product and the same mixture ratio as already used in the machine.
- If only water is refilled, the mixture ratio in the long life coolant (LLC) is diluted so that anti-rust and antifreeze effect in the coolant will deteriorate, and it will cause corrosion.

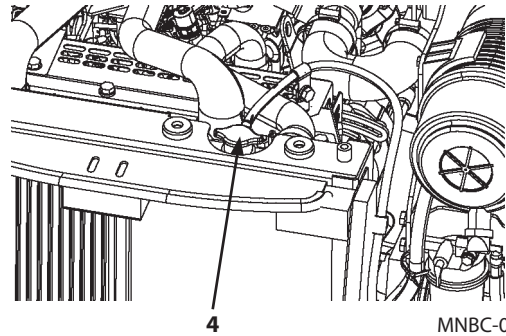

MNBC-07-009

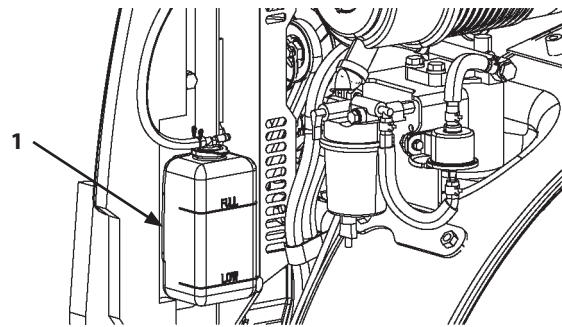

MNBC-07-007

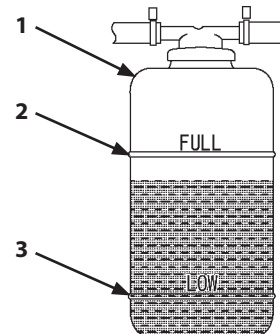

M4EJ-07G-007

## MAINTENANCE

### 2 Check Fan Belt --- every 10 hours (daily)

Check fan belt (1) for any troubles. If any cracks are found, replace the belt with a new one.

### 3 Check Fan Belt Tension --- every 250 hours or 3 months

**IMPORTANT:** Loose fan belt may result in insufficient battery charging, engine overheating, as well as premature belt wear. An excessively tight belt, however, can damage both water pump and alternator bearings and fan belts.

Check fan belt (1) tension by depressing the midpoint between crank pulley (3) and alternator pulley (2) with the thumb. Normal deflection must be 7 to 9 mm with a depression force of approximately 98 N (10 kgf).

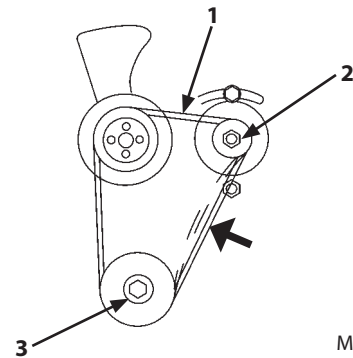

M4EJ-07G-003

### 4 Adjust Fan Belt Tension --- every 500 hours or 6 months (or whenever slack is found)

1. Loosen nut (5) and mounting bolt (6) of alternator (4).
2. Adjust belt tension by moving alternator (4) forward or backward.
3. Securely tighten bolt (6) and nut (5).

 **NOTE:** When a new belt is installed, be sure to readjust the belt tension after operating the machine for 3 to 5 minutes at slow idle speed to be sure that the new belt is correctly seated.

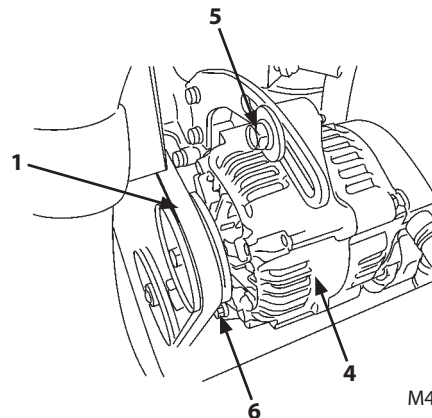

M4EJ-07G-004

## MAINTENANCE

### 5 Change Coolant --- every 1000 hours or 1 year

**CAUTION:** Do not remove the radiator cap until the coolant temperature in the radiator cools. Hot steam and coolant may spout out, possibly causing severe burns. After the coolant temperature cools, slowly loosen the cap to release the inside air pressure before removing the cap.

1. Park the machine following the same procedures described on page 7-5 for preparation of inspection/maintenance work.
2. Install the articulation lock bar to the front and rear of the frames following the procedures described on page 7-6.
3. Remove radiator cap (1). Open radiator drain plug (2) and engine water jacket drain plug (3) to completely drain the coolant. Remove impurities such as scale at the same time.
4. Close radiator drain plug (2) and engine water jacket drain plug (3). Supply low impurity soft water or tap water together with the specified LLC up to the radiator filler port. Slowly add coolant to avoid air from becoming mixed in the system. Start the engine and sufficiently bleed air from the cooling system.
5. After adding coolant, operate the engine for several minutes. Check the coolant level again and add coolant as necessary.

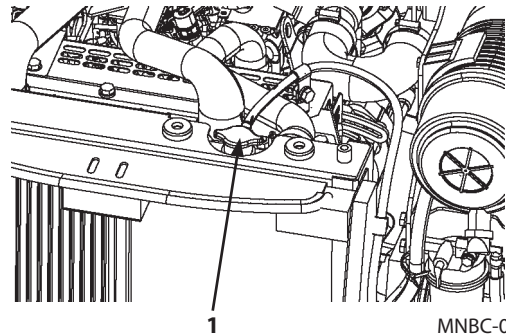

MNBC-07-009

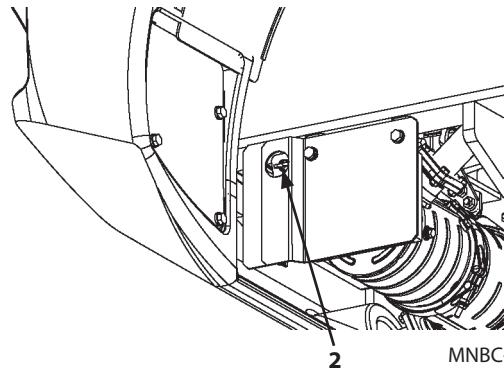

MNBC-07-010

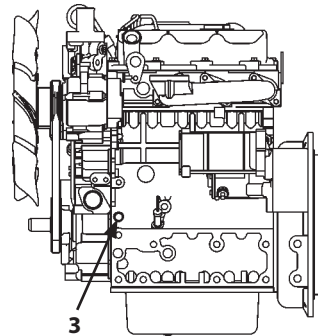

M4EN-07G-003

## MAINTENANCE

- 6** Clean Radiator, Oil Cooler and Inter Cooler Core  
--- every 100 hours, 1 month or when clogged

**⚠ WARNING:** Wear safety glasses or goggles when using compressed air [less than 0.2 MPa (2 kgf/cm<sup>2</sup>)].

**IMPORTANT:** If air at a pressure higher than 0.2 MPa (2 kgf/cm<sup>2</sup>) or tap water under high pressure is used for cleaning, damage to the radiator/oil cooler/inter cooler fins may result.

Keep the nozzle at least 500 mm away from the core surface.

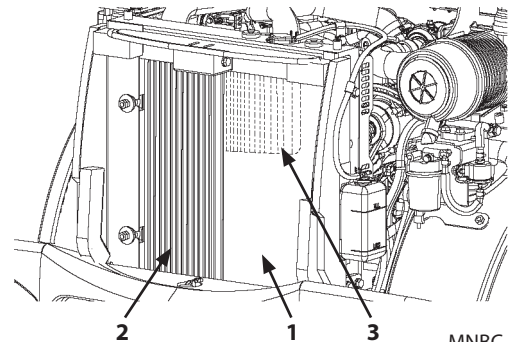

MNBC-07-011

If dust or dirt are on them, clean the radiator (1), oil cooler (2) and/or intercooler (3) cores with compressed air (0.2 MPa (2 kgf/cm<sup>2</sup>) or lower) or tap water. This prevents a drop in performance of the cooling system.

They can be cleaned from the engine side if cover (4) is removed.

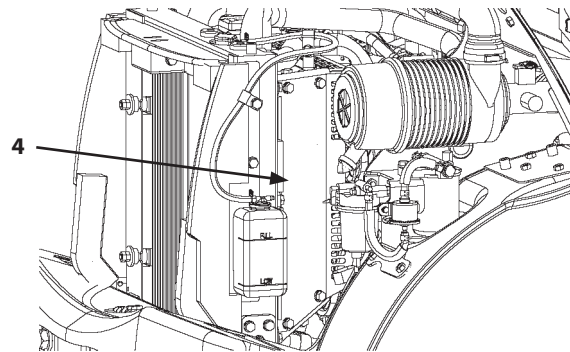

MNBC-07-019

## MAINTENANCE

### H. Electrical System

#### 1 Check Monitor Function and All Other Instrument Operation

--- every 10 hours (daily)

Run the engine at slow idle speed when checking the instruments. The monitor indicates alarm, caution and confirmation status in red, orange, and normal operative condition in blue or green respectively. Check the needle movement of each gauge and meter with the key switch ON. The needle shall be moved to the blue range when normal and to the red range when abnormal. Refer to the Group of Operator's Station in Section 1 for more information.

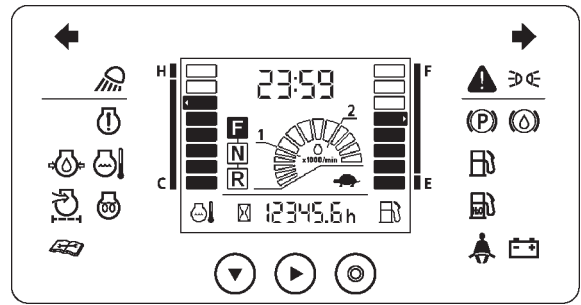

MNBC-01-024

#### IMPORTANT:

- **Improper radio communication equipment and associated parts, and/or improper installation of radio communication equipment may effect the machine's electronic parts, causing involuntary movement of the machine. Also, improper installation of electrical equipment may cause unexpected machine failure and/or fire on the machine.**  
**Be sure to consult your nearest authorized dealer when installing radio communication equipment or additional electrical parts.**
- **Never attempt to disassemble or modify the electrical/electronic components. If replacement or modification of such components is required, contact your nearest authorized dealer.**

## MAINTENANCE

### 2 Check Work Lights --- every 10 hours (daily)

**CAUTION:** If any burned-out lights are found, immediately replace it with a new one.

Visually check that all work lights normally light and/or blink from the front and rear sides of the machine.

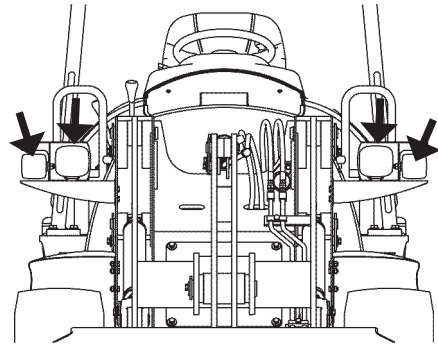

ME804-01-017

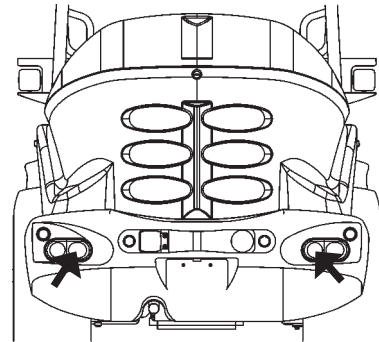

M4EK-01-014

### 3 Check Horn, Backup Alarm and Backup Light --- every 10 hours (daily)

**WARNING:** Before checking the horn and/or the backup buzzer, always apply the parking brake and clear all personnel from the machine's vicinity.

The horn switch button is located at the steering wheel center. Horn (1) is located at the right side of the front work light bracket. Backup alarm (3) is located at the left side of the center counterweight. Check that backup alarm (3) correctly sounds by operating the forward/reverse selector lever to the reverse drive side (R). Backup light (2) is located at the left side of the center counterweight. Check that backup light (3) turns ON when the forward/reverse selector lever is moved to the reverse drive side (R).

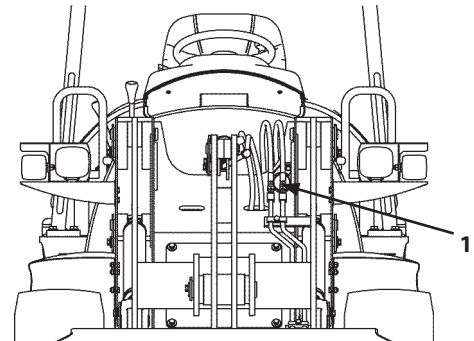

ME804-01-017

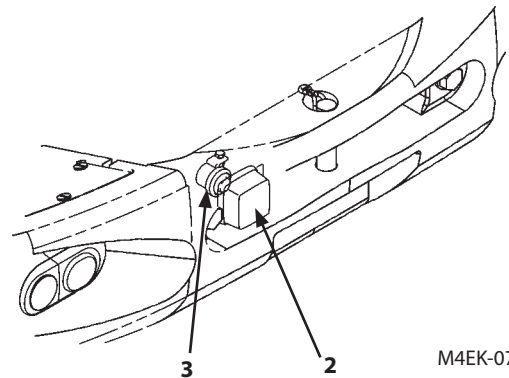

M4EK-07H-001



## MAINTENANCE

### 4 Check Electrical Harnesses and Fuses

--- every 50 hours

Check the electrical harness and terminals of the batteries, starter motor and alternator for loose connections and/or short circuit (broken shield). If any burned mark or an abnormal smell is noticed on a harness, consult your nearest authorized dealer.

#### Replace Fuse

1. If any electrical equipment becomes inoperable, first check the fuses in base machine fuse box (1) located on the back of the operator's seat.
2. One spare fuse for each respective fuse size is provided in the fuse box.
3. Finally, open the engine hood. Check slow blow fuses (2) located in the front of the batteries.

Slow blow fuses (2): 100 A (2 used)

Slow blow fuses (3): 65 A

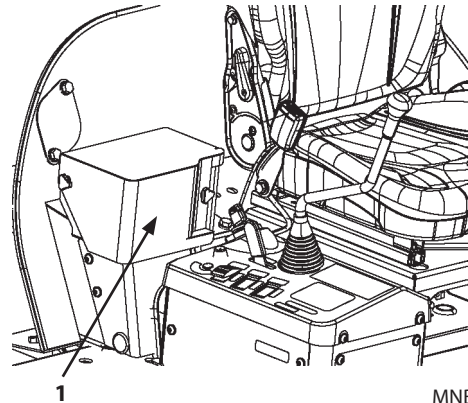

MNBC-01-017

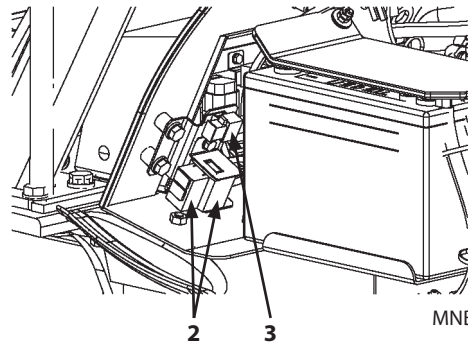

MNBC-01-018

## MAINTENANCE

### Fuse Box

No.	Amperes	Circuit
1	15 A	Headlight
2	-	(OP)
3	15 A	Hazard Lamp (OP)
4	5 A	Controller, Electronic Key (1) (OP), Tachograph (1)(OP)
5	30 A	Engine (1), ECM
6	5 A	Cab Light (Cab)
7	5 A	Engine (3), Airflow Sensor
8	15 A	Engine (2), EGR, Fuel Pump, Oil Separator
9	10 A	Key On, Electronic Key (2) (OP), Tachograph (2) (OP)
10	10 A	Discharge Warning Indicator, Alternator
11	(10 A)	Heater (Canopy) (FG Canopy) (OP)
12	(10 A)	Rear Work Light (Canopy) (OP)
13	(10 A)	Rotating Light, Alarm Light (Canopy) (OP)
14	5 A	Clearance Light, License Plate Light
15	10 A	Direction Indicator
16	15 A	Parking Brake, Backup Light, Backup Buzzer, HST Control, Travel Mode Switch (OP)
17	15 A	Bucket Auto Leveler
18	15 A	Horn, Brake Light
19	10 A	Instrument Light
20	-	-

 NOTE: Fuses with parentheses in the Amperes column are optional.

### Fuse Box (Cab-Equipped Machines) (Optional)

No.	Amperes	Circuit
1	30 A	Wiper Motor (Front) Washer Tank (Front)
2	20 A	Wiper Motor (Rear) Washer Tank (Rear)
3	10 A	Radio (OP)
4	15 A	Front Work Light (Cab) (FG Canopy)
5	10 A	Rear Work Light (Cab) (OP)
6	(10 A, 30 A)	Heater (10 A), AC (30 A) (OP)
7	(10 A)	A/C (2) (OP)
8	(10 A)	Rotating Light, Alarm Light (Cab) (FG Canopy) (OP)
9	-	(OP)
10	-	-

 NOTE: Fuses with parentheses in the Amperes column are optional.

## MAINTENANCE

### Battery

**⚠ WARNING:** Explosive gas is generated during use and/or charging of batteries. Keep sparks and Open flames away from batteries. Do not continue to use or charge the battery when electrolyte level is lower than specified. Explosion of the battery may result. Charge the batteries in a well ventilated location. Diluted sulfuric acid used for electrolyte is strong enough to burn skin and eats holes in clothing and metal. Always be careful when handling the batteries.

- Wear protective goggles
- Wear protective clothing

#### Avoid hazard by:

1. Filling batteries in a well-ventilated area.
2. Wearing eye protection and rubber gloves.
3. Avoiding breathing fumes when electrolyte is added.
4. Avoiding spilling or dripping electrolyte.
5. Using proper booster battery starting procedures.

#### If you spill acid on yourself:

1. Flush your skin with water.
2. Apply baking soda or lime to help neutralize the acid.
3. If splashed in eyes, flush with water for 10 to 15 minutes. Get medical attention immediately.

#### If acid is swallowed:

1. Do not induce vomiting.
2. Drink large amounts of water or milk.
3. Get medical attention immediately.

#### IMPORTANT:

- Add water to batteries in freezing weather before you begin operating your machine for the day, or else charge the batteries.
- If the battery is used with the electrolyte level lower than the specified lower level, the battery may deteriorate quickly.
- Do not refill electrolyte more than the specified upper level. Electrolyte may spill, damaging the painted surfaces and/or corroding other machine parts.

**🔧 NOTE:** If electrolyte is refilled more than the specified upper level line or beyond the bottom end of the sleeve, remove the excess electrolyte until the electrolyte level is down to the bottom end of the sleeve using a pipette. After neutralizing the removed electrolyte with sodium bicarbonate, flush it with plenty of water, otherwise, consult the battery manufacturer.

#### Precautions for Handling Batteries

**🔧 NOTE:** Battery negative terminal (with a red cover) at the base machine right side is the positive terminal.

- If electrolyte solution spills on your skin and/or clothes, immediately flush the skin and/or clothes with water and then wash with soap and water. If splashed in eyes, flush with water for approximately 15 minutes and seek immediate medical attention.
- Avoid using fire hazards such as matches lighters and tobacco near the batteries. Do not cause sparks.
- Check and service the batteries only after stopping the engine, turning the key switch OFF and removing the battery caps.



SA-032



SA-036

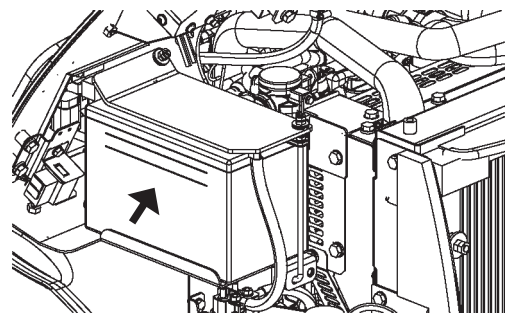

MNBC-07-012

## MAINTENANCE

---

- Working around the battery immediately after operation may cause personal injury. Wait for the battery to cool.
- When the battery is recharged, flammable hydrogen gas is created. Remove the battery from the machine. Recharge the battery after removing the caps in a well ventilated area.
- When disconnecting the battery terminals, first disconnect the ground line [minus (-)] side terminal. When connecting the battery terminals, connect the ground line [minus (-)] side terminal last. If a piece of metal, such as a tool comes in contact with the battery plus (+) side terminal and the vehicle frame when both terminals are connected, the electrical system may short-circuit, possibly creating a dangerous situation.
- Loose terminal may cause sparks to fly. Securely tighten the terminals.

## MAINTENANCE

---

### In case the batteries were discharged

**⚠ WARNING:**

- **Hydrogen gas is generated from batteries. Incorrect handling of the batteries may cause fires and/or explosion. Keep tobacco and/or open flame away from the batteries.**
- **If a metal tool is placed across the positive battery terminal and a vehicle component such as the engine block, sparks will fly, possibly resulting in fire and/or explosion.**
- **If electrolyte solution spills on your skin, scalding and/or blindness may be caused. Wear safety glasses, rubber gloves and a rubber apron whenever handling batteries.**
- **If electrolyte solution spills on your skin, immediately flush the skin with plenty of water and then seek immediate medical attention.**
- **Before checking the batteries, turn the key switch OFF to stop the engine and turn all switches OFF or neutral.**
- **Wear protective goggles**
- **Wear protective clothing**

**⚠ CAUTION:** When the batteries are removed, level the bucket to the ground. Apply the parking brake. Turn the key switch OFF to stop the engine. Be careful not to place metal tools on the batteries. To prevent sparks from flying, first disconnect the negative side (ground line) terminal. When connecting the batteries, connect the negative side terminal last.

**⚠ CAUTION:** When disposing of batteries, consult the shop where you purchased the batteries or a professional recycler. Do not dispose of the battery in a way that harms the environment.

### Method to recharge the removed battery

- Thoroughly read and understand the operation manual for the battery charger and follow the manual instructions.
- When charging the battery indoors, ventilate the area. Remove the battery caps to allow gas to be released.
- When charging the battery, keep fire hazards away from the battery. Do not allow a metal piece to come in contact with battery terminals.
- After the battery is charged, clean battery terminals and coat the terminals with grease before installing the battery on the base machine.

## MAINTENANCE

---

### **Method to Replace with Charged Auxiliary Batteries**

- Once the battery has been fully discharged, the service life of the battery is shortened. Replace such batteries with new ones at the earliest opportunity.
- Correctly and securely connect battery plus (+) post to cable plus (+) terminal and battery minus (-) post to cable minus (-) terminal respectively.

## MAINTENANCE

### 5 Check Electrolyte Level --- every 100 hours or 1 month

Check the electrolyte level at least once a month.

1. Park the machine on level ground and stop the engine.
2. Check the electrolyte solution level.
  - 2.1 When checking the level from the battery side:  
Clean around the level check lines with a wet towel. Do not use a dry towel. Static electricity may, causing the battery gas to explode. Check if the electrolyte solution level is between U.L (Upper Level) and L.L (Low level). In case the electrolyte solution level is lower than the middle level between the U.L and L.L, immediately refill with distilled water or commercial battery fluid. Be sure to refill with distilled water before recharging (operating the machine). After refilling, securely tighten the filler plug.
  - 2.2 When impossible to check the level from the battery side or no level check mark is indicated on the side:  
After removing the filler plug from the top of the battery, check the electrolyte level by viewing through the filler port. It is difficult to judge the accurate electrolyte solution level in this case. Therefore, when the electrolyte solution level is flush with the U.L, the level is correct. Referring to the illustrations to the right, check the level. When the electrolyte solution level is lower than the bottom end of the sleeve, refill with distilled water or commercial battery fluid up to the bottom end of the sleeve. Be sure to refill with distilled water before recharging (operating the machine). After refilling, securely tighten the filler plug.
  - 2.3 When an indicator is available to check the level, use this indicator to determine the fluid level.
3. Always keep the area around the battery terminals clean to prevent battery from discharging. Check terminals for looseness and/or corrosion. Coat the terminals with grease or petroleum jelly to prevent corrosion build up.

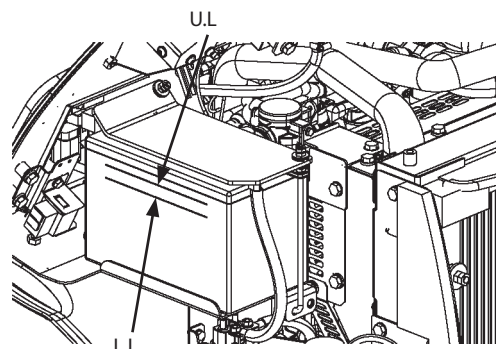

MNBC-07-012

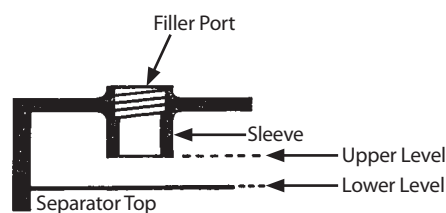

M4GB-07-093

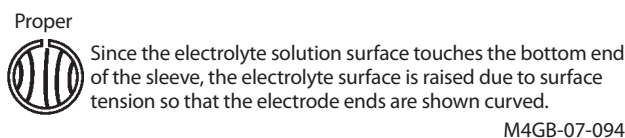

M4GB-07-094

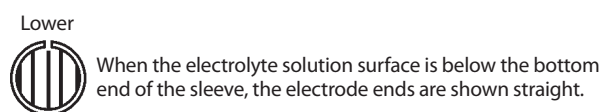

M4GB-07-095

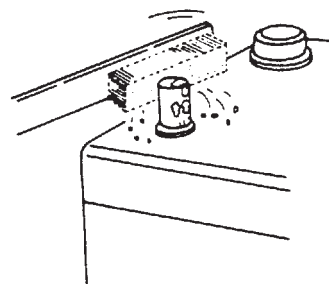

M4GB-07-096

## MAINTENANCE

### 6 Check Electrolyte Specific Gravity

--- every 250 hours or 3 months

The electrolyte specific gravity varies depending on the electrolyte temperature. The specific gravity should be kept within the range shown below. Charge the battery if the specific gravity is below the limit.

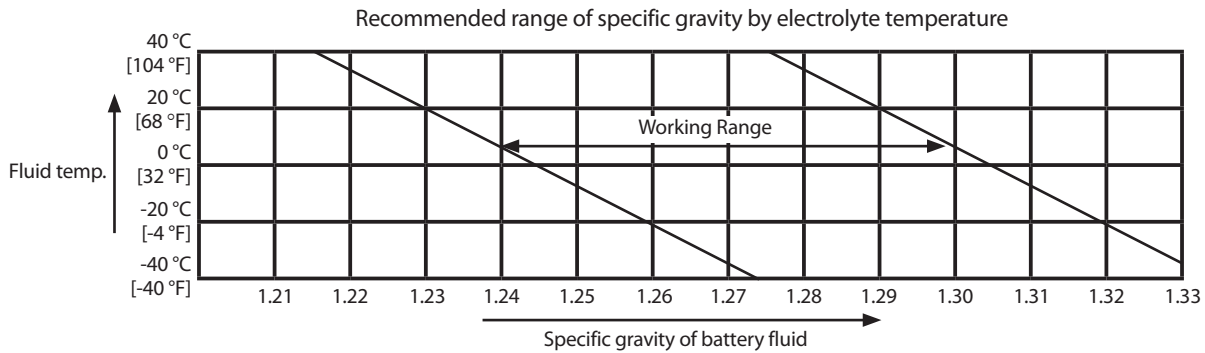

**NOTE:** Measure the electrolyte solution specific gravity when the electrolyte temperature is equal to the atmospheric temperature. Do not check the electrolyte solution specific gravity immediately after operation as the correct value can not be obtained.



# MAINTENANCE

## I. Brake System

- 1** Check Brake Oil Level  
--- every 10 hours (daily) or when the brake oil indicator comes ON

**! WARNING:** Do not continue to operate the machine with the brake oil level reduced, possibly resulting in personal injury or death. If the brake oil indicator comes ON, immediately stop operation of the machine.

Check if the brake oil level in brake oil tank (1) is correct. When the brake oil level is correct, it should be between MAX (2) and MIN (3) marks on brake oil tank (1).

If the oil level is lower than MIN (3) mark on brake oil tank (1), refill brake oil via cap hole on brake oil tank (1).

**IMPORTANT:** When the oil level in brake oil tank (1) is reduced, brake oil indicator (4) on the monitor comes ON. Immediately stop the machine. Check the oil level in brake oil tank (1) and check the brake system for any leaks.

**IMPORTANT:** Refill with the same brand of oil as described in the "kind of oils".  
If oil other than those described in the "kind of oils" is used, malfunction or failure of the brake may result.  
Automotive brake fluids will swell rubber parts and cause brake system failure.  
Use the correct brake oil.

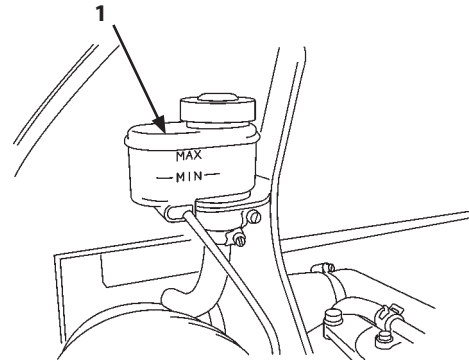

M4EK-071-001

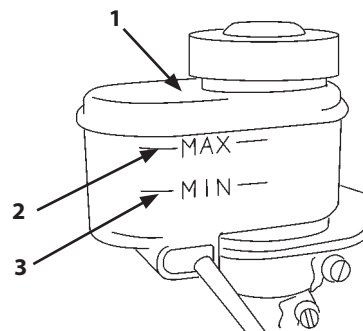

M4EK-071-002

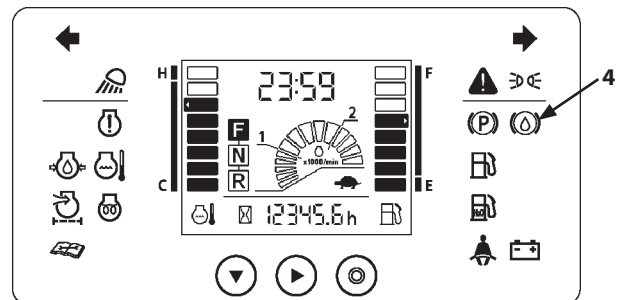

MNBC-01-024

## MAINTENANCE

### 2 Check Right and Left Brake Interlocking Performance

--- every 10 hours (daily)

**⚠ WARNING:** Put up a No Entrance notice 100 m ahead of the machine forward travel direction. Arrange a safety monitor person.

**⚠ WARNING:** Do not allow dust and/or soil to accumulate in vicinity of the brake pedal. The brake may lose traction.

While stepping on brake pedal (1), check the pedal movement, the brake performance and the play in the pedal stroke for any abnormality. If dust and/or soil accumulates in vicinity of the brake pedal, remove the accumulated dust and/or soil.

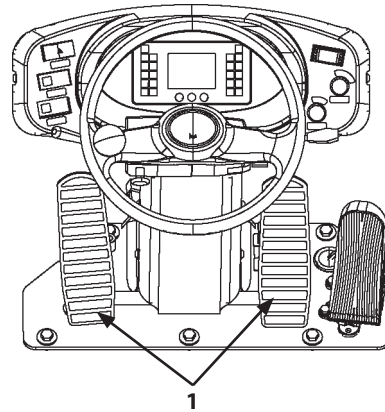

MNBC-01-007

#### Check brake performance

The machine must be stopped within 5 m range after the brake is applied while driving at the speed of 15 km/h on a flat dry paved surface road.

#### Check play in brake pedal stroke

Measure the pedal stroke at pedal tip by pressing the pedal with your hand until you feel an intermittent feed back force from the pedal.

Correct play (2): Approximately 10 mm

If the play is outside the specified range, or abnormal pedal operation and/or performance is noticed, consult your nearest authorized dealer. Get the machine checked and repaired.

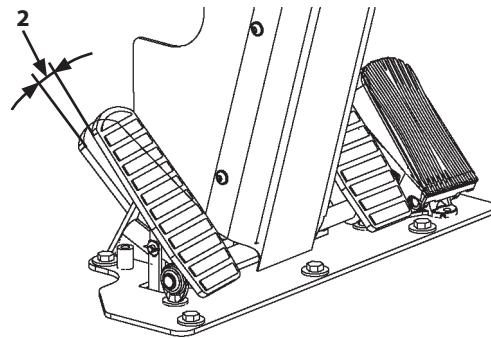

MNBC-07-016

## MAINTENANCE

### 3 Check Parking Brake Force --- every 10 hours (daily)

**⚠ WARNING:** Check the machine in a place where no one is present ahead in the traveling direction. Keep bystanders away from the machine.

**Condition: Empty bucket**

Park the machine with no load applied on a 15° inclined dry surface slope. The machine must not move with the parking brake switch (1) ON. Should the machine move during inspection, consult your nearest authorized dealer. Get the brake system checked and repaired.

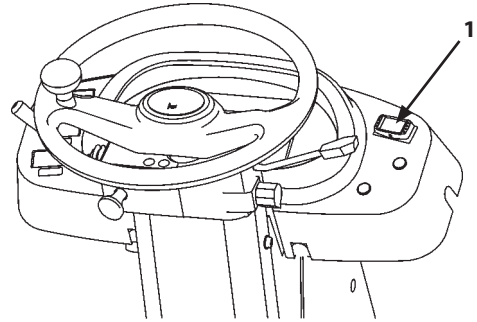

M4EK-01-006

### 4 Check Brake Disc (Service and Parking) --- every 1000 hours or 1 year

Wet disc type service brake and parking brake are mounted in the transmission. Consult your nearest authorized dealer for checking.

### 5 Change Brake Oil --- every 1000 hours or 1 year

Consult your nearest authorized dealer for changing brake oil.

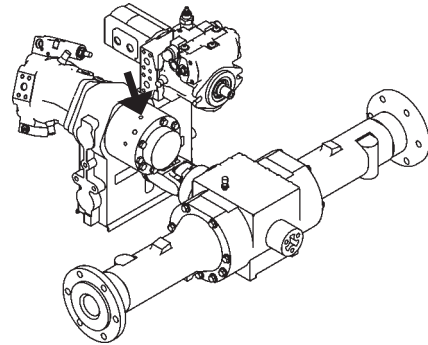

M4EK-071-005

## MAINTENANCE

### J. Tire

- 1** Check and Adjust Tire Pressure  
Check appearance --- every 10 hours (daily)  
Check tire pressure when appearance is questionable or each week (50 hrs.)  
Adjust --- as necessary

**! WARNING:** Secure the front and rear chassis with the articulation lock bar and pins. When inflating tires, stand behind the tire tread and use the self-attaching chuck. Avoid welding near tires and never weld rims, which could potentially cause the tires to explode. If the machine catches fire, tires may explode due to emission of heat if any sign of abnormality such as tire smoking, abnormal increase in tire temperature, or the air smells of rubber or tire bead burning is found.

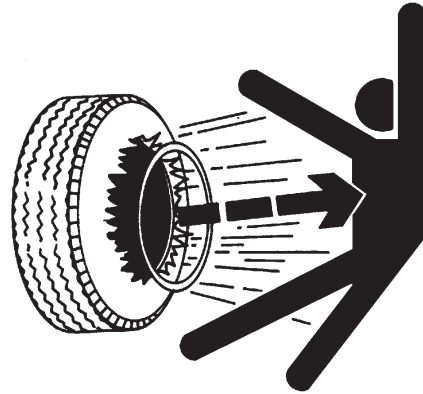

**IMPORTANT:** Always maintain the correct tire pressure. Even if only one tread pattern has worn out, replace the tire with a new one. Before operating the machine, check the tires for any breaks, damage or foreign matter. When replacing one tire, use a new tire having the same tread pattern, diameter and specification as the other tires.

SA-249

#### Check Tire Pressure

**! WARNING:** Pay attention not to allow tires to be used with excessively high or low pressure, possibly causing abnormal operation of the machine when traveling. In addition, cracks of the tires and cracks of the rims may result.

1. Measure air pressure when the tires are cool before operating the machine.

Standard Tire Size	Standard Air Pressure
15.5/60-18-8PR	220 kPa (2.20 kgf/cm <sup>2</sup> )

2. Check tires for any damage and/or excessive wear.

## MAINTENANCE

### 2 Check Tire for Damage --- every 10 hours (daily)

**WARNING:** If tire has external damaged such as a score, an accident due to puncture or burst of the tire may occur, possibly resulting in personal injury or death.

Check the external appearance of tires for any damage.

### 3 Check Wheel Bolt Torque --- every 500 hours (Only first time at 50 hours)

Be sure to check the wheel bolt torque by turning the bolt in the tightening direction.

Tightening Torque: 375 to 412 N·m  
(38.3 to 42.1 kgf·m)

#### Replace Tire

**CAUTION:** Secure the front and rear frames with the articulation lock bar and pins.

**IMPORTANT:** All over height of the machine may change according to the type of tires installed. Do not change the specifications of the registered machine.

1. Lower the bucket and lift arm to the ground. Apply the parking brake.
2. Secure the front and rear frames with the articulation lock bar and pins following the procedures described on page 7-6.
3. Loosen all wheel bolts one turn. Note which way the tread pattern is facing.
4. After jacking up the machine, securely support the machine with blocks.
5. Remove the wheel bolts. Replace the tire.
6. With the tire raised off the ground, lightly tighten the wheel bolts in the order as illustrated to the right.
7. Lower the machine to the ground. Retighten the wheel bolts to the specified torque value in the order as illustrated to the right.

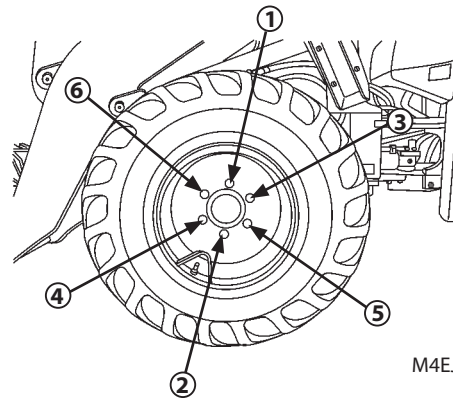

M4EJ-07M-003

## MAINTENANCE

---

### Tire sizes to be used

 *NOTE: Consult with your nearest authorized dealer about the optional tire patterns. The machine may vibrate depending on tire pattern. This is caused by resonance of the machine with the tire pattern, not by failure.*

Standard size	Standard air pressure
15.5/60-18-8PR	220 kPa (2.20 kgf/cm <sup>2</sup> )

 *NOTE: Regardless of tire patterns to be used, inflate the tire with the same air pressure shown above. Application instructions are belows.*

Adjust tire pressure conforming with the work mode the machine is engaged in.

Consult your nearest authorized dealer for more detailed information.

- Driving on public roads: Standard pressure
- Loading/excavation on normal ground surface: Standard or slightly higher than standard pressure
- Heavy-duty excavation: Higher pressure in the standard pressure range
- Operation on soft or sandy terrain: Slightly lower than standard pressure

Tire Pressure Adjustment Range:

220 to 260 kPa  
(2.20 to 2.60 kgf/cm<sup>2</sup>)

## MAINTENANCE

### Tire Rotation

Rotate tires when uneven or abnormal wear is recognized on either front or rear, or right and left tire. Tire rotation is recommended to achieve uniformity of wear on tires or equalization of tire service life.

### Rotation Method

**⚠ WARNING:** Install tire with no external damage such as scoring or abnormal wear. Failure to do so may cause a puncture or tire blowout, possibly resulting in personal injury or death since tire load is increased when the machine is loaded or stopped when operated.

- Switch tires only between the front and rear positions. Do not switch the tires between diagonal positions.
- Align the tire rotation direction with the tire tread design pattern. The traction design pattern (optional) will affect not only economy of the tire but also safety of operation.

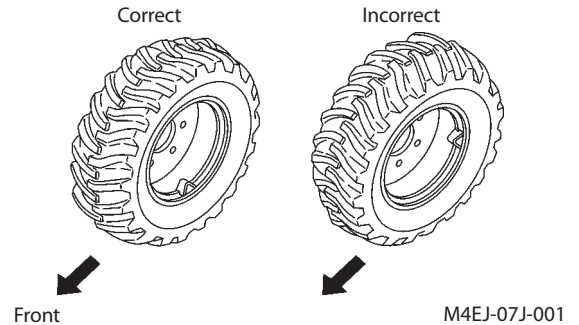

### How to Check Wear Amount (Tread Design Groove Depth)

Measure the groove depth at position of 1/4 tread width [shown with X mark (1) in the figure].

Use limit of the groove depth shall be approx. 85 % of the new tire groove depth. In case extreme uneven wear or exposed rubbing strips are found, replace the tire even before reaching 85 %.

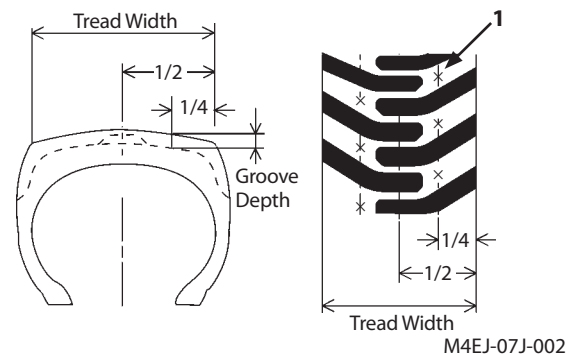

**IMPORTANT:** If the machine is operated with tires at either rear or front being extremely worn or different in type, construction, or size, the travel driving system such as axles or transmission will be adversely affected in their performance and/or endurance. Avoid operating the machine under such conditions. When replacing tires, be sure to use the same tires in type, construction and size on all four wheels. It is recommended to replace all four tires at the same time.

## MAINTENANCE

---

### Removal and Installation of Tire

**⚠ WARNING:** Mounted tire assembly is a very heavy part so that removal and installation of tire is hazardous and difficult work. In addition, a crane to lift the tire is required when removing or installing the tire to the wheel. Consult your nearest authorized dealer or professional tire sales shop for tire removal and installation work. In case jacking up the machine is required, be sure to observe the following points.

- Select dry, solid and level ground for work site.
- Work in groups of more than two personnel. One person shall mainly engage in the repair work and others shall work as assistants and/or to ensure safety.
- Do not use the bucket to raise the front wheels.
- Do not raise the machine off the ground more than necessary.
- Chock tires as required.
- After the machine is raised off ground, be sure to block the machine using rigid supports. Never leave the machine supported only by jacks.
- The rear wheels oscillate. Insert wooden blocks between the axle and the frame to stop oscillation.
- When removing the wheel bolts, lift the wheel with a crane so that the wheel bolt remaining at the top position should be the last to be removed.
- Refer to **3** Check Wheel Bolt Torque for the wheel bolt tightening torque value.

### Tire Wheel

**⚠ WARNING:** When a tire must be dismantled from the rim, ask a professional tire shop to do so. Allow only an authorized tire shop to inflate a tire after the tire was installed onto the wheel. Remove rust from the wheel. Severe rust may caused cracks, possibly resulting in the machine and/or personal accident. Rim cracks may be shown by development of rust.



## MAINTENANCE

---

### K. Air Conditioner

**1** Check Air Conditioner for Damage  
--- every 6 months

Check the heater mounting and hoses for any damage.

 **NOTE:** When the cold season approaching, check the heater before it is actually required to be sure it is operable at any time. When the heater is not used for a long period of time, use heater once a week to keep it operational.

**2** Check Heater Piping  
--- every 6 months

Check the heater piping for any abnormal deformation and/or damage. If a pipe joint become contaminated, check the joint for water leaks.

 **CAUTION:** If any water leak is found, repair or replace the corresponding parts.

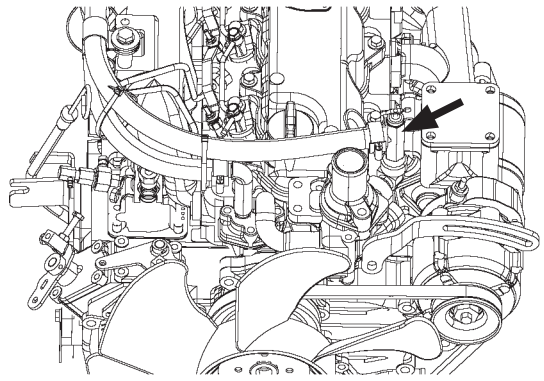

MNBB-07-008

## MAINTENANCE

### 3 Clean and Replace Circulation Air Filter for Air Conditioner

**Clean Circulation Air Filter --- every 250 hours (or once a month whichever comes first)**

**Replace Circulation Air Filter --- after cleaning 6 times (or when restricted excessively)**

 **NOTE:** When the machine is operated in dusty work site, shorten intervals of cleaning and/or replacement.

#### Clean circulation air filter

 **WARNING:** Wear safety glasses or goggles when using compressed air.

**IMPORTANT:** The filter may be damaged if high pressure compressed air is used. When using compressed air for cleaning purpose, reduce air pressure to lower than 0.2 MPa (2 kgf/cm<sup>2</sup>)

1. Removing the filter  
Circulation air filter is located inside the left seat support. Remove four screws (2) and cover (3). Remove circulation air filter (1) by pulling it up through the opening.
2. Cleaning circulation filter (1)  
Clean circulation air filter (1) by spraying compressed air.
3. When reinstalling the cleaned filter or installing a new filter, follow the reverse procedure as described in above step 1 (Removing the filter).

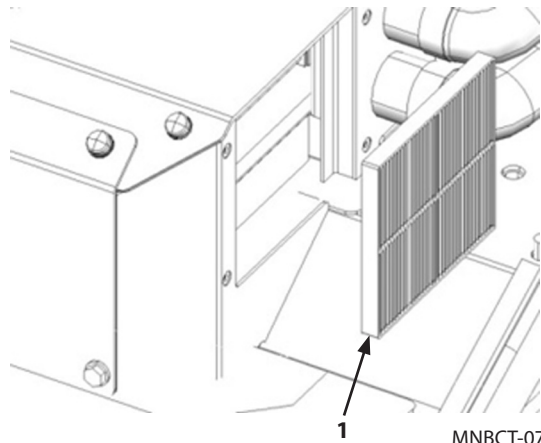

MNBCT-07-006

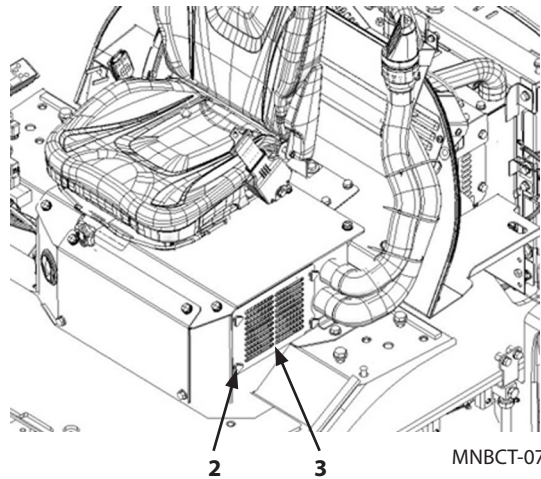

MNBCT-07-007

## MAINTENANCE

---

### **4** Check Air Conditioner Unit --- every 6 months

Check the air conditioner switch panel, the air conditioner unit, the condenser and the hoses for any abnormality.

 **NOTE:** *Inspect the air conditioner prior to the in-season to allow it to be operable at any time. During off-season when the air conditioner is not in use for a long period of time, perform cooling operation once a week to prevent the lubrication parts of the air conditioner from becoming dry due to lack of lubricant.*

### **High Temperature Pressure Cleaning (Steam Cleaning)**

 **WARNING:** Do not clean the compressor and the receiver tank with steam. Failure to do so may cause the refrigerant pressure to increase, possibly resulting in breakage of hoses.

### **5** Check Pipelines --- every 6 months

Check pipelines for abnormal deformation and damage. In case a contamination is found at a joint of the pipeline, leakage of the refrigerant is suspected. Check for leak of the refrigerant using a detector.

 **CAUTION:** If a leak of refrigerant is found, repair or replace the necessary parts and tighten them to specification. Do not only retighten the pipelines if they are leaking since the leaks need required.

## MAINTENANCE

### 6 Check Air Conditioner Condenser --- every 6 months

If condenser (1) is contaminated with dust or debris, cooling performance will be reduced. Remove cover (2) from the top of condenser (1). Wash fins on condenser (1) to remove dust and contamination with tap water. Use a brush if seriously contaminated. Do not use a hard brush, possibly causing damage to fins. Be careful not to bend or damage fins.

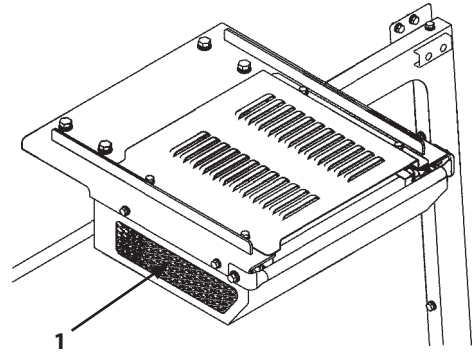

M4EK-AC-005

### 7 Check Air Conditioner Drive Belt --- every 6 months

Check the belt for abnormal deflection and any damage. Check the deflection by pressing the midpoint (with mark ↓) of the belt with the force of approx. 30 N (3 kgf).

Normal deflection: approx. 9 mm

#### Adjusting Compressor Drive Belt Tension

1. Loosen lock nut (4) on tension pulley (5).
2. Turn tension adjust bolt (3) for tension pulley (5) to adjust belt tension.
3. Tighten nut (4).

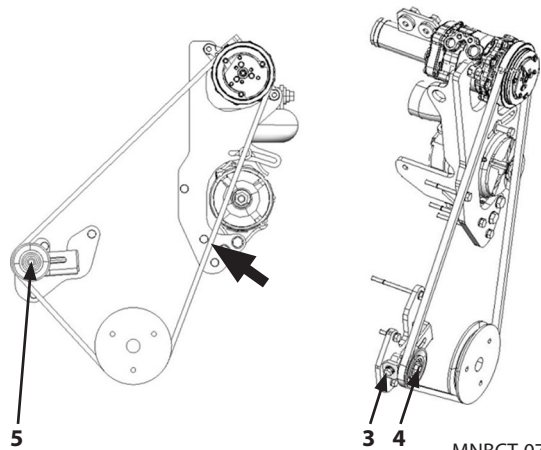

MNBCT-07-008

## MAINTENANCE

### 8 Check Refrigerant Quantity --- every 6 months

After performing cooling operation for 2 to 3 minutes with the engine running at 1500 min<sup>-1</sup> (rpm), check the refrigerant through sight glass (checking window) (1). Refrigerant R134a has been adapted on this machine as refrigerant. Supply new refrigerant by correct quantity only after withdrawing the residual refrigerant thoroughly. If any abnormality is found on the air conditioner, consult your nearest authorized dealer.

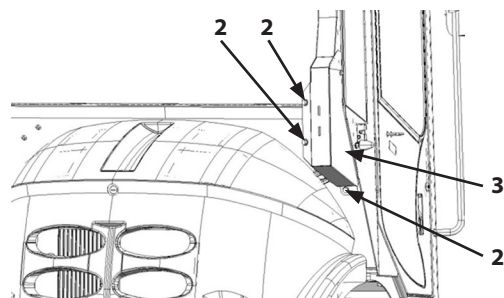

MNBCT-07-009

Type	Refrigerant No.	Quantity
HFC	R134a	1.0 ± 0.05 kg

**IMPORTANT: Do not allow the refrigerant to escape into the atmosphere. Protect the ozone.**

### 9 Check Compressor and Pulley --- once a year

Check the surrounding areas around the compressor for signs of oil leaks, abnormal mounting conditions and/or operation, and refrigerant leaks. Check if the pulley is making excessive noise.

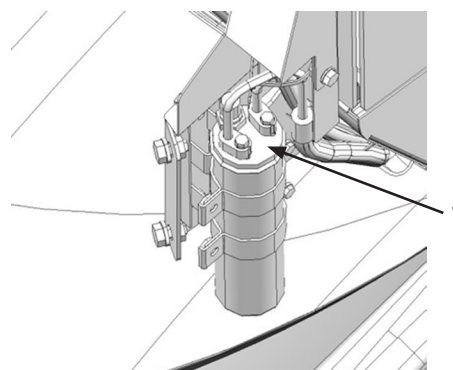

MNBCT-07-010

#### Check the compressor

After performing cooling operation for 5 to 10 minutes, carefully touch both the high and low pressure side pipelines. Normally the high-pressure side is hot and the low-pressure side is cool. If not, consult your nearest authorized dealer.

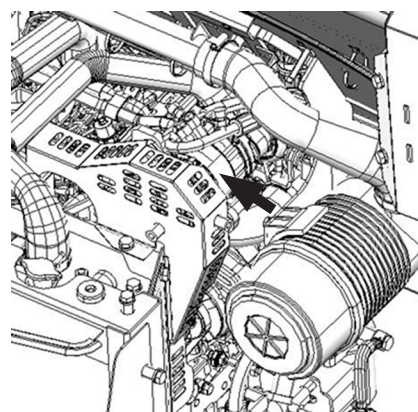

MNBCT-07-011

### 10 Check Switch Operation --- once a year

Check that all switch functions are normal. Perform combined operation of the switches to check the air conditioner function. (Refer to the descriptions of the air conditioner operation procedures.)

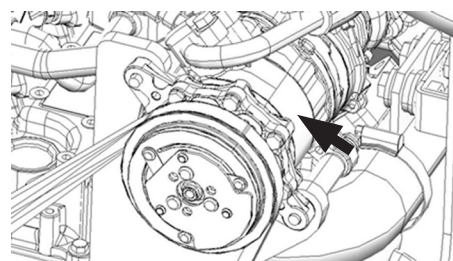

MNBCT-07-012

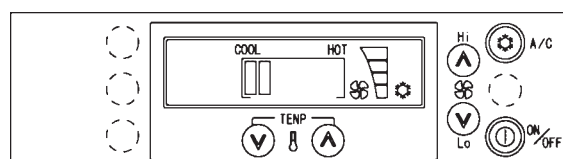

M4EK-AC-001

## MAINTENANCE

### L. Miscellaneous

#### 1 Check Bucket Bolt-On Cutting Edge for Tightness and/or Wear

--- every 10 hours (daily)

Check the bucket cutting edge for wear and tightness.

#### Replacement

**⚠ WARNING:** Guard against injury from flying pieces of metal. Wear protection such as safety glasses and a hard hat when servicing the machine.

1. Raise the bucket to an appropriate height with the bucket bottom supported with blocks.

**✎ NOTE:** Raise the bucket so that the bucket bottom is level.

2. Loosen bolts (1) and nuts (2). Remove cutting edge (3).
3. Install new cutting edge (3). If the reverse side of cutting edge is not worn much, use it again with the unused edge forward. If both sides are worn out, replace with a new one.

Tighten nuts (2) to specified torque.  
Tightening torque: 186.2 to 235.2 N·m  
(19 to 24 kgf·m)

4. Retighten mounting nuts (2) after several hours of operation.

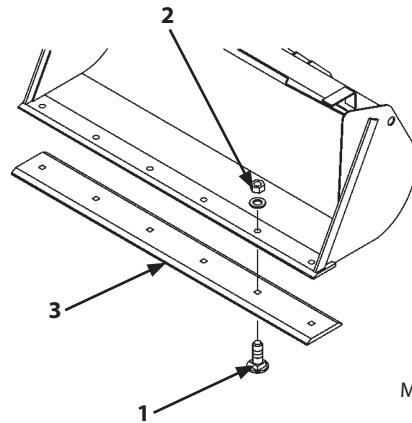

M4EJ-07L-001

## MAINTENANCE

### 2 Check and Replace Seat Belt Check --- every 10 hours (daily) Replace --- every 3 years

Examine seat belt tongue (1), buckle (2) and seat belt. Replace the damaged or worn parts. Check if the seat belt is correctly reeled in. Replace the seat belt every 3 years, regardless of appearance.

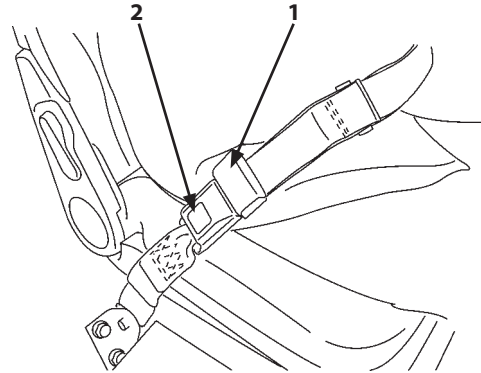

M4EJ-01-041

### 3 Check Canopy/Cab for Damage and Mounting Bolts for Tightness --- every 10 hours (daily)

Check the appearance of canopy resin roof (3) and for any abnormal damage or deformation. Check mounting bolts (4) for tightness.

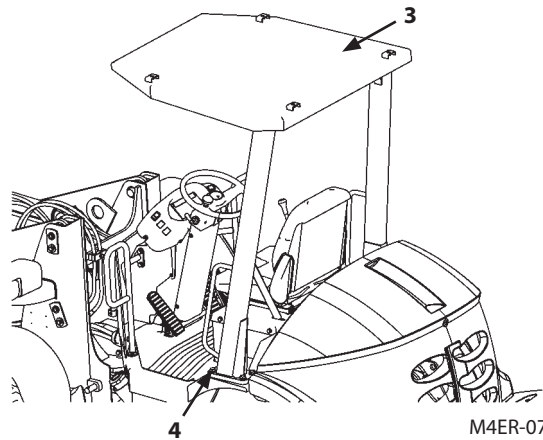

M4ER-07-003

### 4 Check Windshield Washer Fluid Level (Cab Equipped Unit) --- every 10 hours (daily)

Check the fluid level. If necessary, add window washer fluid.

**IMPORTANT: Keep all dirt, dust and other foreign materials out of the tank. Use antifreeze washer fluid in cold weather.**

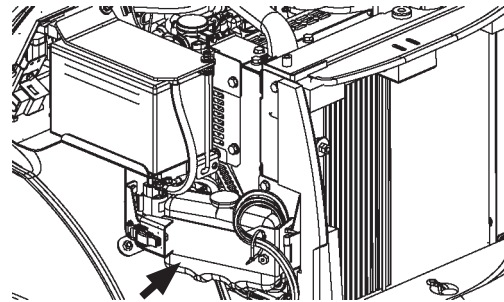

MNBC-07-013

## MAINTENANCE

### 5 Check Play in Steering Wheel Stroke

--- every 10 hours (daily)

**⚠ WARNING:** When the steering wheel is turned, clearance between the front and rear chassis becomes narrower, possibly creating a pinch point hazard. Keep all personnel away from the articulation joint during inspection.

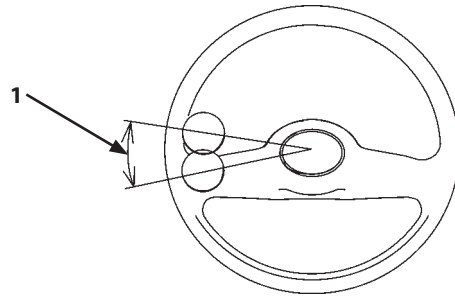

M4EJ-07L-004

Check that play (1) in steering wheel stroke is correct. In addition, check that the rear chassis contacts steering stopper when the steering wheel is fully turned and that the steering cylinders operate normally.

1. Start the engine. Turn the parking brake switch ON.
2. Slightly lift the bucket above the ground. Place the pilot control shut-off lever in the LOCK position.
3. While running the engine at slow idle, slowly rotate the steering wheel knob both clockwise and counterclockwise. Measure the moving distance along the steering wheel circumference until both right and left steering cylinders start moving (check the movement of the bucket and/or tires).  
Allowable play (1): 20 to 40 mm

**✎ NOTE:** If steering wheel play is excessive or if steering wheel does not move smoothly, consult your nearest authorized dealer for inspection.



## MAINTENANCE

### 6 Check Accelerator Pedal Operation, and Exhaust Gas Color and Noise

--- every 10 hours (daily)

**WARNING:** Move the forward/reverse selector lever to neutral. Apply the parking brake. After leveling and resting the bucket on the ground, set the wheel chock blocks.

While slowly stepping on accelerator pedal (1), check if the engine speed increases smoothly. Then, while slowly returning accelerator pedal (1), check that the engine speed decreases smoothly.

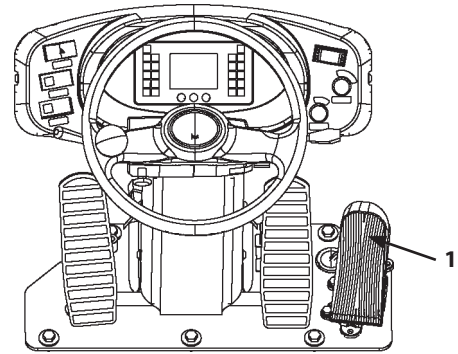

MNBC-01-007

### Exhaust Gas Color and Noise

**DANGER:** Ventilate the shop with fresh air when carrying out warm-up operation indoors. Failure to do so may cause inhalation of the exhaust gas, possibly resulting in death or serious injury.

Exhaust gas color is normally transparent or light blue. Although exhaust gas becomes a light black color immediately after the engine is started or quickly accelerated, this symptom is not abnormal. If the exhaust gas color becomes black, white, brown, or gray, check the engine oil level and the fuel supply system for abnormality. In addition, check that no abnormal noise is heard coming from the engine or muffler.

## MAINTENANCE

### 7 Check Outside and Inside Rearview Mirrors

--- every 10 hours (daily)

Check that inside rearview mirror (1) and outside rearview mirror (2) (on the cab equipped machine) are facing in the correct direction. Check inside rearview mirror (1) and rearview mirror (2) for contamination or damage.

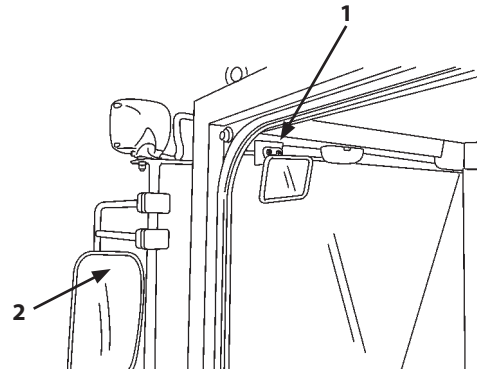

M4EK-07L-002

### 8 Check Steps and Handrails for Damage and Tightness

--- every 10 hours (daily)

Check steps (3) and handrails (4) for damage, tightness and contamination. If any slippery matter such as machine lubricants or mud sticks to the steps and/or handrails, remove such contaminants. If the steps and/or handrails become damaged or loosened so that getting on and off the machine is difficult, immediately tighten or replace.

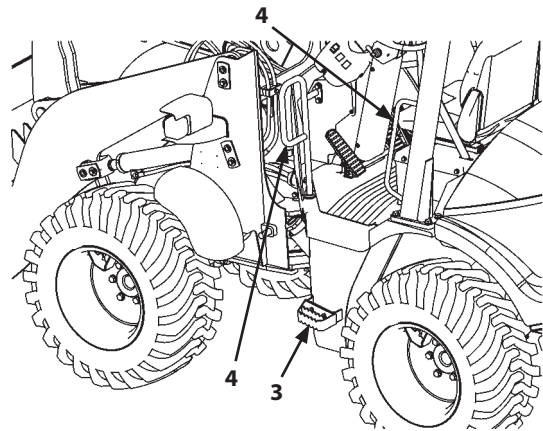

M4ER-01-005

### 9 Clean Engine Compartment and Hood

--- every 10 hours (daily)

**CAUTION:** Debris or chips accumulated in the engine compartment or around the hood may come in contact with high temperature sections near the engine or hood, possibly causing fires.

Open the hood and check if debris and/or chips are accumulated in the engine compartment and/or the areas above the engine. Remove the accumulated debris and chips from under the hood.

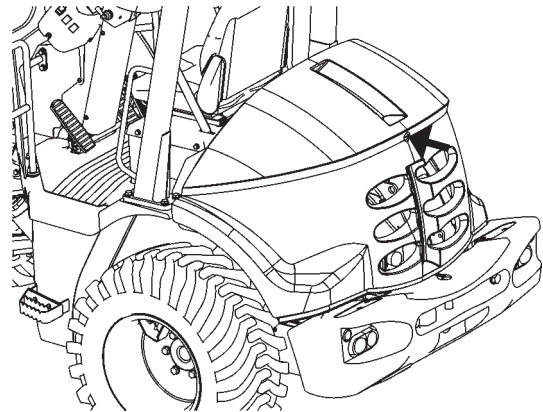

M4ER-01-004

## MAINTENANCE

---

### **10** Check and Adjust Valve Clearance

--- every 1000 hours or 1 year

Consult your nearest authorized dealer for inspection and repair.

### **11** Check Sound Absorbing Mat Around Engine

--- every 1000 hours or 1 year

**⚠ CAUTION:** If the sound absorbing mat in the engine compartment loosens, the mat may come in contact with the high temperature sections of the engine, possibly resulting in fires.

Check if the sound absorbing mat around the engine has loosened. If any part of the mat is found loose, immediately contact your nearest authorized dealer for repair.

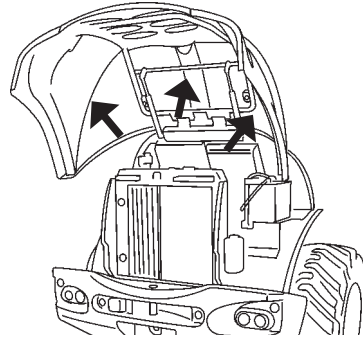

M4EK-01-056

### **12** Check Fuel Injection Timing

--- every 1000 hours (or 1 year whichever comes first)

Consult your nearest authorized dealer for inspection and repair.

## MAINTENANCE

---

- 13** **Check Engine Compression Pressure**  
--- every 1000 hours (or 1 year whichever comes first)

Consult your nearest authorized dealer for inspection and repair.

- 14** **Check and Clean Starter and Alternator**  
--- every 1000 hours or 1 year

Consult your nearest authorized dealer for inspection and repair.

- 15** **Retighten Front Axle and Rear Axle Support Mounting Bolts**  
--- every 1000 hours (Only first time at 50 hours)

Check the front and rear axle support mounting bolts or tightness.

### **Tightening torque values of the front axle and rear axle support mounting bolts**

Front Axle Mounting Bolt	Rear Axle Support Mounting Bolt
418 to 460 N·m (42.6 to 46.9 kgf·m)	188 to 229 N·m (19.2 to 23.4 kgf·m)

## MAINTENANCE

### Tightening and Retightening Torque of Nuts and Bolts







Tighten or retighten nuts and bolts used on this machine in accordance with the torque values shown in the following table. Check nuts and bolts for tightness and verification that they are in place before and after operation. If any loose or missing nuts and/or bolts are found retighten or supply replacement parts. The nuts and bolts other than those shown in the table below shall be tightened in accordance with the torque values shown in the table on page 7-88.

Use LOCTITE #262 and apply torque values shown with mark \*.

	Tightening location	Bolt Dia.	Quantity	Wrench Size	Torque N·m (kgf·m)
1	Front axle mounting bolt	20	4	30	*418 to 460 (42.6 to 46.9)
2	Rear axle support mounting bolt	16	4	24	*188 to 229 (19.2 to 23.4)
3	Wheel rim mounting bolt	18	24	27	375 to 412 (38.3 to 42.1)
4	Front propeller shaft mounting bolt	12	8	19	*113 to 123 (11.5 to 12.5)
5	Rear propeller shaft mounting bolt	8	8	13	*30 to 36 (3.04 to 3.72)
6	Transmission mounting bolt: Bracket	12	6	19	*83.4 to 93.2 (8.5 to 9.5)
7	Transmission mounting bolt: Rubber cushion	12	4	19	*44.1 to 53.9 (4.5 to 5.5)
8	Engine mounting bolt: Rear bracket	12/10	7/1	19/17	*83.4 to 93.2 (8.5 to 9.5) *49.0 to 53.9 (5.0 to 5.5)
9	Engine mounting bolt: Front bracket	10	8	22	*49.0 to 53.9 (5.0 to 5.5)
10	Engine mounting bolt: Rubber cushion	12	4	19	*83.4 to 93.2 (8.5 to 9.5)
11	Counterweight mounting bolt	24	3	36	698 to 768 (71 to 78)
12	Center pin top locking	12	4	19	*77.3 to 94.4 (7.8 to 9.6)
13	Center pin bottom plate locking	12/16	4/1	19/24	*77.3 to 94.4 (7.8 to 9.6)/ *188.3 to 229.5 (19.2 to 23.4)
14	Steering cylinder pin locking	10	4	17	44.1 to 53.9 (4.5 to 5.5)
15	Radiator frame mounting nut (Nut/Lock nut)	10	4	17	17.7 to 21.5 (1.8 to 2.2)/ 14.7 to 16.6 (1.5 to 1.7)
16	Cutting edge mounting nut	16	6	24	245.2 to 294.2 (25 to 30)

## MAINTENANCE

### Tightening Torque Chart

Bolt Dia. mm	Hexagon Wrench						Socket Bolt			
							Wrench size mm	Socket Bolt		Wrench size mm
	N·m	(kgf·m)	N·m	(kgf·m)	N·m	(kgf·m)		N·m	(kgf·m)	
6						3.3 to 4.2 (0.3 to 0.4)	10			5
8	30	(3.0)	20	(2.0)	10	(1.0)	13	20	(2.0)	6
10	65	(6.5)	50	(5.0)	20	(2.0)	17	50	(5.0)	8
12	110	(11)	90	(9.0)	35	(3.5)	19	90	(9.0)	10
14	180	(18)	140	(14)	55	(5.5)	22	140	(14)	12
16	270	(27)	210	(21)	80	(8.0)	24	210	(21)	14
18	400	(40)	300	(30)	120	(12)	27	300	(30)	14
20	550	(55)	400	(40)	170	(17)	30	400	(40)	17
22	750	(75)	550	(55)	220	(22)	32			
24	950	(95)	700	(70)	280	(28)	36			
27	1400	(140)	1050	(105)	400	(40)	41			
30	1950	(195)	1450	(145)	550	(55)	46			
33	2600	(260)	1950	(195)	750	(75)	50			
36	3200	(320)	2450	(245)	950	(95)	55			

**⚠ CAUTION:** If counterweight mounting bolts are loosened, consult your nearest authorized dealer.

**IMPORTANT:**

- Apply lubricant to bolts and nuts to lower friction.
- Remove soil, dust, and/or dirt from the nut and bolt thread surfaces before tightening.
- Tighten nuts and bolts to specifications. If tightened with excessively low or high torque, missing or breakage of nuts and/or bolts may result.

## MAINTENANCE

### 1. Front axle mounting bolt

Bolt diameter	20
Quantity	4

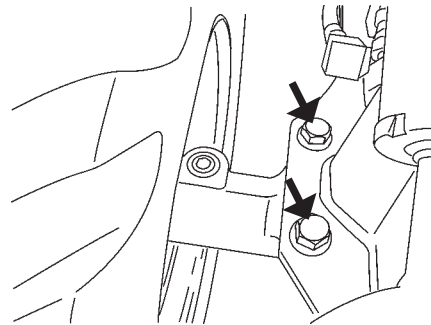

M4EJ-07M-001

### 2. Rear axle support mounting bolt

Bolt diameter	16
Quantity	4

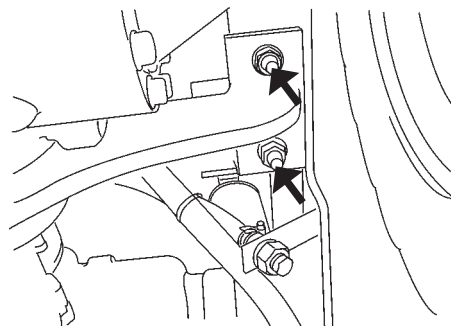

M4EJ-07M-002

### 3. Wheel rim mounting bolt

Bolt diameter	18
Quantity	24

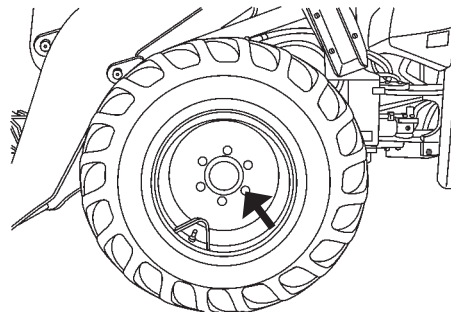

M4EJ-07M-003

## MAINTENANCE

### 4. Propeller shaft mounting bolt

Bolt diameter	12
Quantity	8

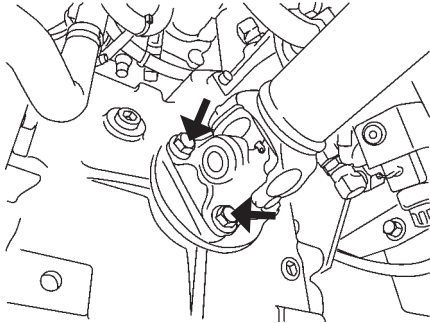

M4EJ-07A-010

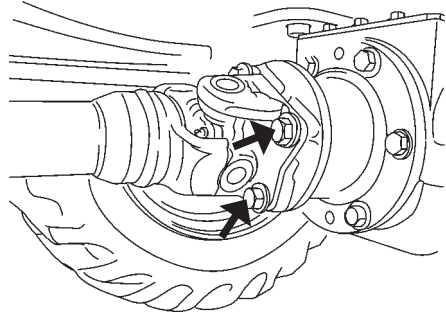

M4EJ-07A-009

### 5. Rear propeller shaft mounting bolt

Bolt diameter	8
Quantity	8

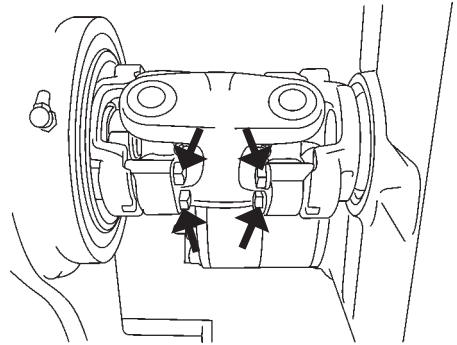

M4EJ-07A-011

### 6. Transmission mounting bolt: Bracket

Bolt diameter	12
Quantity	6

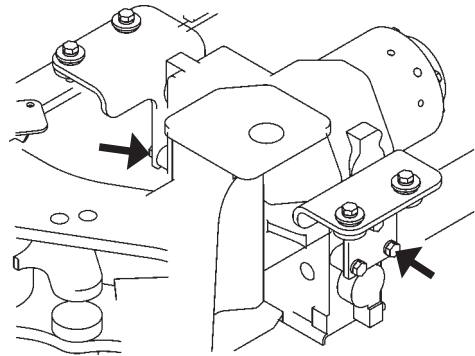

M4EK-07M-003



## MAINTENANCE

### 7. Transmission mounting bolt: Rubber cushion

Bolt diameter	12
Quantity	4

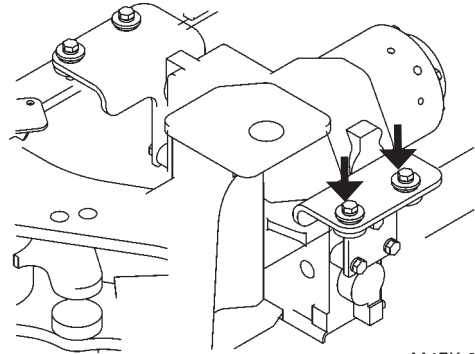

M4EK-07M-003

### 8. Engine mounting bolt: Bracket (Rear)

Bolt diameter	12	10
Quantity	7	1

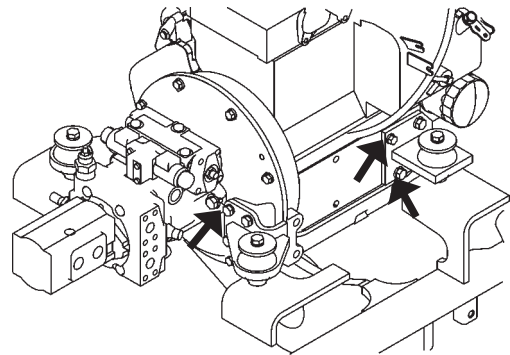

M4EK-07M-002

### 9. Engine mounting bolt: Bracket (Front)

Bolt diameter	10
Quantity	8

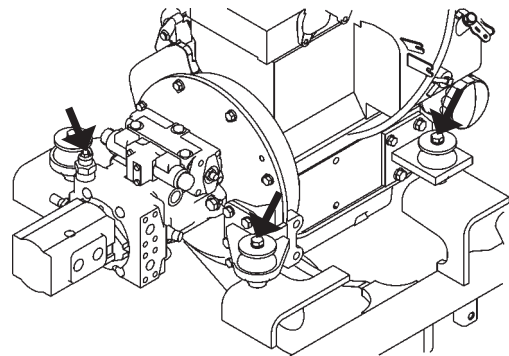

M4EK-07M-002

### 10. Engine mounting bolt: Rubber cushion

Bolt diameter	12
Quantity	4

## MAINTENANCE

### 11. Counterweight mounting bolt

Bolt diameter	24
Quantity	3

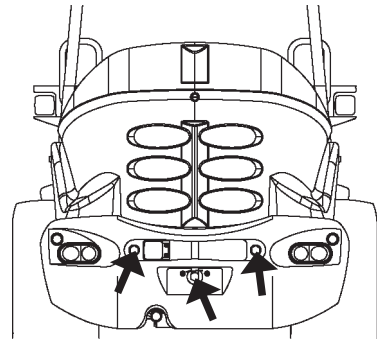

M4ER-07-004

### 12. Center pin top locking

Bolt diameter	12
Quantity	4

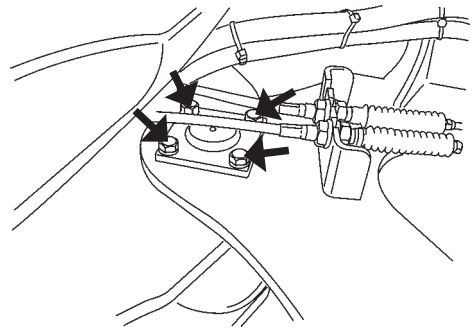

M4EJ-07M-010

### 13. Center pin bottom locking

Bolt diameter	12	16
Quantity	4	1

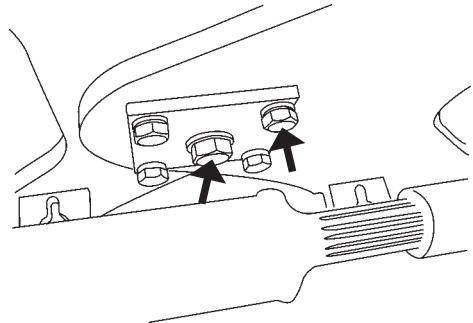

M4EJ-07M-011

### 14. Steering cylinder pin locking

Bolt diameter	10
Quantity	4

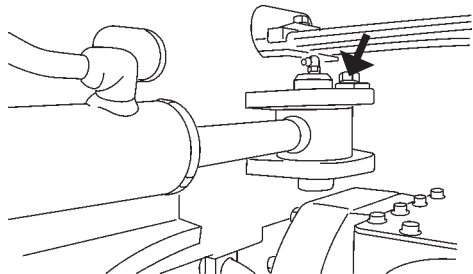

M4EJ-07A-004

## MAINTENANCE

### 15. Radiator frame mounting nut

Bolt diameter	10
Quantity	4

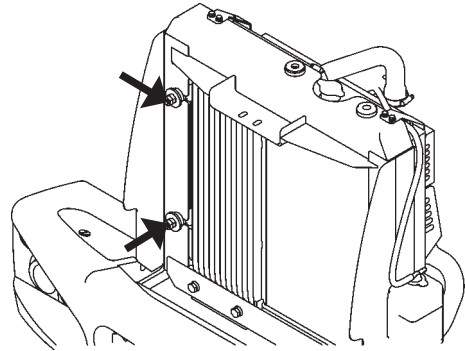

M4EK-07M-001

### 16. Cutting edge mounting nut

Bolt diameter	16
Quantity	6

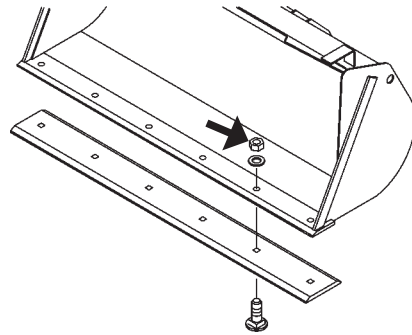

M4EJ-07L-001



## MAINTENANCE UNDER SPECIAL ENVIRONMENTAL CONDITIONS

### Maintenance Under Special Environmental Conditions

Operating Conditions	Precautions for Maintenance
Muddy Soil, Rainy or Snowy Weather	<p>Before Operation: Check tightness of plugs and all drain cocks.</p> <p>After Operation: Clean the machine and check for cracks and damage. Check for loose or missing bolts and nuts. Lubricate all necessary parts.</p> <p>If the machine should be submerged in water, water may get into the brake device (like the parking brake), resulting in poor braking performance. Watch out when starting/stopping the machine.</p>
Near the Ocean	<p>Before Operation: Check tightness of plugs and all drain cocks.</p> <p>After Operation: Thoroughly clean the machine with fresh water to wash off salt. Service electrical equipment often to prevent corrosion.</p>
Dusty Atmosphere	<p>Air Cleaner: Clean the element regularly at shorter service intervals.</p> <p>Radiator: Clean the oil cooler screen to prevent clogging of the radiator core.</p> <p>Fuel System: Clean the filter element and strainer regularly at shorter service intervals.</p> <p>Electrical Equipment: Clean them regularly, in particular, the commutator surface of the alternator and starter.</p>
Rocky Ground	<p>Chassis: Check for damage on tires, for loose, cracked, worn, and damaged bolts and nuts.</p> <p>Front Attachment: Standard attachment may be damaged when digging rocky ground. Use a heavy duty bucket.</p>
Freezing Weather	<p>Fuel: Use high quality fuel suitable for low temperature. Check the fuel tank breather pipe freezing.</p> <p>Lubricant: Use high quality low viscosity hydraulic oil and engine oil.</p> <p>Engine Coolant: Be sure to use antifreeze.</p> <p>Battery: Fully charge the batteries regularly at shorter service intervals. If not charged fully, electrolyte may freeze.</p> <p>Tires and Frames: Keep tires and frames clean. Park the machine on a hard surface to prevent the tires from freezing to the ground.</p>
When handling old paper and/or industrial waste	<p>Engine compartment: Remove old paper and/or waste accumulated around the radiator and in the engine compartment, possibly causing overheating or fires of the machine if not removed.</p> <p>Air cleaner: Clean the element at shorter intervals.</p> <p>Fuel system: Clean and replace the elements and the filters at shorter intervals.</p> <p>Loader frame: Remove the accumulated paper and/or waste from the surroundings around the loader frame and the attachment. Failure to do so may cause damage of the machine.</p> <p>Radiator: Wash as frequently as possible to prevent corrosion due to chemical materials.</p>

 **WARNING:**

- **Before operating the machine in a river, check the riverbed conditions in advance. Avoid driving the machine into a river where the riverbed is steep and deep or the stream is rapid.**

## MAINTENANCE UNDER SPECIAL ENVIRONMENTAL CONDITIONS

---

### Precautions for Maintenance During Cold Weather Season

Before the atmospheric temperature lowers below 0 °C (32 °F), note the following points.

- Water and oil in the machine will freeze.
- Road surfaces will freeze so that tires may slip.

Keeping the above points in mind, follow the advisement below:

1. Refill fluids such as water and lubricants prior to operation.
2. Mix LLC (long life coolant) in the radiator (coolant). When this machine is shipped from the factory, LLC is supplied.
3. Change the engine oil in the engine crankcase to cold weather type oil.
4. Use fuel (diesel #1) of an antifreeze type. To prevent condensation in the fuel tank, fully refill the fuel tank with #1 diesel fuel after each shift.
5. If the electrolyte solution in the battery case freezes, damage to the battery case may result. Maintain the batteries at fully charged condition. After completing work, turn all lights OFF. Run cooling cycle for five minutes. Another option is to dismount the batteries and store them in a warm place. When it is possible to measure and adjust the specific gravity of the electrolyte solution, increase the specific gravity of the electrolyte up to 1.280. Do not increase more than 1.280.
6. Use anti-freeze type washer fluid

After taking the measures as recommended above, start operation of the machine.

 **WARNING: Ventilate the shop with fresh air when carrying out warm-up operation indoor. Failure to do so may cause intoxication by exhaust gas, possibly resulting in death or serious injury.**

7. After preheating the engine, start the engine. Perform warm-up.

## MAINTENANCE UNDER SPECIAL ENVIRONMENTAL CONDITIONS

---

8. After warming up the engine, cycle the front attachment system. Slowly operate the control levers to move the cylinders full stroke several times.
9. Road surfaces covered with snow, especially when snow has been compacted, will be frozen. Use tire chains on four wheels.
10. Take anti-freeze measures after completing operation.
  - Cover the keyhole by sticking a tape on.
  - Rubber parts such as wipers may freeze. Keep other parts away from the rubber parts. Thoroughly heat cab prior to operating machine.
  - Remove packed snow from around the undercarriage and inside the machine with a bar or brush. Be careful not to damage electrical wiring.
  - In case it is impossible to store the machine indoors, park the machine on a level dry surface and cover overall the machine with a large machine cover.





## STORAGE

### Storing the Machine

**⚠ WARNING:** In case lubrication is performed indoors, open windows and doors to maintain good air ventilation to prevent asphyxiation. Lubricant property will deteriorate even if the machine is kept stored. Check all lubricants before operating the machine after bring stored. Apply the parking brake while storing.

If the machine is to be stored for more than one month, observe the following precautions so that its function will not be impaired during storage.

#### PRECAUTION ITEMS FOR LONG-TIME STORAGE

	Contents of Work
Wash Machine	Wash the machine to remove mud and/or dust.
Supply Oil and Grease	Check for low level/contamination of lubricating oil. Grease all joints. Apply a thin coat of oil to parts susceptible to rust (i.e. cylinder rods etc.)
Battery	Remove and fully charge the battery, then store it in a warm place.
Coolant	Supply a rust preventive agent. If there is a possibility of freezing, also use an antifreeze solution or fully drain the coolant. In this case, be sure to attach a "No Water in Radiator" sign in the operator's cab.
Prevention of Dust and Moisture	Store the machine in a dry garage and cover it.
Tools	Inspect and repair, then store.
Lubrication No-load Operation at a Slow Speed for Several Minutes	If the oil films of the parts are broken and parts are rusted, they will cause damage when operated. To prevent this, operate the machine at least once a month to lubricate the parts. At this time, check the coolant and lubrication oil levels.

**IMPORTANT:** If the machine is operated without performing lubrication operation, damage to hydraulic equipment may result due to insufficient lubrication.

**✎ NOTE:** *Lubrication operation means that a series of operations such as drive, and loader front operation are repeated a few times after performing the warm-up operation. Before operating the loader front attachment and steering wheel, remove rust prevention oil coated on the hydraulic cylinder rods.*

*All electronic settings, such as radio station settings and HVAC system controller settings, must be reset due to battery removal.*

## STORAGE

---

### Removing the Machine from Storage

**⚠ WARNING:** In case lubrication is performed indoors, open windows and doors to maintain good air ventilation to prevent asphyxiation. Lubricant property will deteriorate even if the machine is kept stored and not run. Check all lubricants before operating the machine after bring stored. Apply the parking brake while stored.

**IMPORTANT:** Lubricants will deteriorate during storage of the machine. Thoroughly check coolant, lubricants and adequately perform lubrication operation before resuming operation. Avoid quick operation. Failure to do so may cause damage to the engine, hydraulic equipment, transmission, axle, etc. due to insufficient lubrication or coolant.

1. Remove grease from the cylinder rods if coated.
2. Adjust alternator and fan belt tension.
3. Fill the fuel tank. Bleed air from the fuel system. Check all fluid levels.
4. Start the engine.  
Run the engine at half speed for several minutes until operating temperature is reached before full load operation.
5. Cycle all hydraulic functions several times, being careful not to fully stroke cylinders.
6. Carefully check all systems before operating the machine at full load.

**✎ NOTE:** When the machine has been stored for a long time, be sure to perform the following steps as well:

- (a) Check condition of all hoses and connections.
- (b) Warm up the engine.
- (c) Stop the engine.
- (d) Install new fuel filters. Replace the engine oil filter and fill the engine oil to the full mark on the oil level dipstick.

Before operating, check the machine in accordance with the descriptions on "Check before starting" on page 3-1 and warm-up.

## TROUBLESHOOTING

### Troubleshooting

If any machine trouble has occurred, immediately repair it. Make certain the cause of the trouble and take necessary measures to prevent the reoccurrence of the same trouble. In case troubleshooting is difficult, or measures marked with \* must be taken, consult the nearest authorized dealer. Never attempt to adjust, disassemble, or repair the hydraulic and/or electrical/electronic parts/components.

#### 1. Engine

Consult the nearest authorized dealer for the engine troubleshooting.

#### 2. Engine Auxiliaries

Problem	Cause	Solution
<b>Batteries will not charge.</b>	Broken battery separator Faulty regulator Faulty ground line Faulty alternator	Replace * Adjust and replace * Repair * Repair and replace
<b>Batteries discharge quickly after being charged.</b>	Shorted cable Shorted battery separator Increased sediment in battery	* Repair and replace * Replace * Replace
<b>Coolant temperature is too high.</b>	Low coolant level Loose engine fan V-belt Damaged rubber hose Faulty thermostat Faulty coolant temperature gauge Cooling system passages dirty Radiator core or oil cooler core plugged Radiator screen plugged	Add * Adjust * Replace * Replace * Replace Flush cooling system Clean radiator and oil cooler Clean screen

#### 3. Engine does not Start.

Symptom	Cause	Solution
<b>The starter does not turn.</b>	Reduced battery voltage High resistance in the starter circuit  Faulty key switch Damaged wire harness Faulty battery relay Blown slow blow fuse link The forward/reverse selector lever is in either the forward or reverse position. Faulty starter	Charge the batteries. Replace. * Clean and/or retighten the battery terminals and starter terminals * Replace * Repair or replace * Replace * Replace Return to neutral. * Repair or replace
<b>Although the starter turns, the engine does not start.</b>	Use of poor quality fuel, insufficient fuel, lack of fuel Faulty glow plug Air mixed in the fuel supply line Faulty injection pump or nozzle Reduced compression pressure	Change fuel. Refill tank with good quality fuel * Replace glow plug Bleed air * Repair or replace * Repair or replace
<b>Engine speed does not increase.</b>	The accelerator pedal function is abnormal.	Replace accelerator pedal or parts.
<b>Although the engine cranks, running speed is low and easy to stall.</b>	Deteriorated engine oil Contaminated injection nozzle Clogged fuel filter Clogged feed pump strainer Air mixed in the fuel supply line Poor fuel quality.	Change engine oil * Replace Replace Clean Bleed air Replace

Items with \* mark: Consult your nearest authorized dealer.

## TROUBLESHOOTING

### 4. Hydraulic Control Lever

Symptom	Cause	Solution
<b>Hard to move</b>	Rusted joint Worn pusher	* Lubricate or repair * Replace
<b>Does not move smoothly</b>	Worn pusher Faulty control valve	* Repair or replace * Replace
<b>Does not return to neutral</b>	Faulty control valve	* Replace
<b>The lever is tilted in the neutral position due to increase in play</b>	Worn joint Faulty control valve	* Repair or replace * Replace
<b>The lever is not held with magnetic detent.</b>	Faulty magnetic solenoid Faulty sensor	* Replace * Replace

Items with \* mark: Consult your nearest authorized dealer.

### 5. Hydraulic System

After the machine has been kept stored for a long time, air in the oil may be separated and accumulate in the upper section in the cylinder, causing slow response time in operation or reducing cylinder power. In case these symptoms appear, repeatedly operate all actuators several times.

Problem	Cause	Solution
<b>Loader front and travel functions are inoperable (hydraulic pump noise level increases).</b>	Faulty hydraulic pump Lack of hydraulic oil Broken suction pipe and/or hose	* Repair, Replace Refill * Repair, Replace
<b>All actuators have no power.</b>	Malfunction due to worn hydraulic pump Decrease in set pressure of main relief valve in control valve Lack of hydraulic oil Trapped foreign matter in hydraulic oil tank suction filter Aeration in suction side	* Replace * Clean and Adjust Refill Clean or Replace Retighten
<b>Only one actuator is inoperable.</b>	Broken control valve spool Trapped foreign matter in valve spool Broken pipe and/or hose Loose pipe line joint Broken O-ring at pipe line joint Broken actuator	* Replace * Repair, Replace * Repair, Replace Retighten * Replace * Repair, Replace
<b>Only one cylinder is inoperable or has no power.</b>	Broken oil seal in cylinder Oil leak due to damage to cylinder rod	* Repair, Replace * Repair, Replace
<b>Oil overheats</b>	Clogged oil cooler Weak tension of engine fan belt	Clean or Replace Adjust
<b>Oil leak from low pressure hose</b>	Loose clamp Faulty suction manifold	Retighten * Repair, Replace

 **NOTE:** \* Consult the nearest authorized dealer.

## TROUBLESHOOTING

6. Drive Function		
Problem	Cause	Solution
<b>Steering wheel is heavy to operate.</b>	Faulty hydraulic pump Faulty steering device Relief valve set pressure reduction Faulty steering column Low tire air pressure	* Repair, Replace * Repair, Replace * Adjust * Repair, Replace * Inflate
<b>Steering wheel turns in unexpected direction.</b>	Faulty steering device	* Repair, Replace
<b>Accelerator pedal is heavy to operate.</b>	Rusted joint	* Lubricate, Repair
<b>Accelerator pedal play is excessive.</b>	Worn joint	* Replace, Repair
<b>Parking brake The brake does not release (sticking, dragging).</b>	Oil leak due to failure of D-ring on the parking brake piston Faulty brake disk	* Repair or replace * Repair or replace
<b>Parking brake Does not work properly</b>	Damaged disk brake spring Faulty disk brake Scored or seized piston or worn disk	* Replace * Replace * Repair or replace
<b>Service brake does not work properly</b>	Malfunction of brake valve Oil leak from brake line, Air mixing	* Repair or replace * Repair. Bleed air
<b>Service brake is dragging.</b>	Malfunction of brake valve Faulty brake pedal Corrosion of brake pedal parts Pebbles in area of brake pedal	* Repair or replace * Repair or replace Clean and lubricate Remove - clean area
<b>Service brake fluid loss.</b>	Oil leak from brake line and/or hose connector Oil leak due to brake piston seal (inside axle)	* Retighten or repair * Repair
<b>Transmission is noisy.</b>	Lack or deterioration of gear oil Worn inner parts in transmission Broken gear or bearing	Refill, replace * Repair, Replace * Repair, Replace
<b>Propeller shaft vibrates.</b>	Bent propeller shaft Loosened parts, Loss of balance	* Replace * Retighten, Adjust or Replace
<b>Propeller shaft is noisy</b>	Excessively worn spline Worn or seized spider bearing Loosened parts Insufficient greasing	* Replace * Replace * Retighten Grease
<b>Front and/or rear axle is noisy</b>	Worn or broken gears Lack or deterioration of gear oil Worn bearings, Excess play Excess play on shaft spline	* Replace Refill, Replace * Replace * Repair, Replace
<b>Front and/or rear axle does not transmit power.</b>	Broken axle Broken gears	* Repair * Repair

 **NOTE:** \* Consult the nearest authorized dealer.

### 7. Others

The machine may have a noise, excessive vibration, and abnormal smell when any trouble occurs. Always beware of the machine conditions during operation.

# TROUBLESHOOTING

---

---

## MEMO

A series of horizontal dotted lines for taking notes.

## SPECIFICATIONS

### Specifications

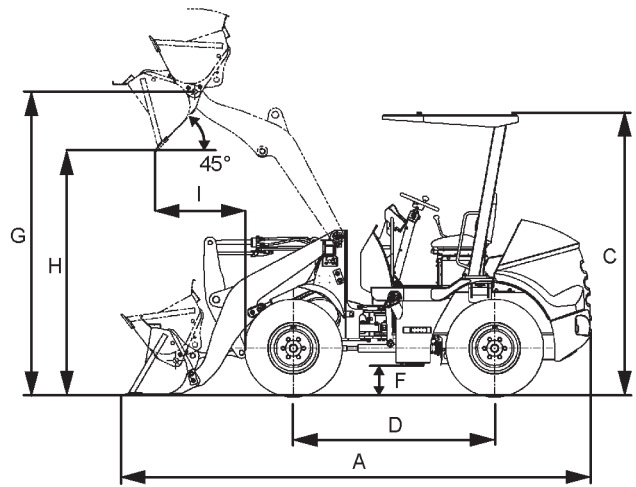
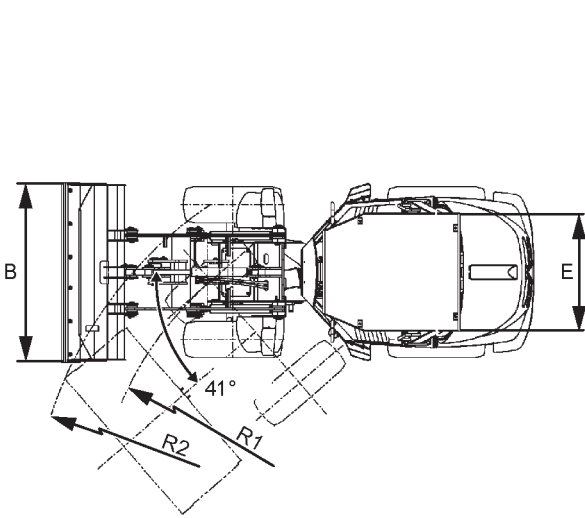

MNBB-12-001

Model	—	ZW50-5B
Bucket Capacity: heaped	m <sup>3</sup>	0.6 (BOC)
Operating Weight (Canopy/Cab)	kg	3760/4000
Rated Loading Weight	kg	980
Engine Model	—	Kubota D1803-CR-TIE4B
Engine Flywheel Power (SAE J1995 Gross)	—	30.1 kW/2200 rpm
A: Overall Length	mm	4665
B: Overall Width (Bucket)	mm	1690
C: Overall Height (Canopy/Cab)	mm	2565 /2595
D: Wheel Base	mm	1850
E: Tread	mm	1260
F: Ground Clearance	mm	295
G: Bucket Hinge Height	mm	3140
H: Dumping Clearance (45°)	mm	2500
I: Dumping Reach (45°)	mm	870
R1: Minimum Rotation Radius	mm	3125
R2: Minimum Rotation Radius	mm	3815
Travel Speed Forward/Reverse	km/h	15/15
Transmission Speeds (F/R)	—	1/1
Articulation Angle (Left/Right) deg	(°)	41
Tire Size	—	15.5/60-18-8PR (L2)

**NOTE:** The specifications can change at any time.

# SPECIFICATIONS

---

---

## MEMO

Dotted lines for writing content.



## OPTIONAL ATTACHMENTS

### Handling Quick Coupler (Mechanical Type)

**⚠ WARNING: During work, keep other persons away from the machine.**

The quick coupler is a system with which a front attachment work tool such as a bucket can be easily replaced with other work tool.

#### Removal

**⚠ WARNING: Before leaving the machine, apply the parking brake.**

Disconnect all hydraulic hoses routed to the attachment cylinders except for the bucket and lift arm cylinders. (Refer to page 13-3 for "Connection/disconnection of Hydraulic Hoses".)

If possible, place the bucket (attachment) to be removed on a pallet.

1. Horizontally raise the bucket (attachment) about 20 cm above the pallet.
2. Remove quick coupler lock pin (1). Turn lever (2) to removal position (3) to remove coupler pins (5) (right and left).
3. After checking that coupler pins (5) (right and left) have been removed, install lock pin (1) in hole (6) to lock lever (2) in position.
4. Place the bucket (attachment) to as close rear end of the pallet as possible so that the quick coupler can be easily removed.
5. While tilting the bucket forward, slightly lower the arm. The bucket (attachment) is removed from the quick coupler. Take your time and proceed with care.

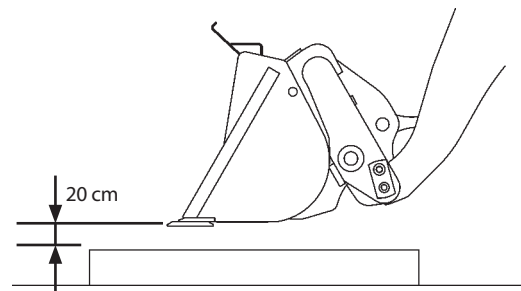

M4EK-13-001

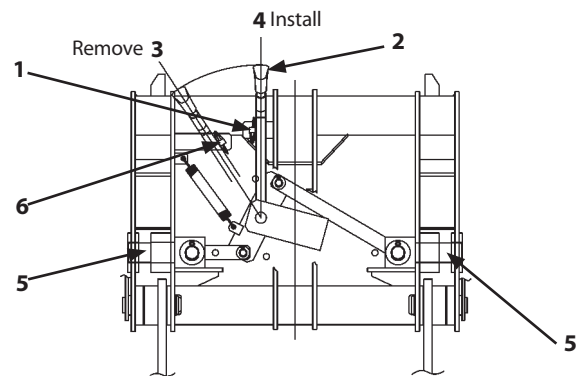

M4EK-13-002

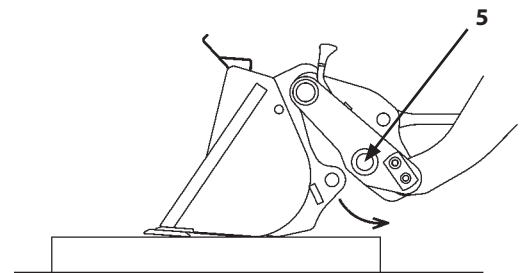

M4EK-13-003

## OPTIONAL ATTACHMENTS

### Installation

**⚠ WARNING:** Be sure to complete installation work only after checking that coupler pins (5) (both right and left) have been installed.

**⚠ WARNING:** Before leaving the machine, apply the parking brake.

1. After checking that coupler pins (5) have been removed. Slowly approach the machine to the bucket (attachment) hooks (6) until the hooks are inserted into the quick coupler.
2. Slightly raise lift arm (7) to slowly allow the bucket (attachment) to tilt backward until stopper (8) on the bucket comes in contact with quick coupler stopper (9).
3. Remove lock pin (1). Return lever (2) to installation position (4) to install coupler pins (5) (right and left).
4. After checking that coupler pins (5) (right and left) have been securely installed, set lock pin (1) in the original position.

In case an attachment to be installed is actuated by a hydraulic cylinder other than the bucket and/or the lift arm, do not disconnect the hydraulic hoses from the attachment cylinder.

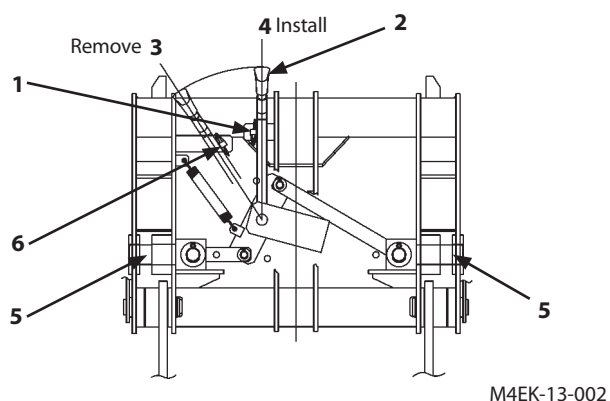
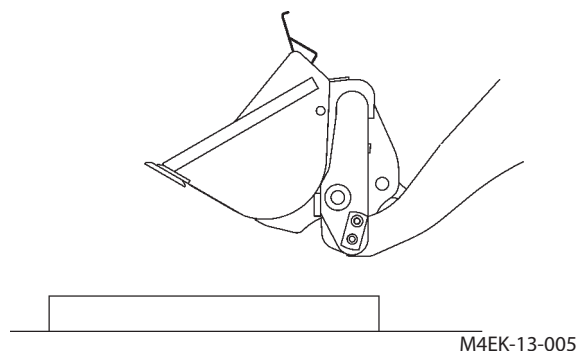
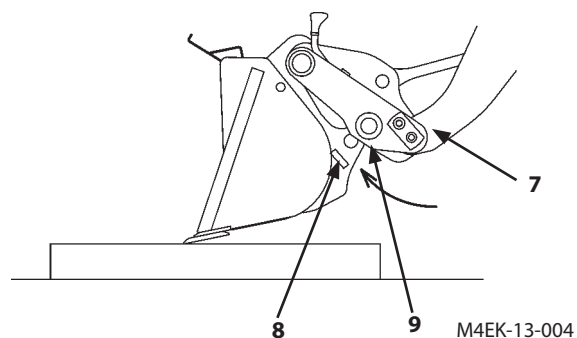
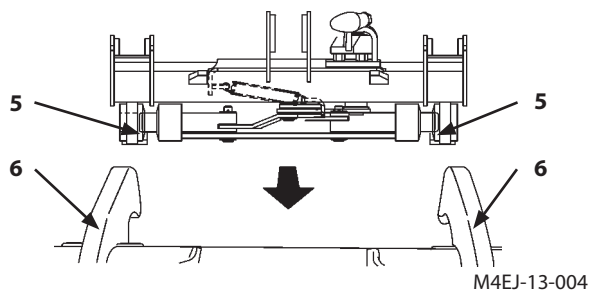

## OPTIONAL ATTACHMENTS

### Disconnecting/connecting hydraulic hose quick connectors

When activating an attachment with a hydraulic cylinder other than the lift arm cylinder or bucket cylinder using the machine hydraulic pressure oil, hydraulic quick connectors must be connected or disconnected. At this time, connect or disconnect the hydraulic hoses following the procedures below.

#### Procedures

**CAUTION:** Before starting to work, apply the parking brake and stop the engine. Operate the attachment control lever several strokes to release any hydraulic oil pressure remaining in the circuits.

**IMPORTANT:** Thoroughly remove dirt and oil from the hydraulic hose connectors.

- Connect the attachment hydraulic hoses to the machine hydraulic pipe lines.
- After connecting the hydraulic hoses, start the engine. While operating the attachment control lever, slowly move the attachment. Check for oil leaks from the hydraulic hose connectors.
- When the attachment is removed, joint the attachment hose female end to the male end. Put dust caps to the machine hydraulic pipe line female and male ends to prevent the pipe line ends from becoming contaminated.

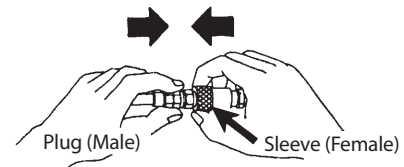

When connecting hoses, insert the plug while pulling the sleeve. When the sleeve is returned, the hose connectors are automatically locked and connected.

M4GB-13-007

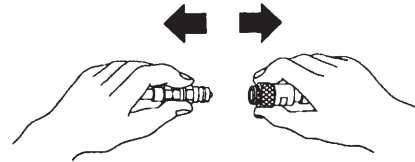

When disconnecting the hoses, pull the sleeve. The connectors are instantaneously separated.

M4GB-13-008

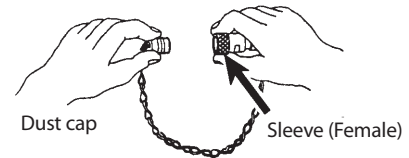

When installing the dust cap to or removing the dust cap from the female type hose end, pull on the sleeve.

M4GB-13-009

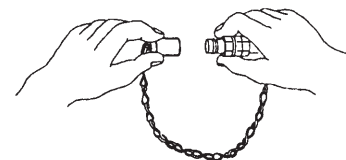

When installing the dust cap to the male type hose end, just connect it to the hose end.

M4GB-13-010

## OPTIONAL ATTACHMENTS

---

---

MEMO

Dotted lines for memo content.

## INDEX

<b>A</b>	
Accelerator Pedal.....	1-29
Adjust Fan Belt Tension .....	7-54
Adjust Operator's Seat .....	5-6
Adjusting the Operator's Seat (Reclining Type).....	1-38
Adjustment of Bucket Auto Leveler.....	5-3
Air Cleaner .....	7-50
Air Cleaner Restriction Alarm (Red) .....	1-10
Air Conditioner .....	7-75
Air Conditioner (Optional) Operation .....	1-35
Articulation Lock Bar .....	1-50
Avoid Accidents from Backing Up and Turning .....	S-16
Avoid Applying Heat to Lines Containing Flammable Fluids .....	S-33
Avoid Heating Near Pressurized Fluid Lines .....	S-33
Avoid High-Pressure Fluids .....	S-29
Avoid Injury from Rollaway Accidents.....	S-15
Avoid Overloading.....	5-5
Avoid Positioning Bucket or Attachment Over Anyone.....	S-17
Avoid Power Lines.....	S-19
Avoid Rapid Steering Changes and/or Sudden Braking.....	5-5
Avoid Tipping.....	S-17
<b>B</b>	
BREAK-IN.....	2-1
Basic Operation.....	1-55
Before Operation.....	5-4
Beware of Asbestos and Silica Dust and Other Contamination.....	S-34
Beware of Exhaust Fumes.....	S-32
Bluetooth® Input.....	1-62
Brake Level Low Indicator .....	1-9
Brake System.....	7-67
Brake/Inching Pedal .....	1-29
<b>C</b>	
COMPONENTS NAME.....	1-1
Cab Door.....	1-47
Cab Switch Panel (Optional).....	1-46
Cab Vehicle (Optional) .....	1-2
Canopy Vehicle.....	1-1
Change Axle Oil.....	7-27
Change Brake Oil.....	7-69
Change Coolant .....	7-55
Change Engine Oil .....	7-23
Change Hydraulic Oil/Clean Hydraulic Oil Tank .....	7-33
Change Transmission Oil .....	7-26
Changing Forward/Reverse Drive Direction.....	4-5
Changing Travel Speed .....	4-5
Check Accelerator Pedal Operation, and Exhaust Gas Color and Noise .....	7-83
Check After Starting .....	3-5
Check Air Conditioner Condenser.....	7-78
Check Air Conditioner Drive Belt.....	7-78
Check Air Conditioner for Damage.....	7-75
Check Air Conditioner Unit.....	7-77
Check and Adjust Tire Pressure .....	7-70
Check and Adjust Valve Clearance.....	7-85
Check and Clean Starter and Alternator .....	7-86
Check and Replace Seat Belt.....	7-81
Check Before Starting .....	3-1
Check Brake Disc (Service and Parking) .....	7-69
Check Brake Oil Level.....	7-67
Check Bucket Bolt-On Cutting Edge for Tightness and/or Wear .....	7-80
Check Canopy/Cab for Damage and Mounting Bolts for Tightness .....	7-81
Check Compressor and Pulley .....	7-79
Check Coolant Level.....	7-53
Check Electrical Harnesses and Fuses.....	7-59
Check Electrolyte Level .....	7-65
Check Electrolyte Specific Gravity.....	7-66
Check Engine Compression Pressure.....	7-86
Check Engine Oil Level .....	7-22
Check Fan Belt .....	7-54
Check Fan Belt Tension.....	7-54
Check Fuel Hoses.....	7-49
Check Fuel Injection Timing .....	7-85
Check Fuel Level .....	7-43
Check Heater Piping.....	7-75
Check Horn, Backup Alarm and Backup Light .....	7-58
Check Hoses and Lines .....	7-40
Check Hydraulic Oil Level.....	7-32
Check Monitor Function and All Other Instrument Operation.....	7-57
Check Outside and Inside Rearview Mirrors.....	7-84
Check Parking Brake Force.....	7-69
Check Pipelines .....	7-77
Check Play in Steering Wheel Stroke.....	7-82
Check Refrigerant Quantity .....	7-79
Check Right and Left Brake Interlocking Performance...	7-68
Check Sound Absorbing Mat Around Engine.....	7-85
Check Steps and Handrails for Damage and Tightness.....	7-84
Check Surrounding Areas Around Axles and Covers for Oil Leaks.....	7-30
Check Switch Operation .....	7-79
Check the Hour Meter Regularly.....	7-2
Check Tire for Damage .....	7-71
Check Wheel Bolt Torque.....	7-71
Check Windshield Washer Fluid Level (Cab Equipped Unit) .....	7-81
Check Work Lights.....	7-58
Checking Hours until Next Maintenance.....	1-18
Clean and Replace Air Cleaner Element.....	7-50
Clean and Replace Circulation Air Filter for Air Conditioner .....	7-76
Clean Axle Housing Air Breather.....	7-30
Clean Engine Compartment and Hood.....	7-84
Clean Radiator, Oil Cooler and Inter Cooler Core.....	7-56
Clean Suction Filter.....	7-35

## INDEX

Clean the Water Separator .....	7-48	Front Work Light Switch (Cab) .....	1-25
Clean Transmission Air Breather .....	7-29	Fuel Gauge .....	1-16
Clearance Light Indicator (Green) .....	1-12	Fuel Level Indicator (Orange) .....	1-11
Clock.....	1-16	Fuel System.....	7-43
Coat Hook .....	1-45	Fuse Box.....	1-40, 1-41, 7-60
Components Name .....	1-1, 1-35	Fuse Box (Cab-Equipped Machines) (Optional).....	1-41, 7-60
Control Panel.....	1-53, 1-59	<b>G</b>	
Control Panel Arrangement.....	1-35	GETTING ON/OFF THE MACHINE .....	1-3
Control Panel Switch Designation and Function.....	1-36	General Precautions for the Cab .....	S-5
Coolant Temperature Gauge.....	1-16	Getting ON/OFF the Machine .....	1-3
Cooling System .....	7-51	Grading .....	5-8
Correct Maintenance and Inspection Procedures.....	7-1	Greasing.....	7-18
<b>D</b>		<b>H</b>	
DRIVING THE MACHINE .....	4-1	Handle Chemical Products Safely.....	S-36
Dig with Caution.....	S-18	Handle Fluids Safely—Avoid Fires.....	S-24
Digging and Loading Level Ground .....	5-7	Handle Starting Aids Safely .....	S-8
Discharge Warning Indicator (Red).....	1-9	Handling Quick Coupler (Mechanical Type) .....	13-1
Dispose of Waste Properly.....	S-36	Hazard Switch (Optional).....	1-24
Door Lock Disengage Lever.....	1-49	Horn Switch .....	1-22
Door Lock Knob .....	1-48	Hour Meter.....	1-16
Door Open/Close Lever .....	1-48	Hydraulic System .....	7-31
Dozing .....	5-11	<b>I</b>	
Drain Water and Sediment from Fuel Tank.....	7-44	Inspect Machine .....	S-4
Drain Water Separator .....	7-45	Inspection and Maintenance of Hydraulic Equipment...	7-31
Drink Holder.....	1-44	Investigate Job Site Beforehand .....	S-10
Drive Machine Safely (Work Site).....	S-13	<b>J</b>	
Drive on Snow Safely .....	S-14	Jump Starting .....	S-9
Drive Safely .....	S-12	<b>K</b>	
Drive Safely with Bucket Loaded .....	S-14	Keep Riders Off Machine .....	S-12
Driving Machine .....	4-1	Key Switch.....	1-33
<b>E</b>		Kind of Oils.....	7-15
Electrical System.....	7-57	<b>L</b>	
Emergency Evacuation Hammer .....	1-45	Layout.....	7-3
Emergency Occasions.....	4-13	LCD Display.....	1-54
Engine.....	7-22	Lever Locks .....	1-32, 5-2
Engine Error Alarm (Red) .....	1-9	Lifting Machine .....	6-10
Engine Hood .....	1-51, 7-7	Lifting Wheel Loader .....	5-12
Engine Oil Pressure Indicator (Red) .....	1-10	Light Switch.....	1-23
Engine Tachometer.....	1-16	List of Consumable Parts .....	7-17
Ensure Safety Before Rising from or Leaving Operator's		Loader Control Lever.....	1-31, 5-1
Seat .....	S-7	Loading .....	5-9
Ensure Safety When Operating on Road Shoulders .....	5-4	Loading/Unloading on Trailer .....	6-1
Equipment of Head Guard, ROPS, FOPS.....	S-11	Lock Frames.....	7-6
Evacuating in Case of Fire.....	S-32	<b>M</b>	
Excavation.....	5-6	MACHINE NUMBERS .....	1
<b>F</b>		MAINTENANCE .....	7-1
Fasten Your Seat Belt .....	S-7	MAINTENANCE UNDER SPECIAL ENVIRONMENTAL	
Features .....	1-4	CONDITIONS .....	9-1
FM/AM Radio Operation .....	1-59	Maintenance .....	1-18
F-N-R Indicator .....	1-15	Maintenance Guide .....	7-9
Follow Safety Instructions.....	S-2	Maintenance Guide Table.....	7-4
For Rapid Cooling:.....	1-37	Maintenance Light (Yellow).....	1-13
Forward/Reverse Lever.....	1-21		
Front Console.....	1-5		
Front Window Wiper Switch (Cab).....	1-28		

## INDEX

Maintenance of the Air Conditioner Being Not in Use.....	1-37
Maintenance Under Special Environmental Conditions.....	9-1
Miscellaneous.....	7-80
Monitor Display.....	1-14
Monitor Panel.....	1-7
Mono-Lever Type.....	1-31
Move and Operate Machine Safely.....	S-8
<b>N</b>	
Name of Components.....	1-38
Neutral Lever Lock (Forward/Reverse Lever).....	1-21
Never Ride Attachment.....	S-6
Never Undercut a High Bank.....	S-18
<b>O</b>	
OPERATING THE ENGINE.....	3-1
OPERATING THE MACHINE.....	5-1
OPERATOR'S STATION.....	1-4
OPTIONAL ATTACHMENTS.....	13-1
Object Handling.....	S-20
Observe Engine Operation Closely.....	2-1
Oil Separator Element (Blow-by Gases).....	7-25
Opening/Closing Engine Hood.....	1-51
Operate Only from Operator's Seat.....	S-9
Overheat Indicator (Red).....	1-10
<b>P</b>	
Park Machine Safely.....	S-22
Parking Brake Indicator (Red).....	1-9
Parking Brake Switch.....	1-27, 4-4
Perform Truck Loading Safely.....	S-18
Periodic Replacement of Parts.....	7-8
Power Train.....	7-26
Practice Safe Maintenance.....	S-25
Precautions for After Operation.....	5-13
Precautions for Driving on Slopes.....	4-9
Precautions for Handling Accumulator and Gas Damper.....	S-33
Precautions for Lightning.....	S-19
Precautions for Maintenance During Cold Weather Season.....	9-2
Precautions for Operation.....	S-19, 5-4
Precautions for Welding and Grinding.....	S-32
Precautions to Be Taken if the Machine Failure Occurs.....	4-10
Preheat Indicator (Yellow).....	1-11
Preparations for Inspection and Maintenance.....	7-5
Prepare for Emergencies.....	S-3
Prevent Battery Explosions.....	S-35
Prevent Burns.....	S-28
Prevent Fires.....	S-30
Prevent Parts from Flying.....	S-28
Protect Against Flying Debris and Falling Object.....	S-21
Protect Against Noise.....	S-4
Provide Signals for Jobs Involving Multiple Machines.....	S-11
<b>R</b>	
Radio Unit (CAB) (Optional).....	1-53
Rear Window Wiper Switch (Cab).....	1-28
Rear Work Light Switch (Cab, Optional).....	1-26
Rearview Mirror.....	1-45
Recognize Safety Information.....	S-1
Removal and Installation of Tire.....	7-74
Remove Paint Before Welding or Heating.....	S-34
Removing Snow.....	5-12
Removing the Machine from Storage.....	10-2
Replace Engine Oil Filter.....	7-24
Replace HST Oil Filter Element.....	7-36
Replace Main Fuel Filter Element.....	7-47
Replace Return Filter.....	7-38
Replace Rubber Hoses Periodically.....	S-29
Resetting Hours until Next Maintenance.....	1-19
Retighten Front Axle and Rear Axle Support Mounting Bolts.....	7-86
Right Console.....	1-6, 1-30
Room Light.....	1-44
Rops Cab (Optional).....	1-42
<b>S</b>	
SAFETY.....	S-1
SAFETY SIGNS.....	S-37
SPECIFICATIONS.....	12-1
STORAGE.....	10-1
Scooping.....	5-11
Seat Back Pocket.....	1-39
Seat Belt Indicator (Red).....	1-11
Service Air Conditioning System Safely.....	S-35
Service Indicator (Yellow).....	1-8
Setting Screens.....	1-70
Starting Engine.....	3-3
Starting to Move.....	4-2
Stay Clear of Moving Parts.....	S-27
Steering.....	1-22, 4-6
Steps.....	1-51
Stop and Restart of Travel.....	4-7
Stop/Parking.....	4-11
Stopping Engine.....	3-10
Store Attachments Safely.....	S-22
Storing the Machine.....	10-1
Sun Visor.....	1-44
Support Machine Properly.....	S-26
Support Maintenance Properly.....	S-27
Switches, Steering Wheel and Pedals.....	1-20
<b>T</b>	
TRANSPORTING.....	6-1
TROUBLESHOOTING.....	11-1
Tightening and Retightening Torque of Nuts and Bolts.....	7-87
Time.....	1-17
Tips for Optimal Air Conditioner Usage.....	1-37
Tire.....	7-70
Tire Wheel.....	7-74

## INDEX

---

Towing Method.....	6-9
Towing Pin .....	1-50
Transport Safely .....	S-23
Transporting.....	6-3
Transporting by Road .....	6-1
Transporting by Trailer .....	6-1
Transporting Wheel Loader (Urgent Situation) .....	6-4
Travel Mode Indicator (Optional).....	1-15
Travel Mode Switch .....	1-34
Travel on Public Roads Safely.....	S-15
Turn Signal Indicator (Green) .....	1-12
Turn Signal Lever .....	1-22
<b>U</b>	
Understand Signal Words.....	S-1
USB Device Input.....	1-67
Use Correct Fuels and Lubricants .....	7-2
Use Handrails and Steps .....	S-6
Using Booster Batteries.....	3-6
<b>V</b>	
Vandal-Resistant Devices.....	1-52
<b>W</b>	
Warm Up Operation .....	3-8
Warm Up Operation in Cold Weather .....	3-9
Warn Others of Service Work .....	S-26
Wear Protective Clothing.....	S-3
When Fully Opening the Door.....	1-49
When Windows Become Clouded:.....	1-37
Window Open/Close Levers .....	1-48
Work Light Indicator (Yellow).....	1-12